

Metalgerätehaus

Lübeck 3.66 m²

Montageanleitung

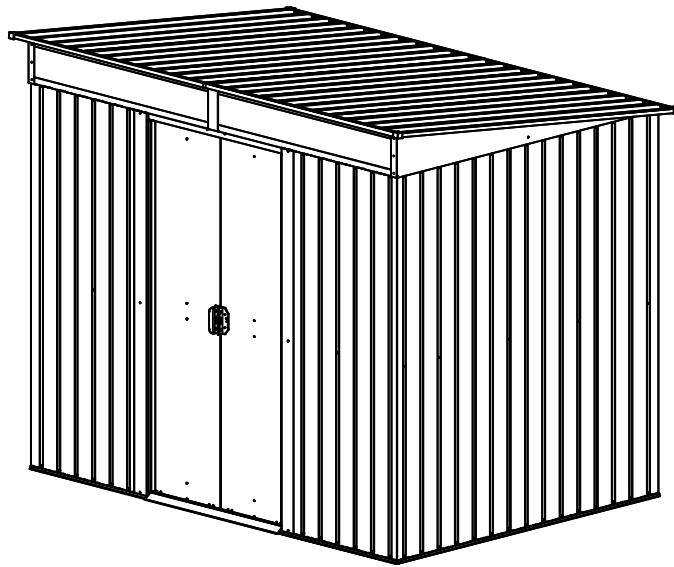

SD-PS68-H170

Erfordert zwei Personen und dauert 1–2 Stunden für die Montage.

Schneller und einfacher Aufbau

Wände mit verstärktem Dachfirst

In verschiedenen Größen erhältlich

BEVOR SIE BEGINNEN

Benutzerhandbuch

Vor der Montage ist es wichtig, dass Sie Ihre örtliche Baubehörde kontaktieren, um festzustellen, ob eine Baugenehmigung erforderlich ist. Lesen und verstehen Sie dieses Benutzerhandbuch sorgfältig. Wichtige Hinweise und hilfreiche Tipps erleichtern Ihnen den Aufbau und machen ihn angenehmer.

Montageanleitung

Die Anleitungen in diesem Handbuch enthalten alle relevanten Informationen für Ihr Modell. Lesen Sie alle Anweisungen gründlich durch, bevor Sie beginnen. Befolgen Sie während der Montage die einzelnen Schritte genau, um ein korrektes Ergebnis zu erzielen.

Teile

Überprüfen Sie, ob alle notwendigen Teile für den Aufbau vorhanden sind. Sortieren Sie den Inhalt des Kartons nach Teilenummern und vergleichen Sie diese mit der Teileliste. Machen Sie sich mit dem mitgelieferten Befestigungsmaterial vertraut, um den Aufbau zu erleichtern. Diese befinden sich ebenfalls im Karton. Bitte beachten Sie, dass zur Erleichterung des Aufbaus zusätzliche Befestigungselemente beigelegt wurden.

WERKZEUGE

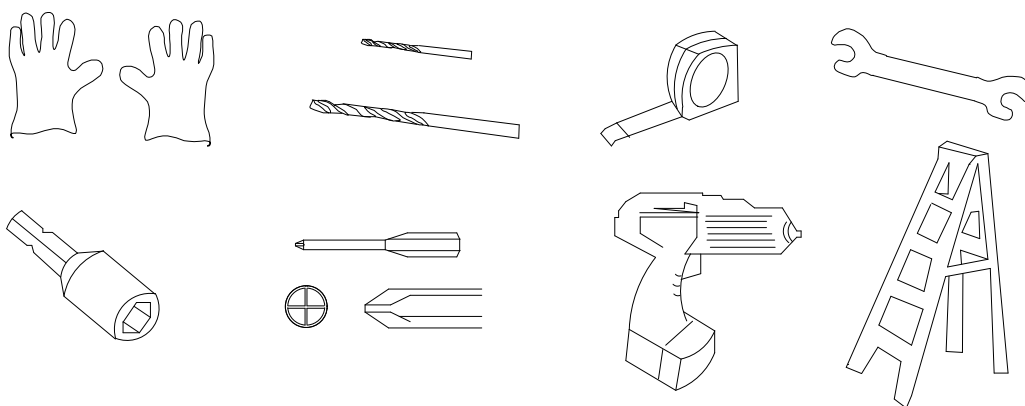

Tragen Sie beim Umgang mit Stahlblechen und Abdeckungen unbedingt **Schutzhandschuhe**.

VORAUSSPLANEN

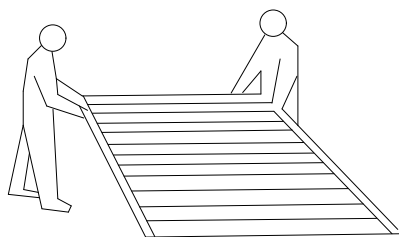

Achten Sie auf das Wetter:

Stellen Sie sicher, dass der gewählte Bautag trocken und windstill ist.

Versuchen Sie **nicht**, das Gerätehaus bei windigem Wetter aufzubauen – es besteht Verletzungsgefahr und das Risiko, dass Paneele beschädigt werden. Achten Sie außerdem auf nassen oder matschigen Untergrund.

Teamarbeit:

Wenn möglich, sollte der Aufbau immer von zwei oder mehr Personen durchgeführt werden. Eine Person kann Teile oder Paneele positionieren, während die andere das Befestigungsmaterial und das Werkzeug handhabt.

VORAUSPLANEN

Auswahl des Aufstellorts

- Vermeiden Sie nach Möglichkeit überhängende Bäume, da herabfallendes Laub eine regelmäßige Reinigung erforderlich macht und abgebrochene Äste eine potenzielle Gefahr darstellen.
- Kleine Bäume, Büsche oder nahegelegene Zäune können hilfreich sein, da sie als Windschutz dienen.

Vorbereitung des Aufstellorts

Der Aufstellort muss so vorbereitet werden, dass der Untergrund rundum eben ist – eine Kontrolle mit einer Wasserwaage ist erforderlich.

Die Basis kann aus behandeltem Holz oder Beton bestehen, um das Eindringen von Feuchtigkeit in das Gerätehaus zu verhindern. Das Gerätehaus ist **nicht** dafür ausgelegt, direkt auf den Rasen aufgebaut zu werden. Außerdem wird der Boden bei Regen schnell matschig.

Wenn ein Betonfundament erstellt wird, ist es wichtig, dass dieses zu den Rändern hin leicht abschüssig ist, um das Eindringen von Wasser zu verhindern.

Vor dem Aufbau des Gerätehauses muss dem Beton oder Zement ausreichend Zeit zum Trocknen gegeben werden.

Fundamente können auch aus Ziegeln oder Betonblöcken gebaut werden oder auf einer Betonplatte basieren.

Die Ziegel oder Blöcke sollten fest auf ebenem Betonfundament zementiert werden. Der Rahmen des Gerätehauses sollte anschließend auf der Basis fest verschraubt werden.

WICHTIGE HINWEISE:

Holen Sie sich Hilfe: Der Aufbau ist deutlich einfacher, wenn eine zweite Person Teile halten oder Werkzeuge anreichen kann. Einige Montageschritte erfordern zudem, dass zwei Personen Bauteile gemeinsam anheben. Die Arbeit ist nicht besonders schwer und für die meisten körperlich fitten Personen geeignet.

















Planen Sie ausreichend Zeit ein: Hektik führt häufig zu Fehlern und dazu, dass Arbeitsschritte wiederholt werden müssen. Wenn Sie noch nie ein Gerätehaus aufgebaut haben, kann der Aufbau gut einen ganzen Tag in Anspruch nehmen..















Haben Sie das richtige Werkzeuge griffbereit

Tragen Sie die empfohlene Schutzkleidung wie im Abschnitt „Werkzeuge“ beschrieben.

Idealerweise sollten Sie alle Teile vor dem Aufbau auslegen und prüfen, ob alles vorhanden ist. Legen Sie die Teile auf Tücher oder Folien, wenn Kratzer vermieden werden sollen.





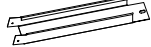

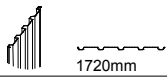
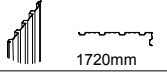
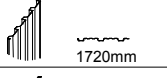
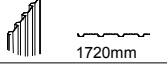
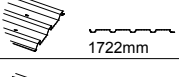
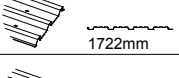
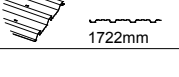
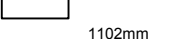

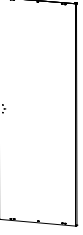
Ziehen Sie alle Muttern sorgfältig fest, achten Sie darauf, keine zu vergessen. Kontrollieren Sie mit einer Wasserwaage, ob das Gestell im Lot und rechtwinklig steht.

NO.	PART	Qty.
1	 1608mm	2
3L	 823mm	1
3R	 823mm	1
4L	 1169mm	1
4R	 1169mm	1
5	 765mm	1
6	 876mm	1
7	 1110mm	1
8	 1110mm	1
9	 1574mm	1
10L	 1131mm	1
10R	 1131mm	1
11	 1574mm	1
11-1	 867mm	1
11-2	 1507mm	1
B1	 97mm	2



NO.	PART	Qty.
15	 1722mm	2
17L	 1195mm	2
17R	 1195mm	2
20	 411mm	6
21L		1
21R		1
25L	 1720mm	1
25R	 1720mm	1
C1	 1315mm	1
C2	 1315mm	1
C3	 1140mm	1
C4	 1140mm	1
C5	 276mm	1
C6	 164mm	1
C7	 245mm	2

NO.	PART	Qty.
P1	 1720mm	9
P2	 1720mm	4
P3	 1720mm	3
P6	 1720mm	2
P4L	 1722mm	2
P4R	 1722mm	2
P5	 1722mm	2
P0	 1102mm	2

NO.	PART	Qty.
D1	 1710X415mm	1
D2	 1710X415mm	1

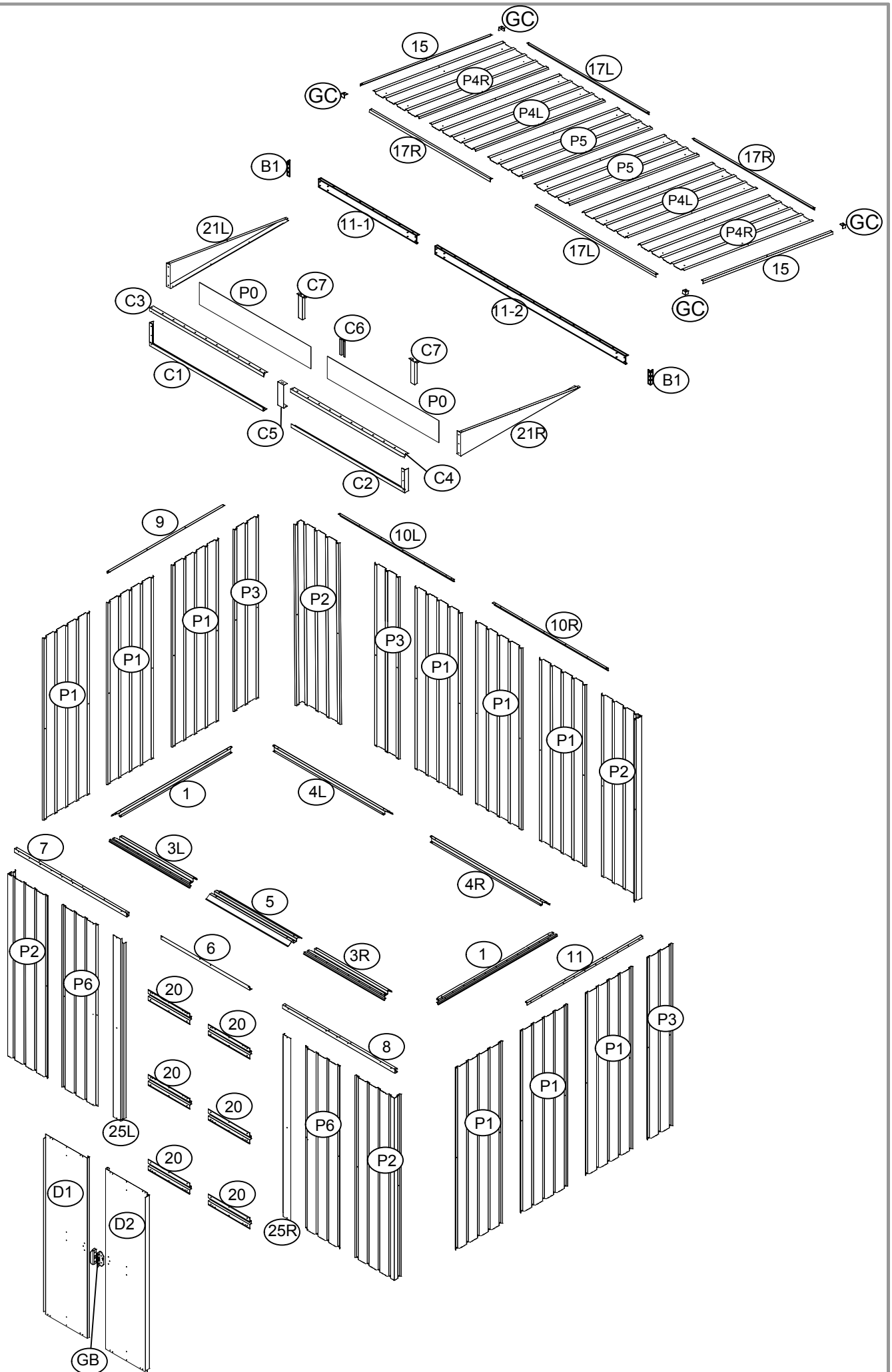
NO.	PART	Qty.
G2	 4	4
GD	 4	4
GB	 2	2
GC	 4	4
F1	 260	260
F2	 50	50
F3	 8	8
S2	 120	120
S3	 240	240



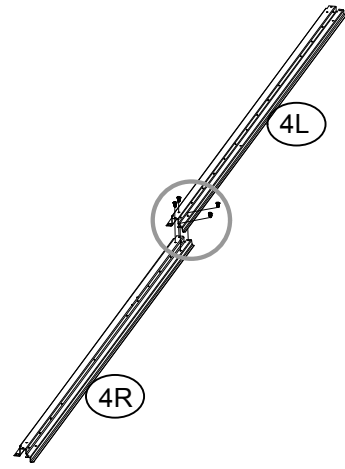
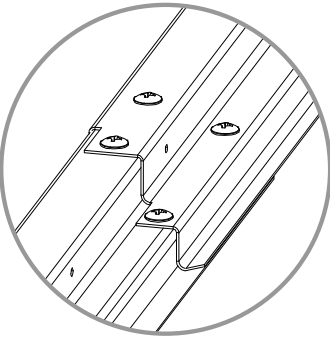
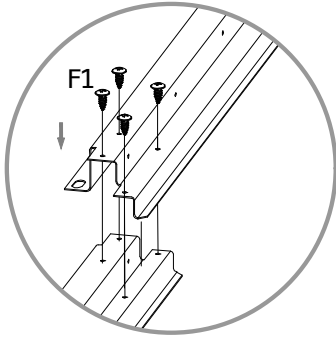

NO.	PART	Qty.
4L		1
4R		1

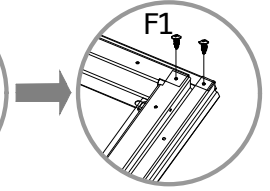
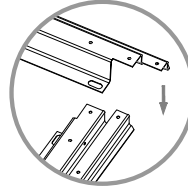
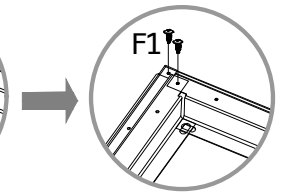
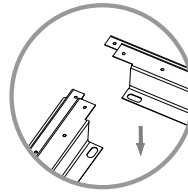
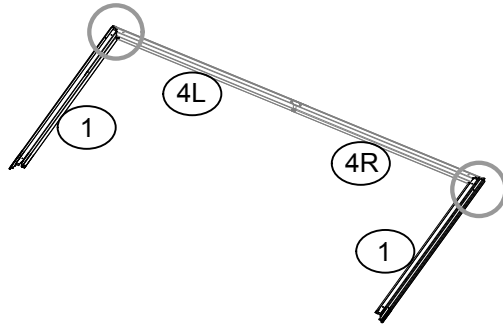

NO.	PART	Qty.
1		2



NO.	PART	Qty.
3L		1
3R		1

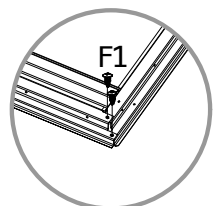
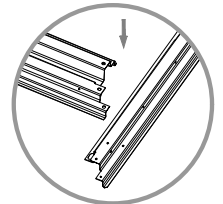
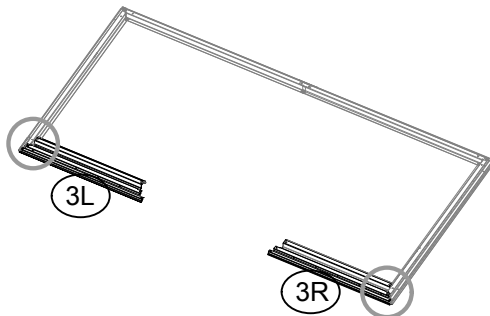
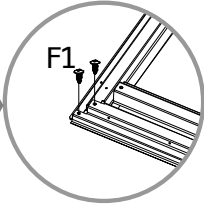
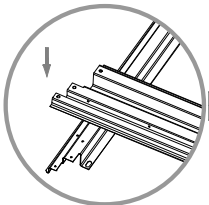

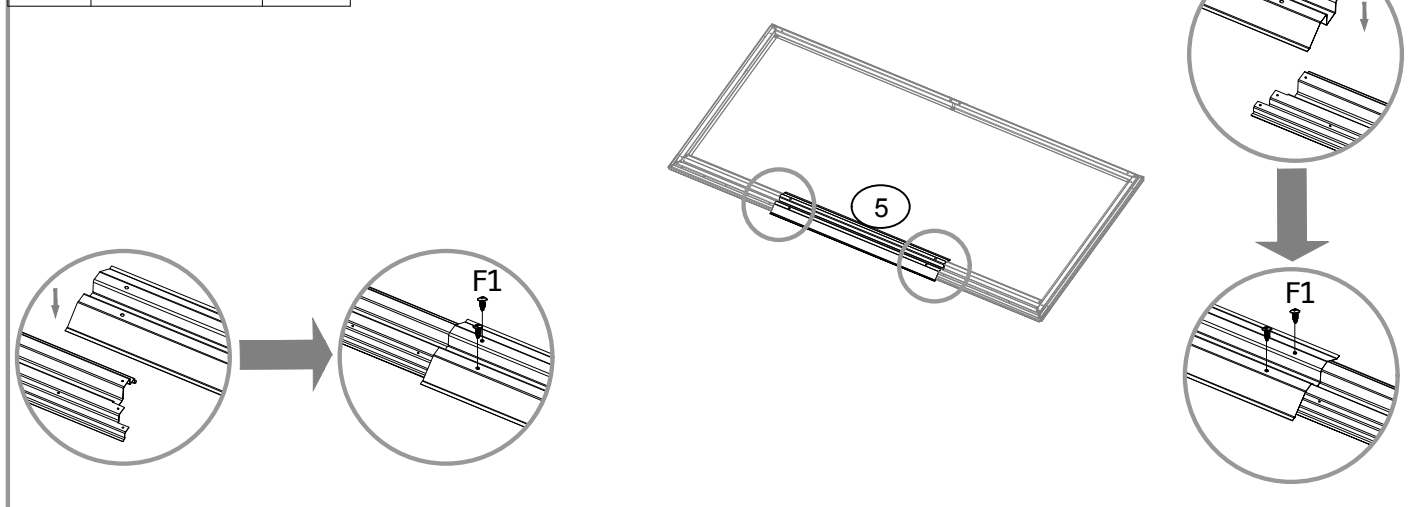

NO.	PART	Qty.
5		1



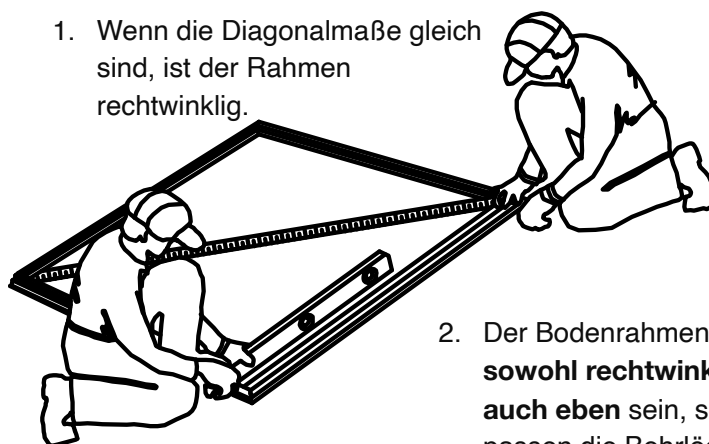

1. Wenn die Diagonalmaße gleich sind, ist der Rahmen rechteckig.



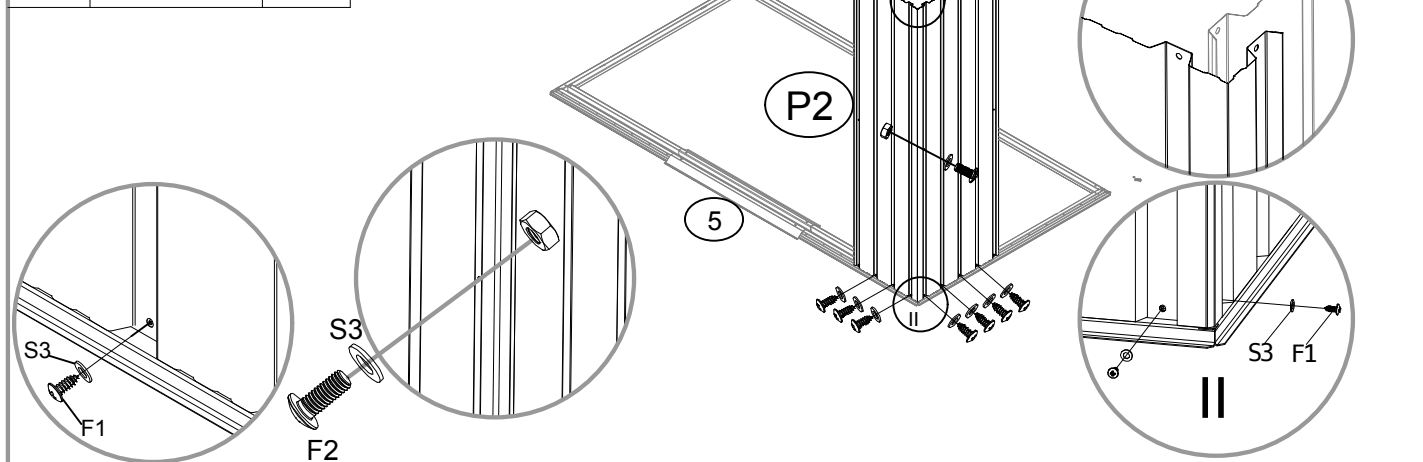

2. Der Bodenrahmen muss sowohl rechteckig als auch eben sein, sonst passen die Bohrlöcher nicht richtig zueinander.

NO.	PART	Qty.
P2		1
P1		1



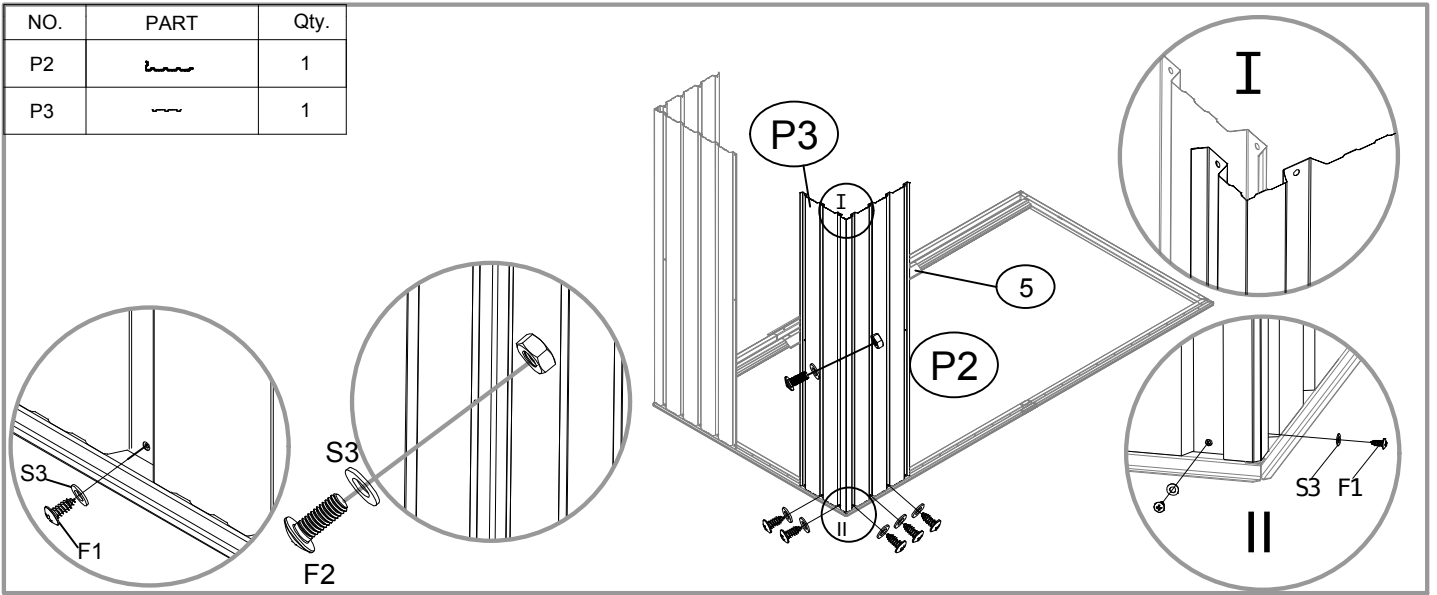

NO.	PART	Qty.
P2		1
P3		1

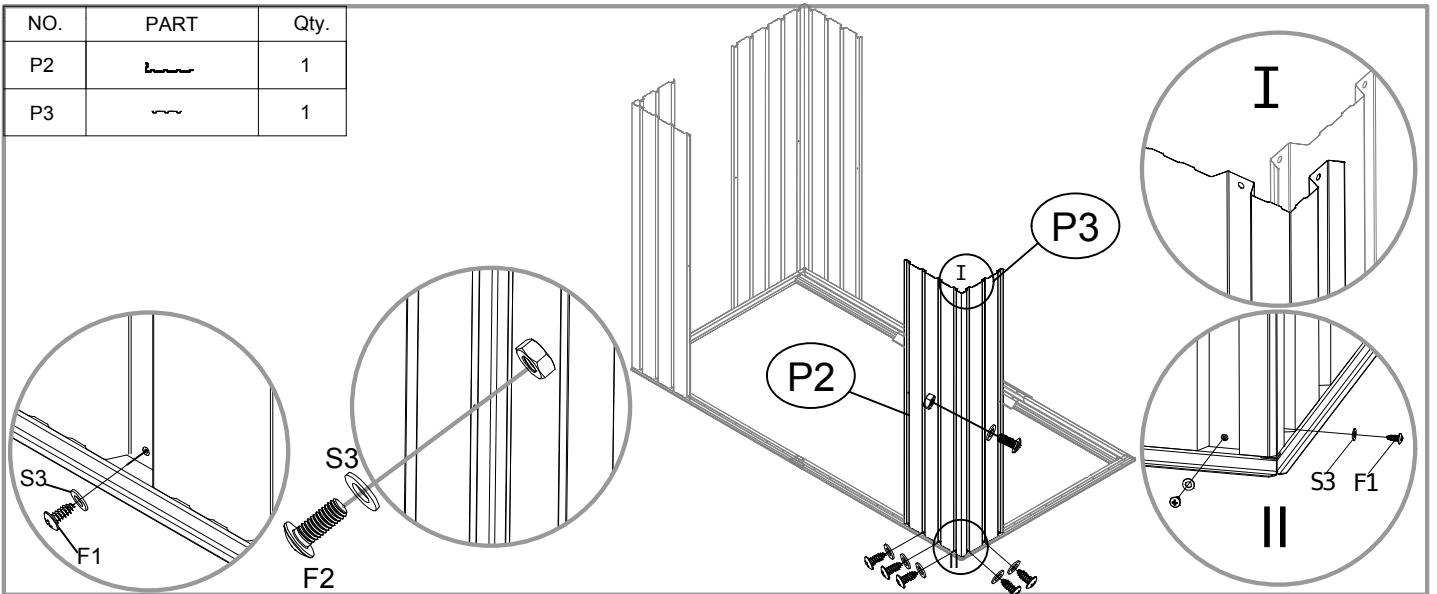

NO.	PART	Qty.
P2		1
P3		1



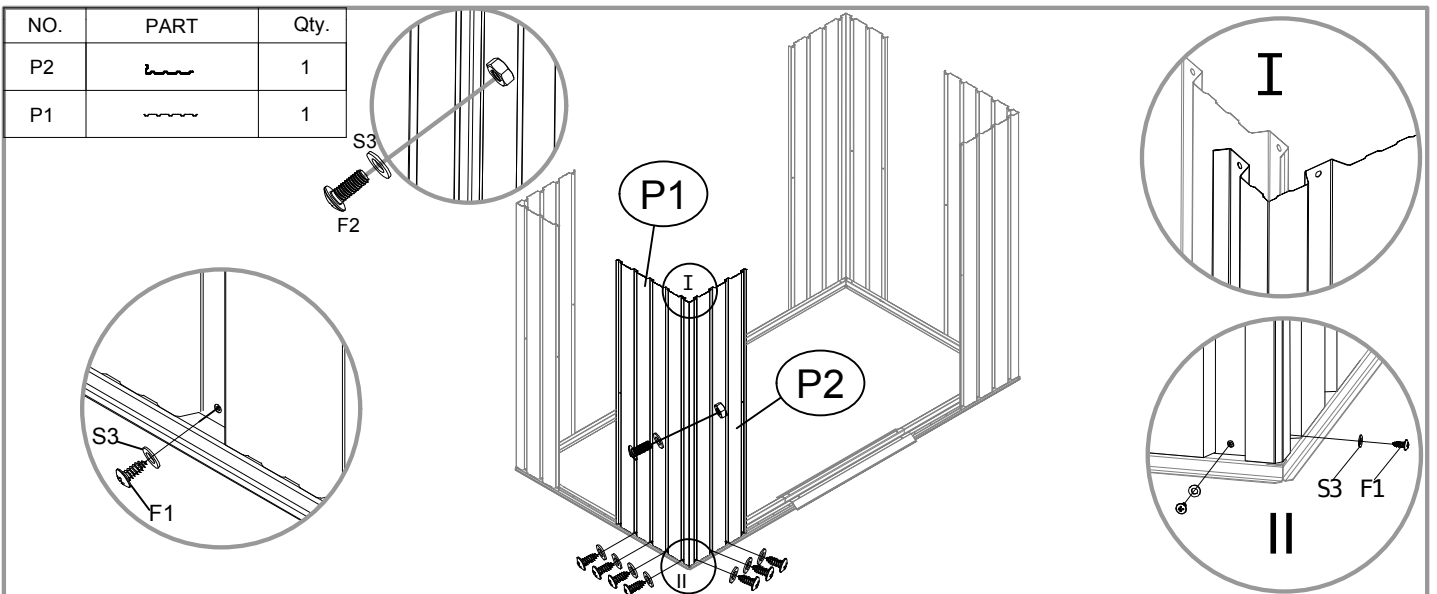

NO.	PART	Qty.
P2		1
P1		1



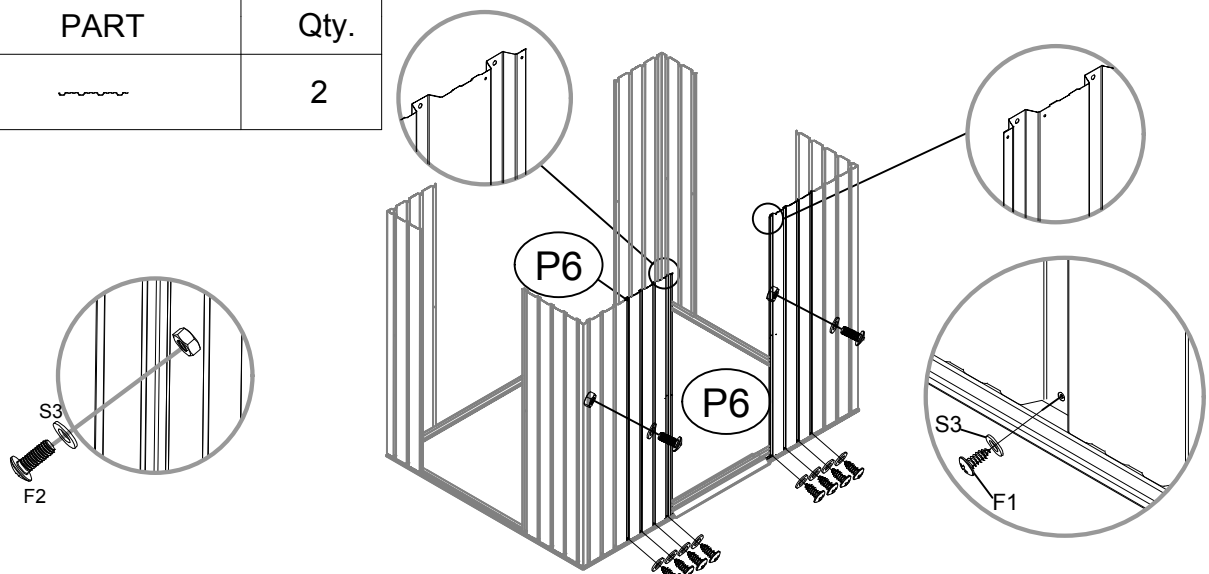

NO.	PART	Qty.
P6		2



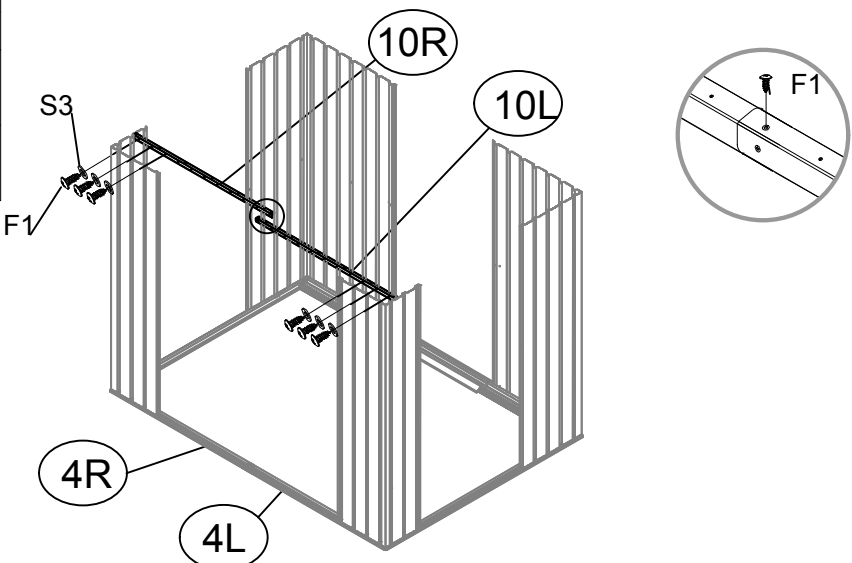

NO.	PART	Qty.
10L		1
10R		1



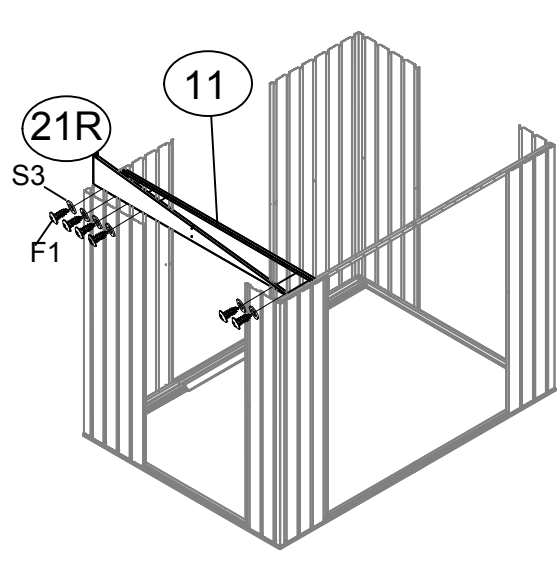



NO.	PART	Qty.
11		1
21R		1

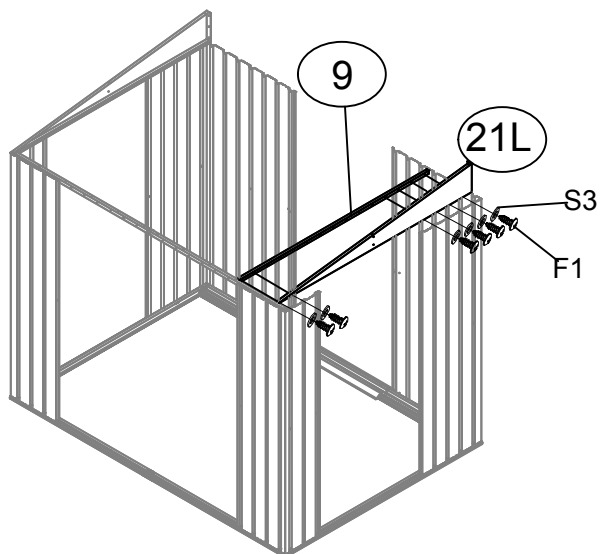

NO.	PART	Qty.
9		1
21L		1



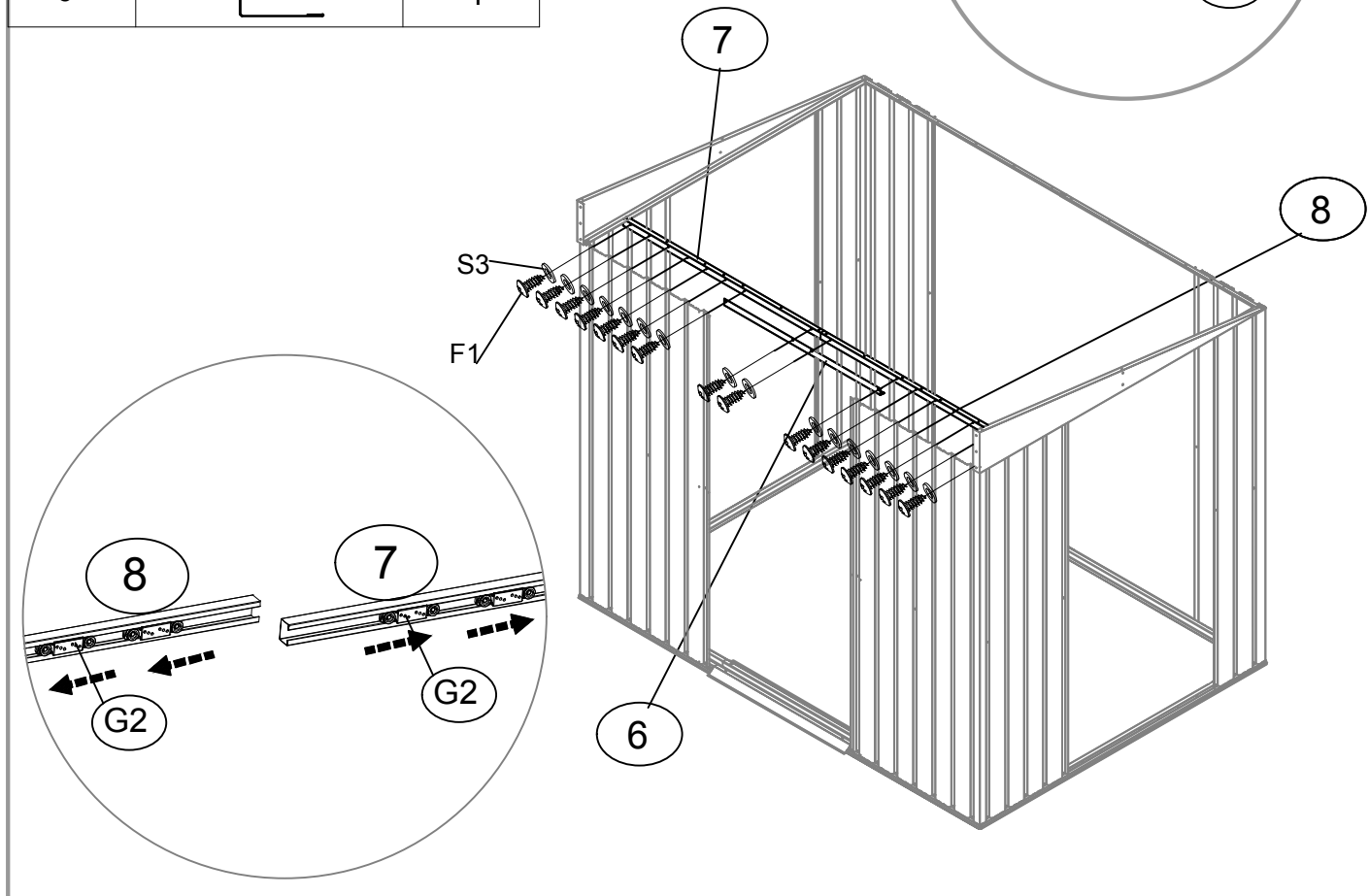
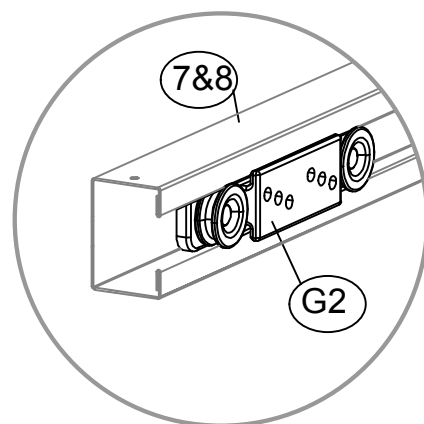

NO.	PART	Qty.
7		1
8		1
G2		4
6		1

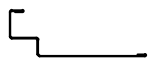
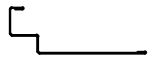

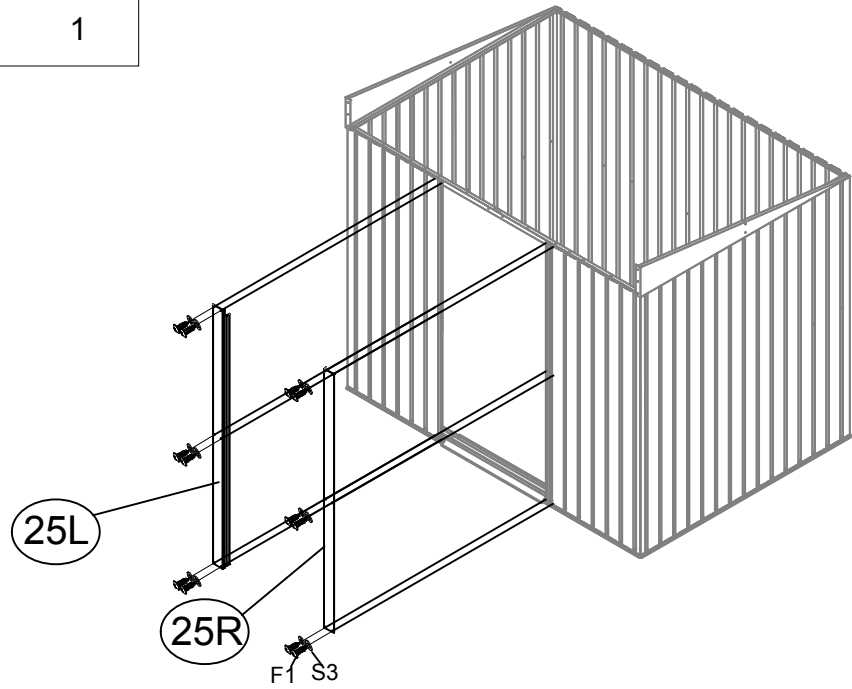

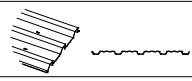
NO.	PART	Qty.
25L		1
25R		1

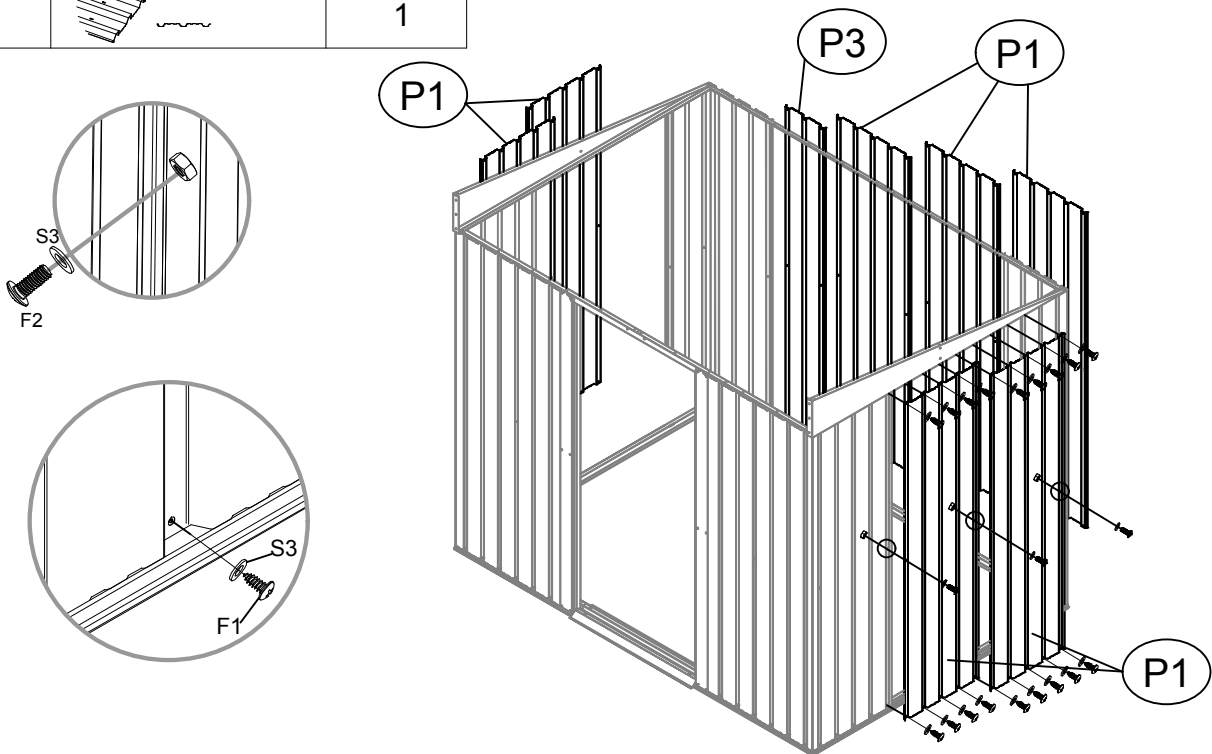

NO.	PART	Qty.
P1		7
P3		1



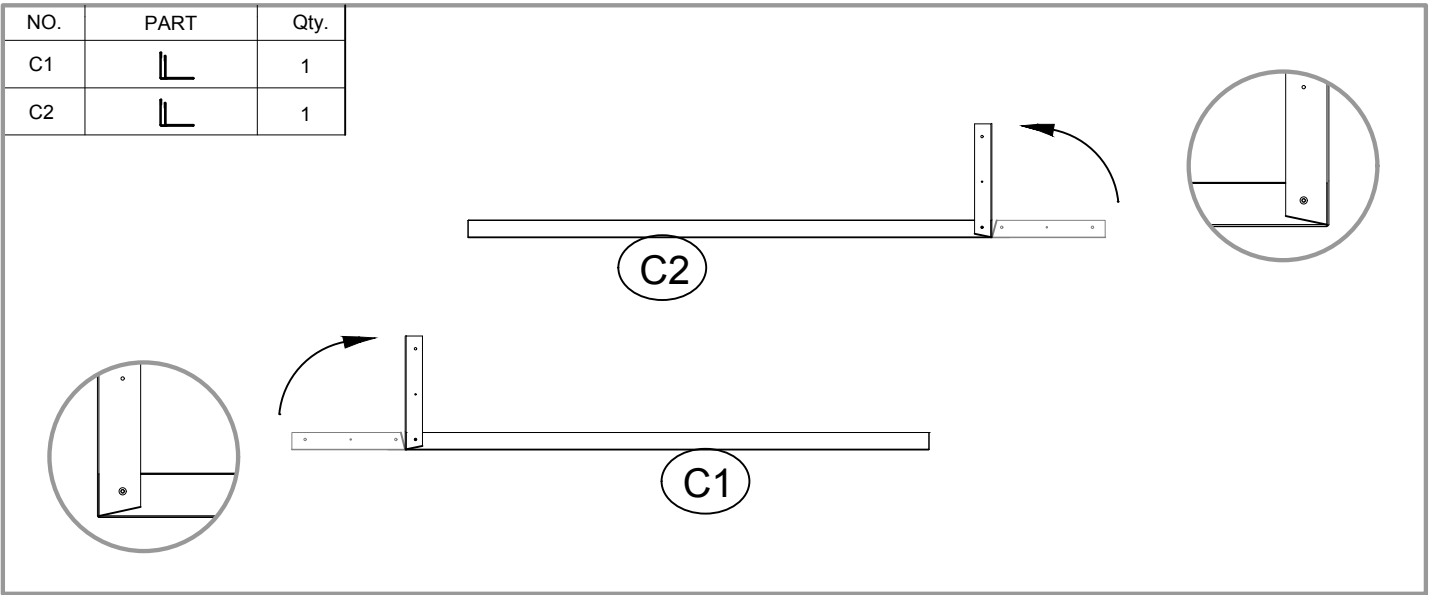

NO.	PART	Qty.
C1		1
C2		1

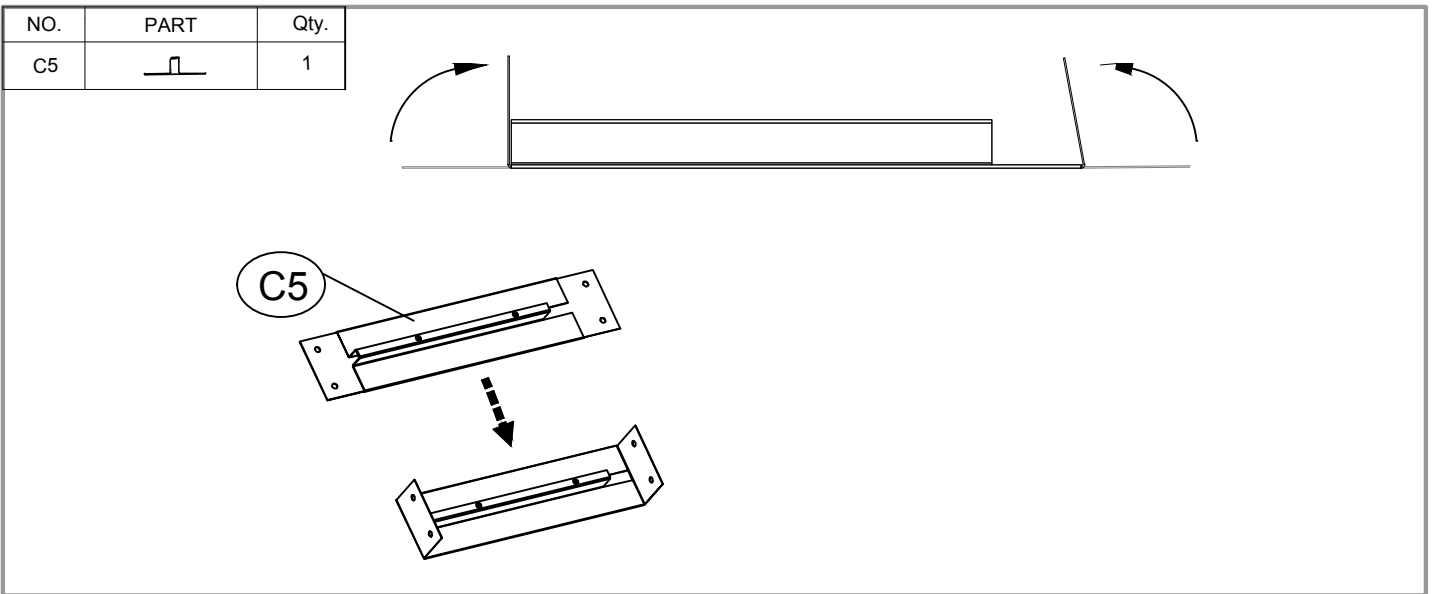

NO.	PART	Qty.
C5		1



NO.	PART	Qty.
C3		1
C4		1

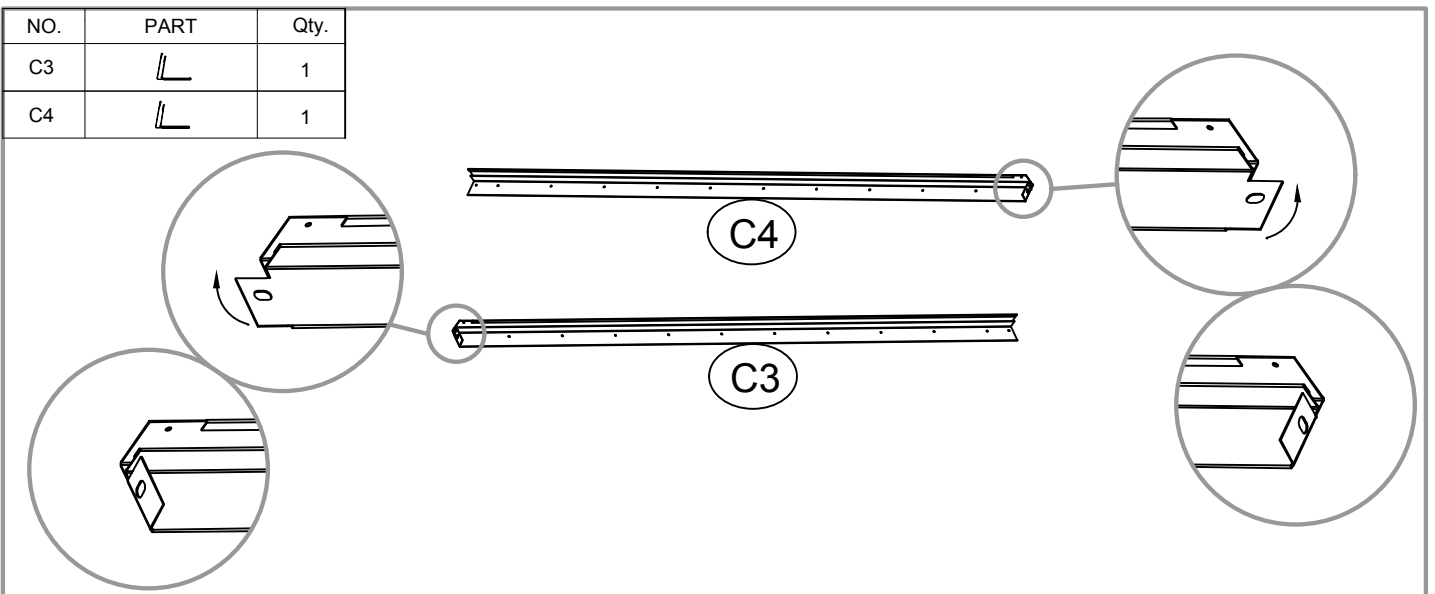

NO.	PART	Qty.
P0		2

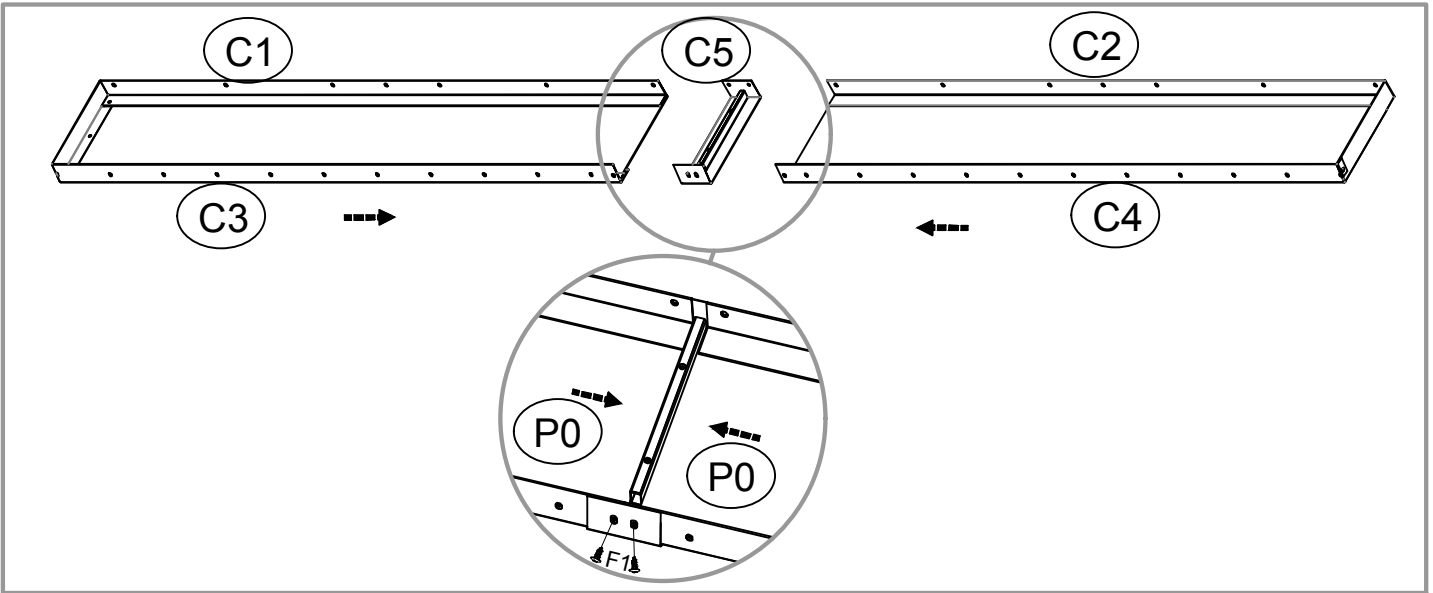
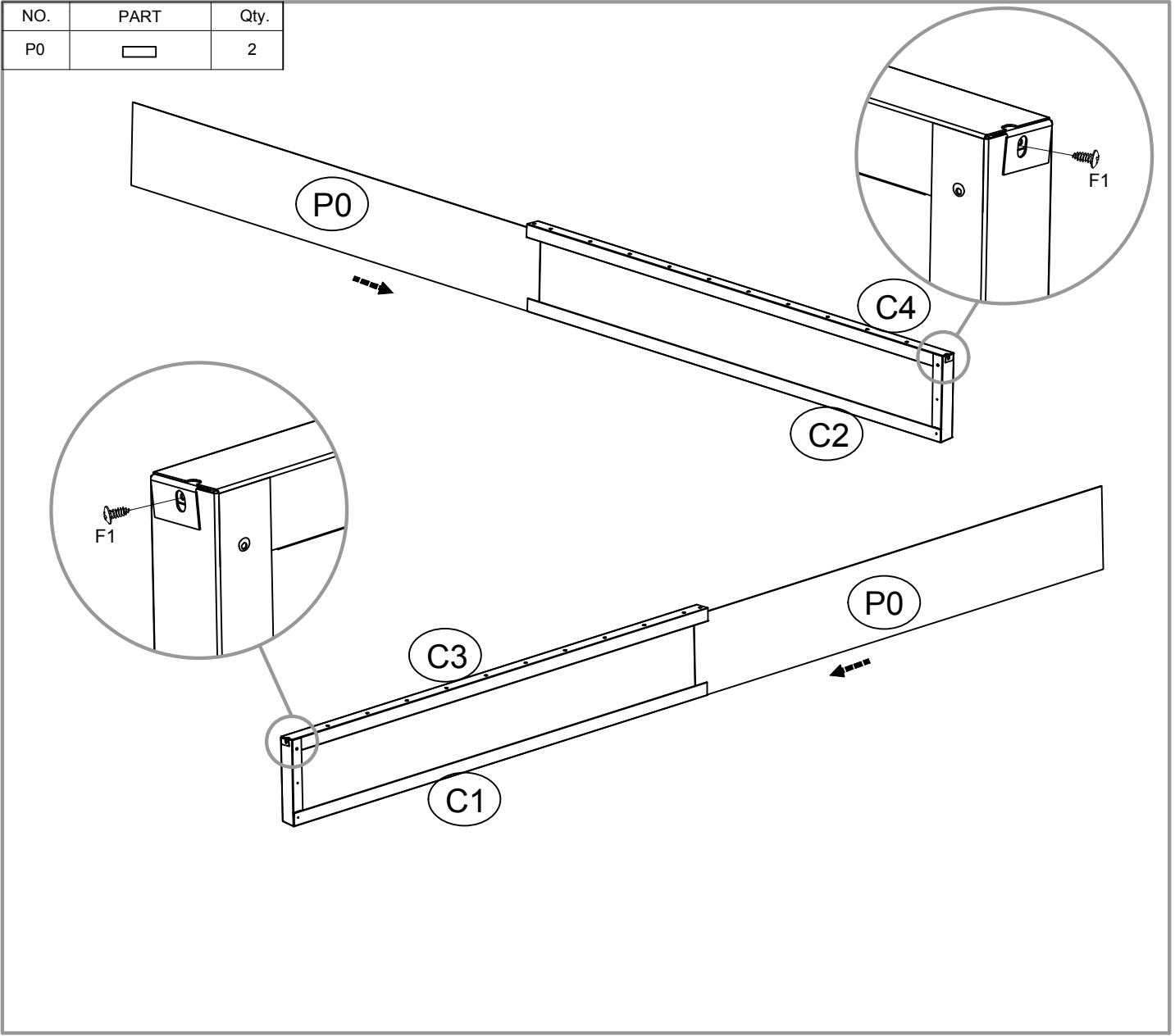

NO.	PART	Qty.
C6		1

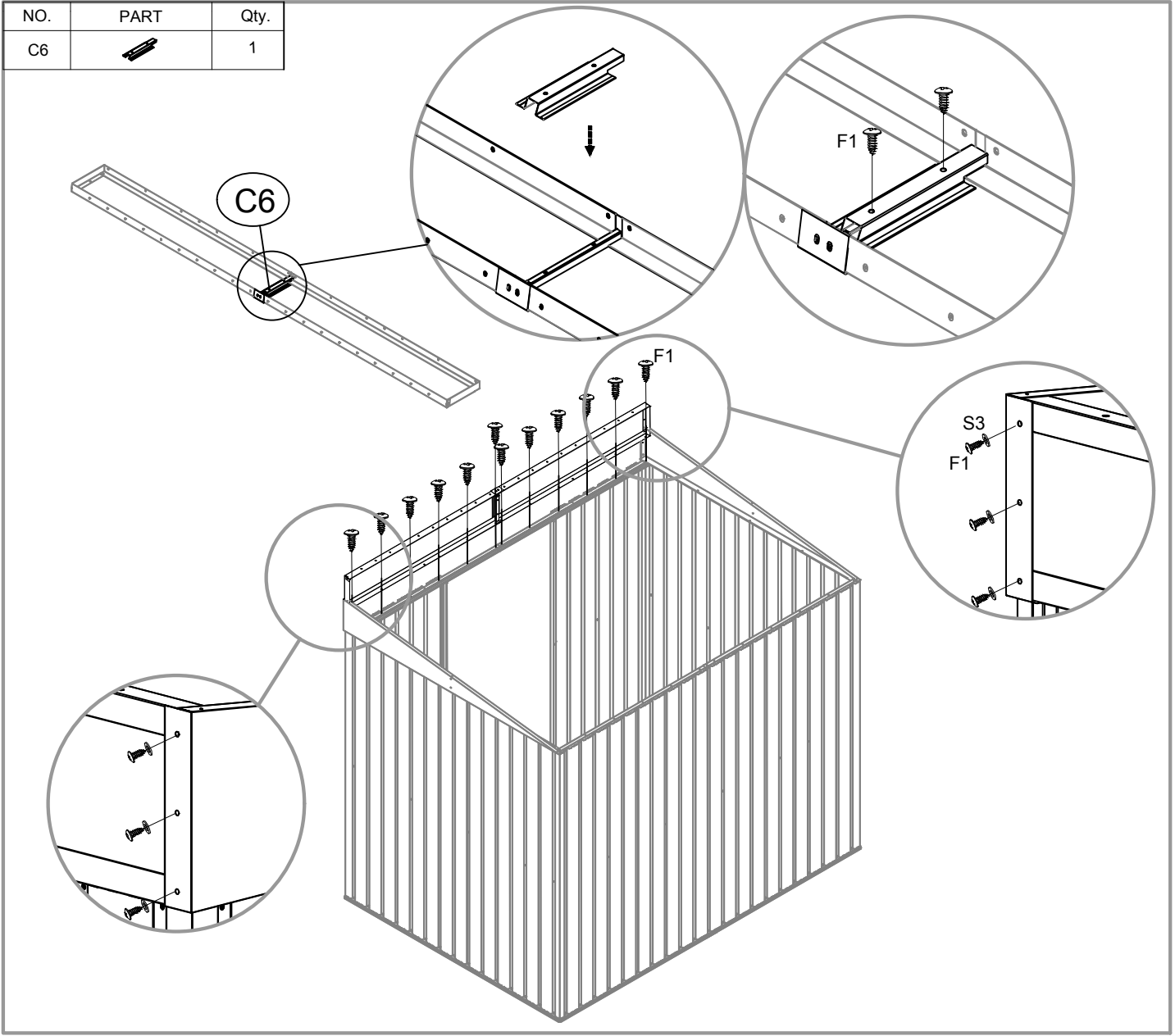

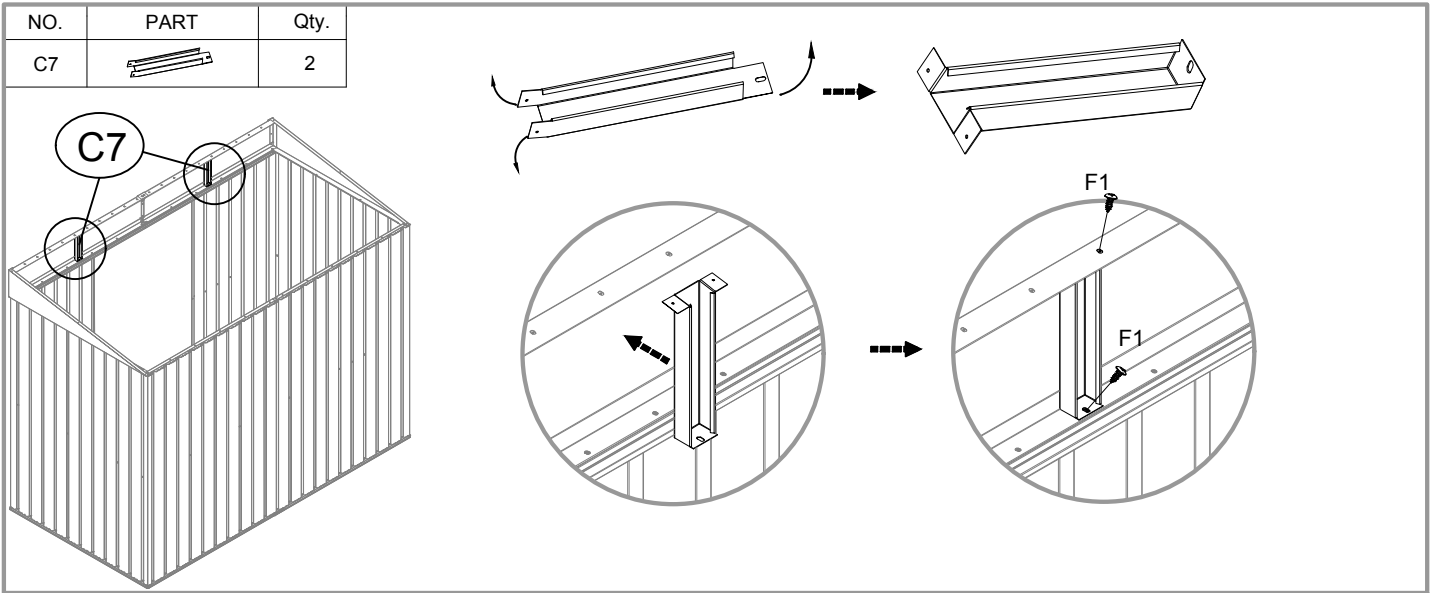

NO.	PART	Qty.
C7		2

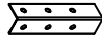

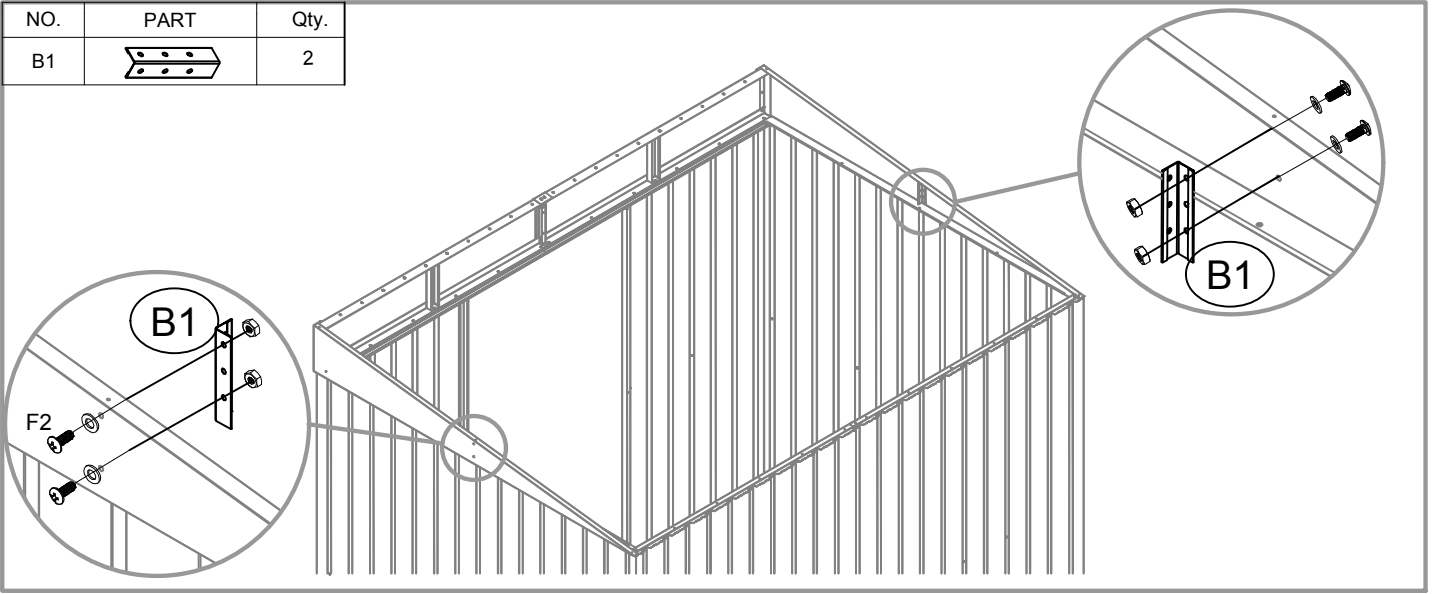

NO.	PART	Qty.
B1		2



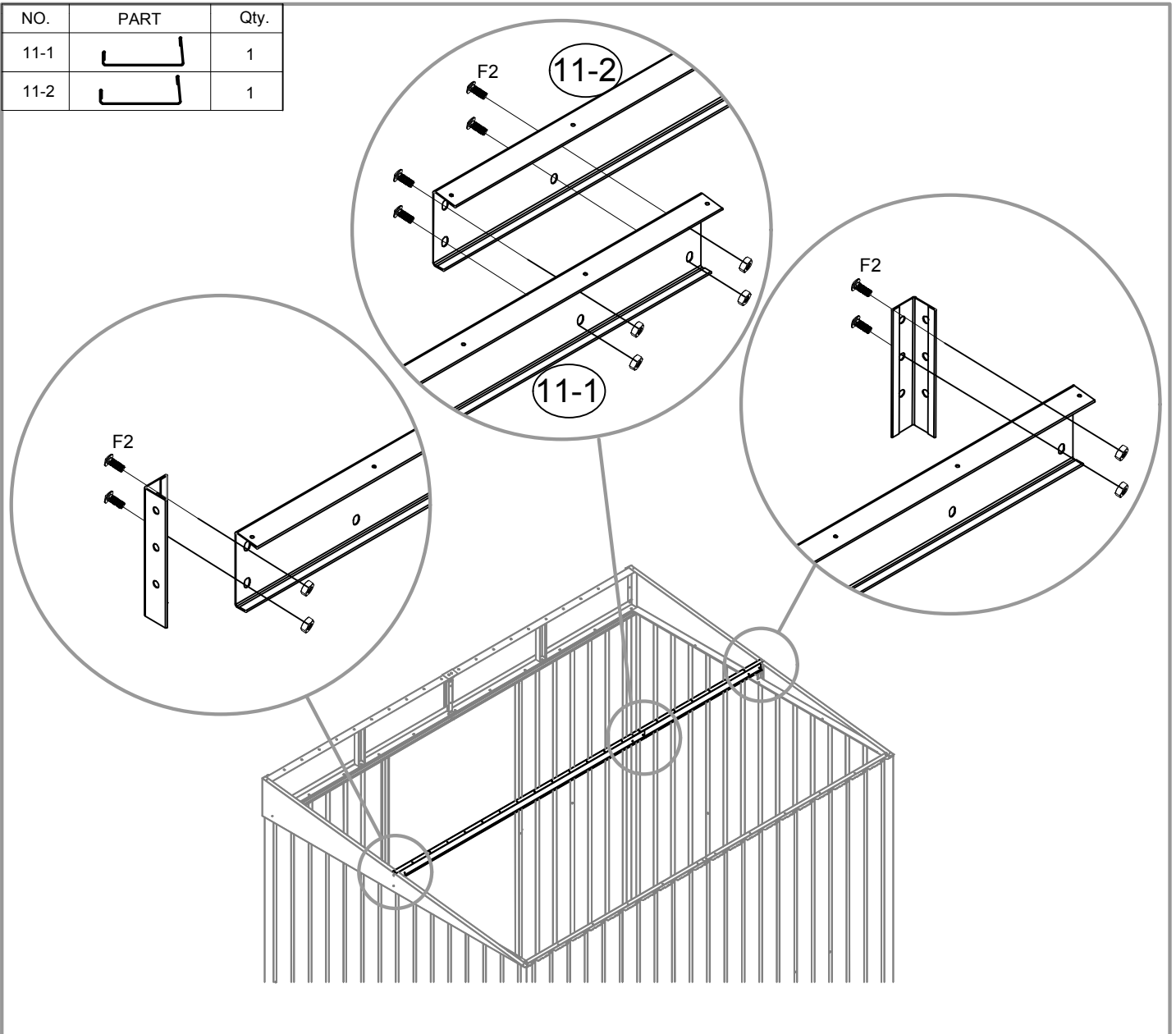



NO.	PART	Qty.
11-1		1
11-2		1

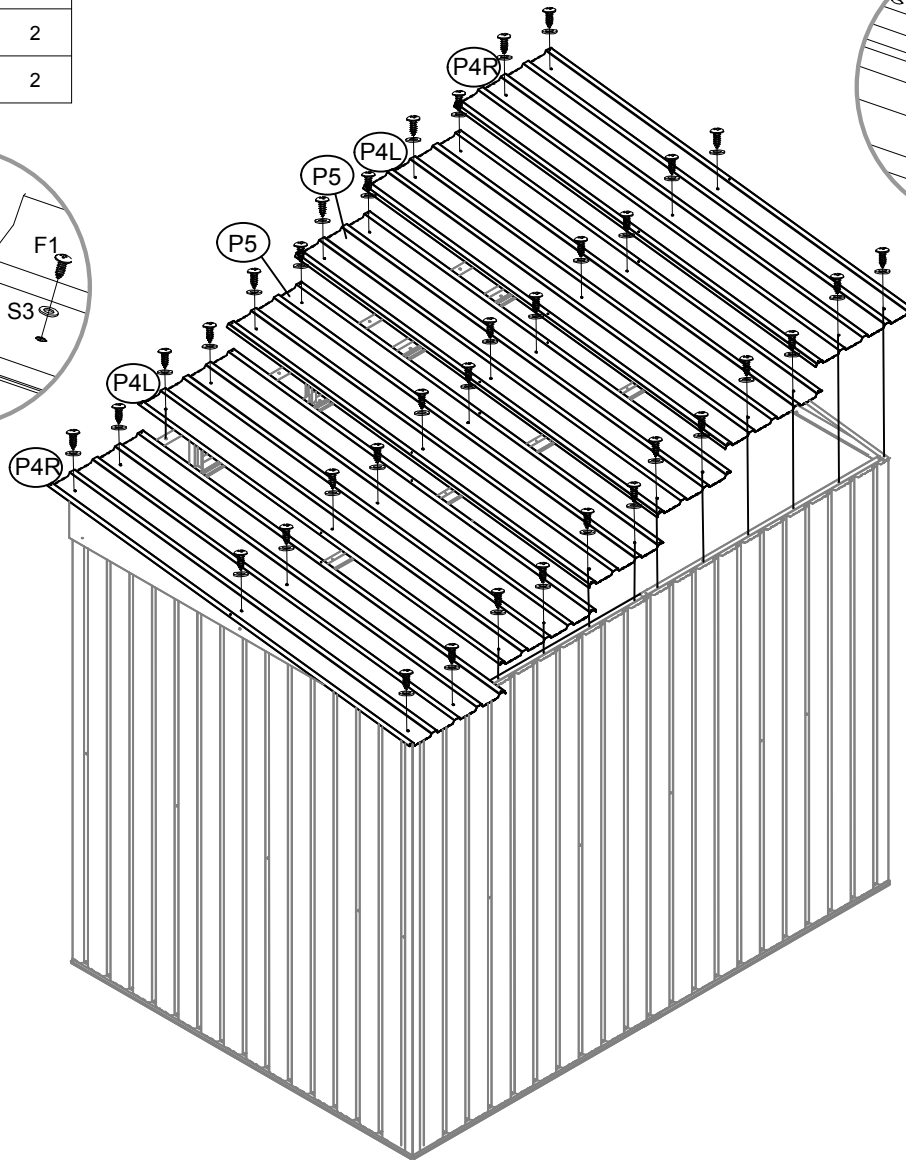
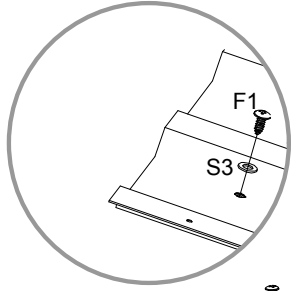

NO.	PART	Qty.
P4L		2
P4R		2
P5		2



NO.	PART	Qty.
15		2
17L		2
17R		2
GC		4

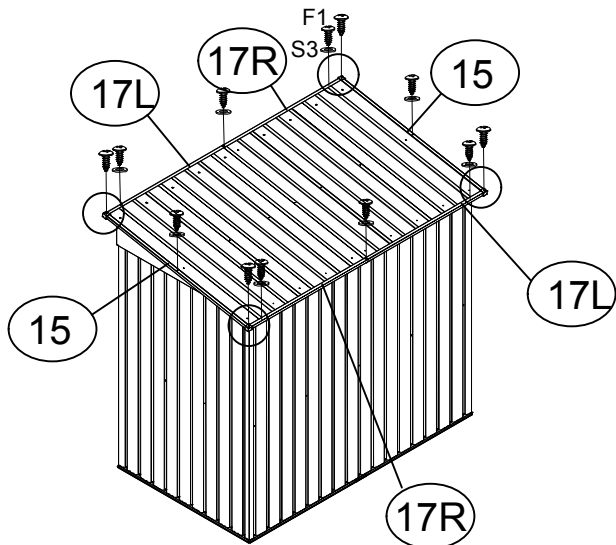
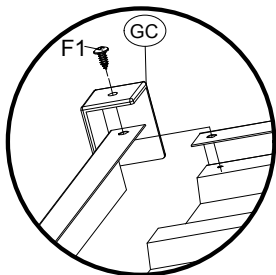

NO.	PART	Qty.
D1		1
D2		1
GB		2

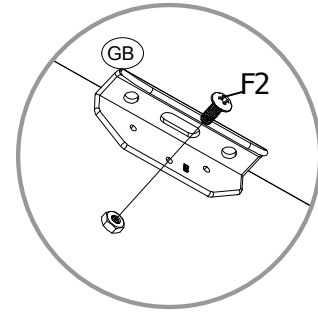
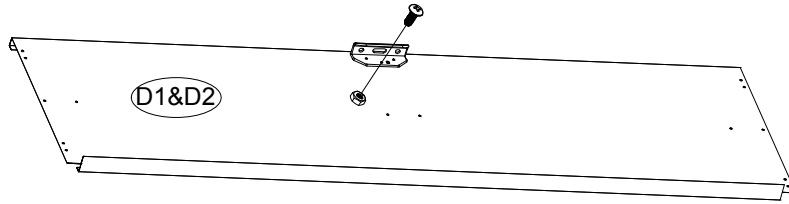

x2

NO.	PART	Qty.
20		6

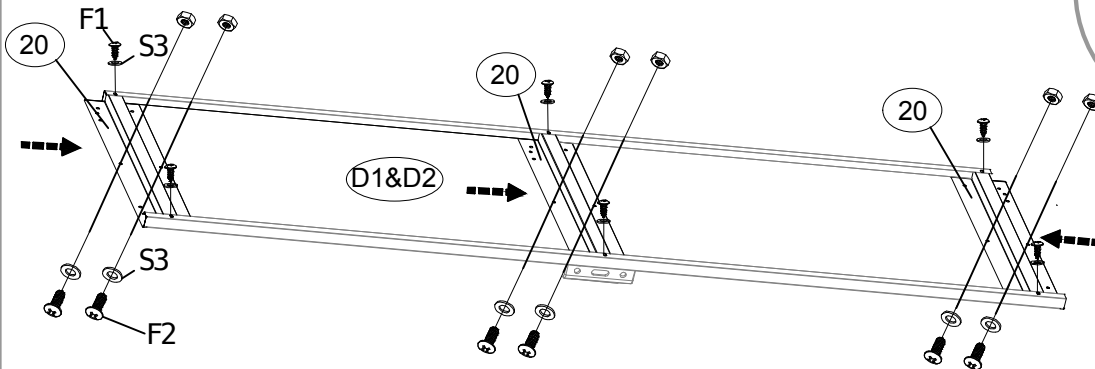

x2

NO.	PART	Qty.
GD		4

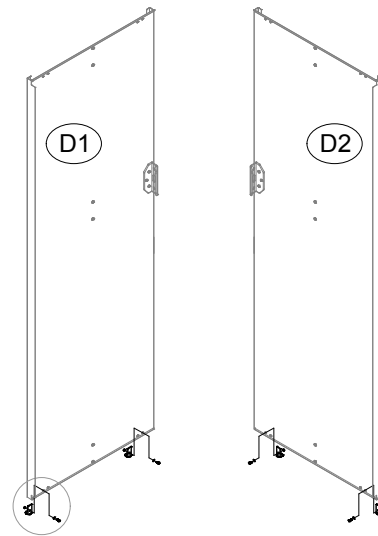
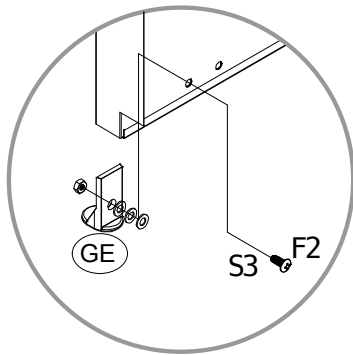

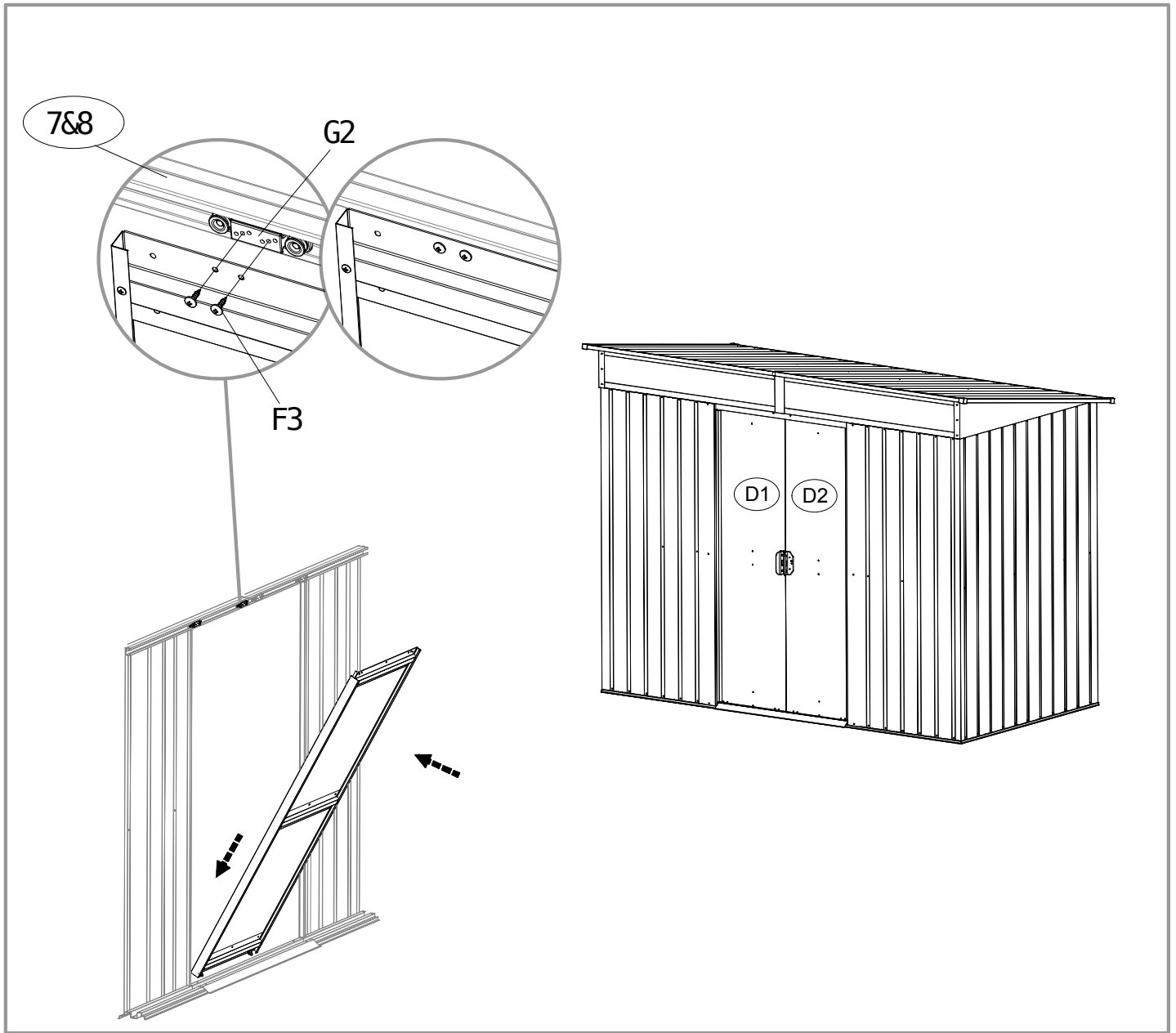

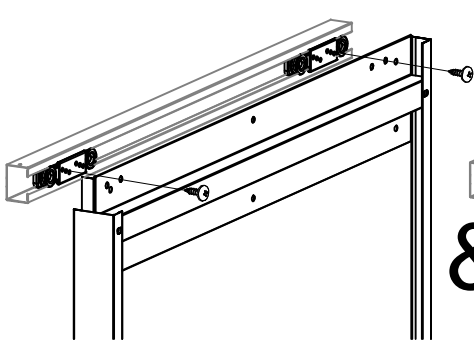
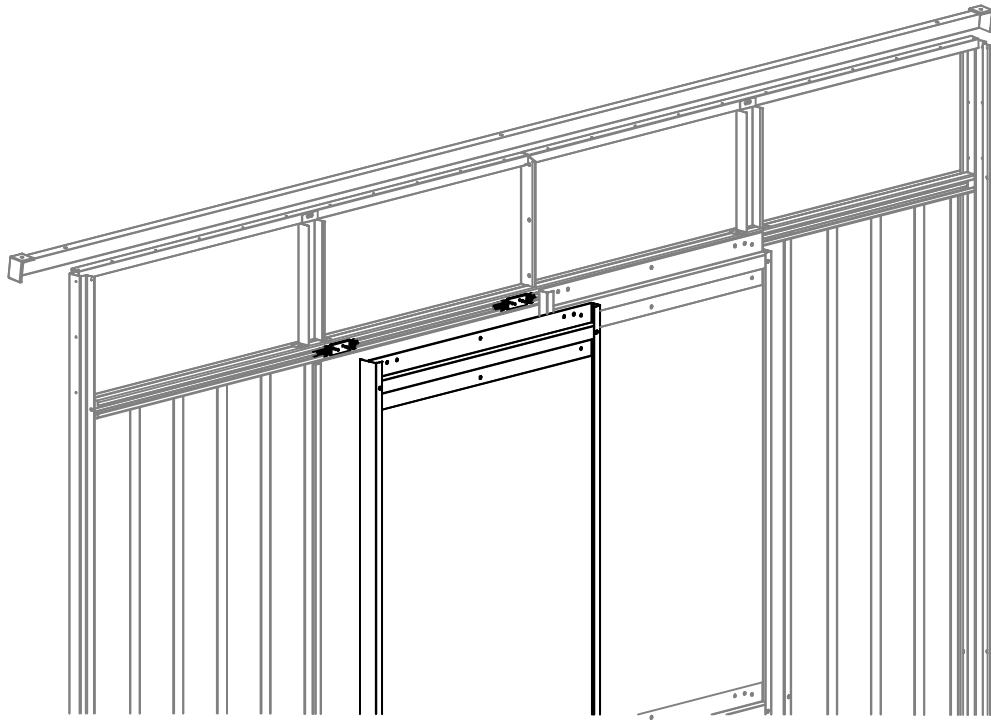
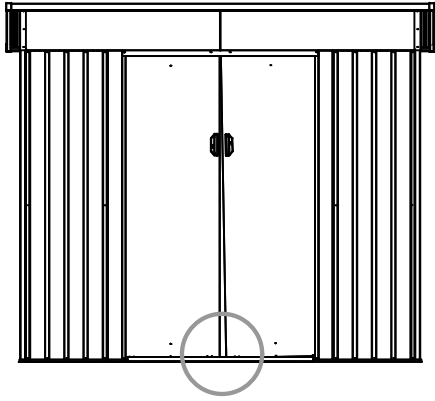

&

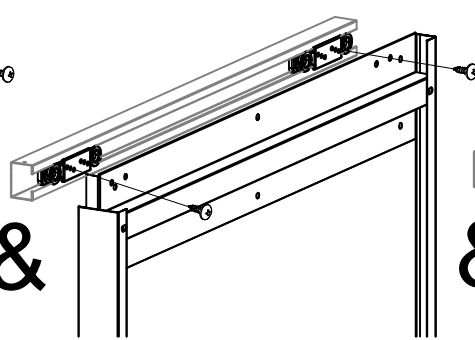

&

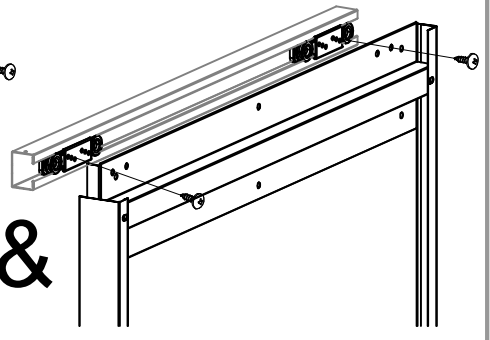



Metalgerätehaus

Fundamentbausatz

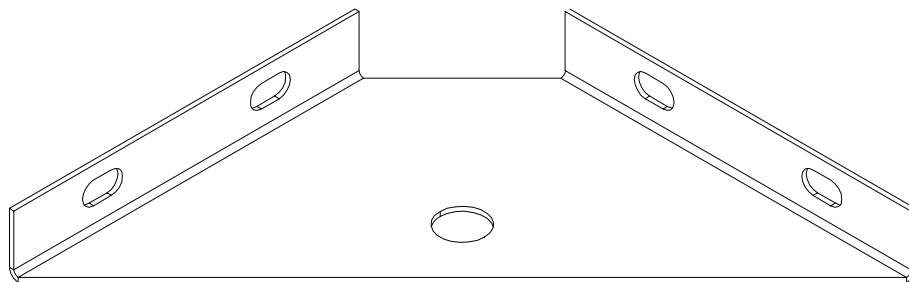
Montageanleitung



NO.	PART	Qty.
J1		4
F1		16

