

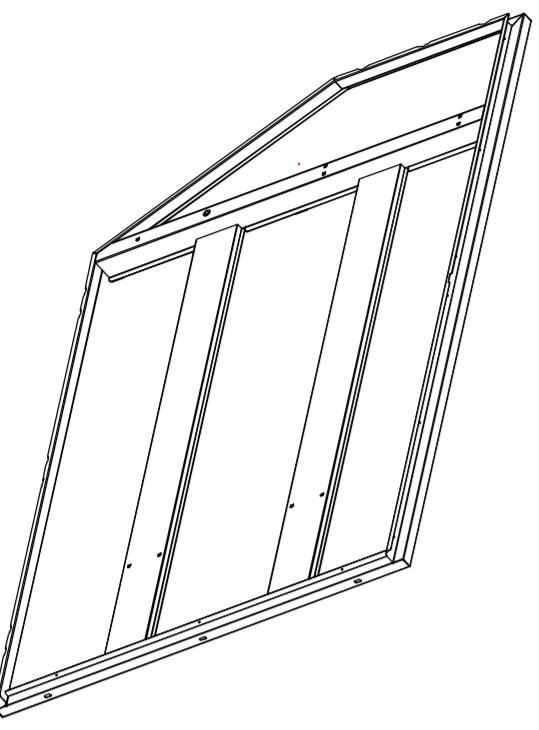

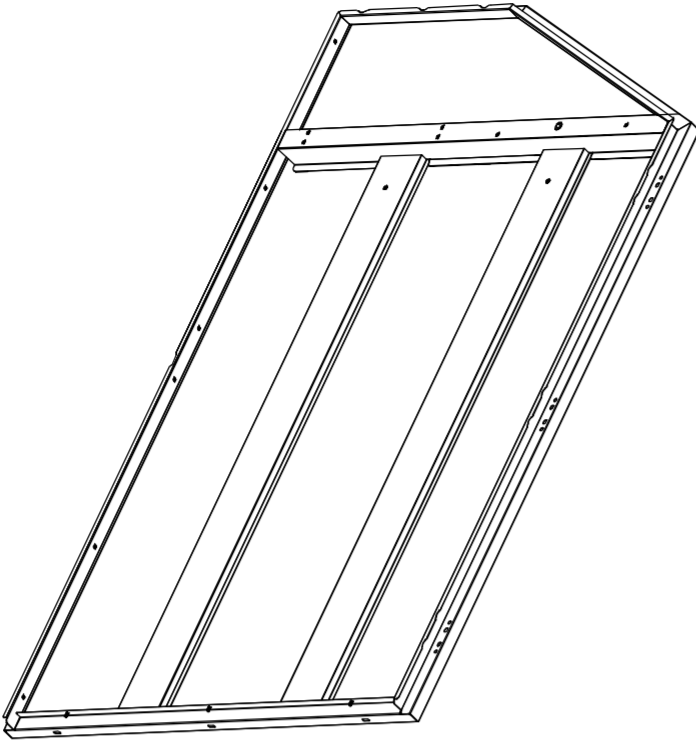
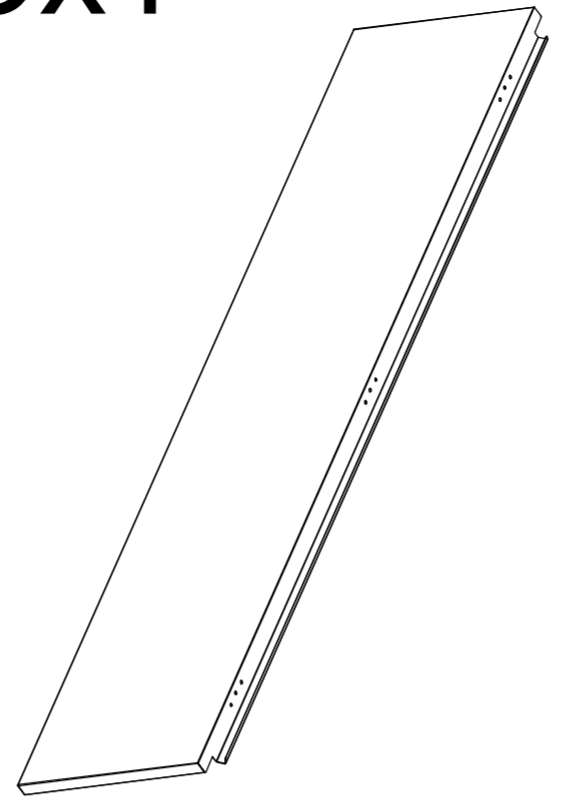
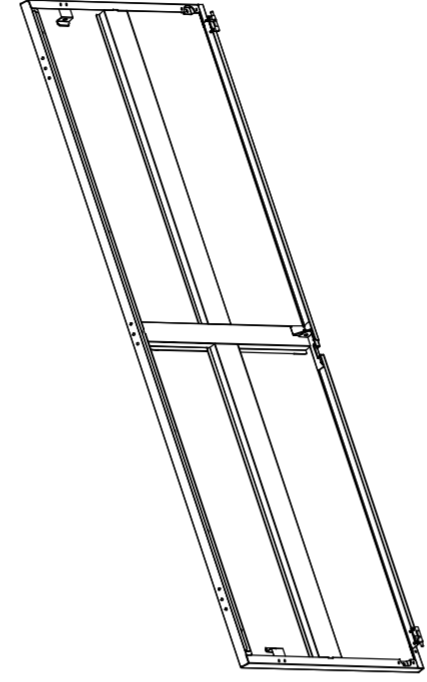
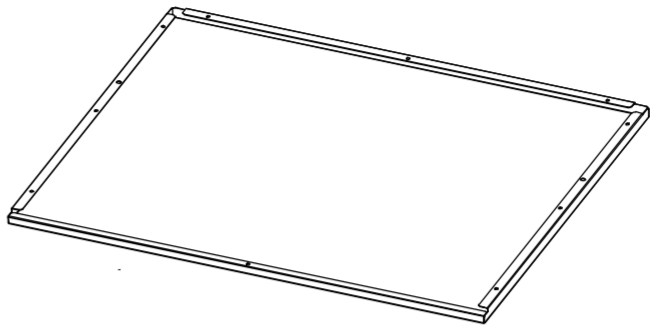
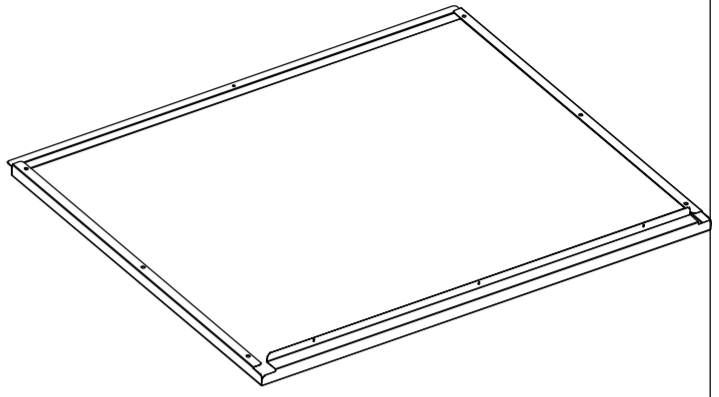
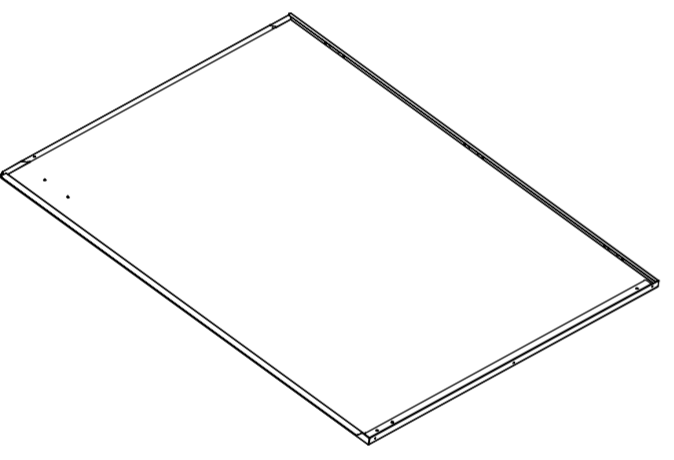
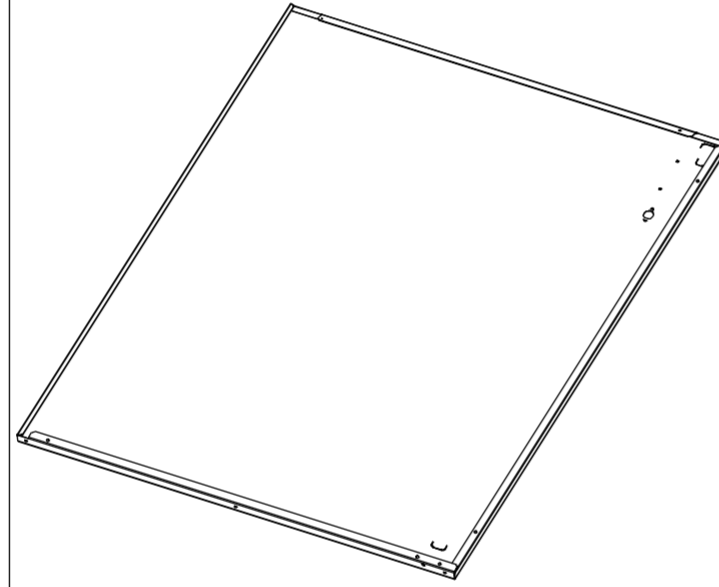
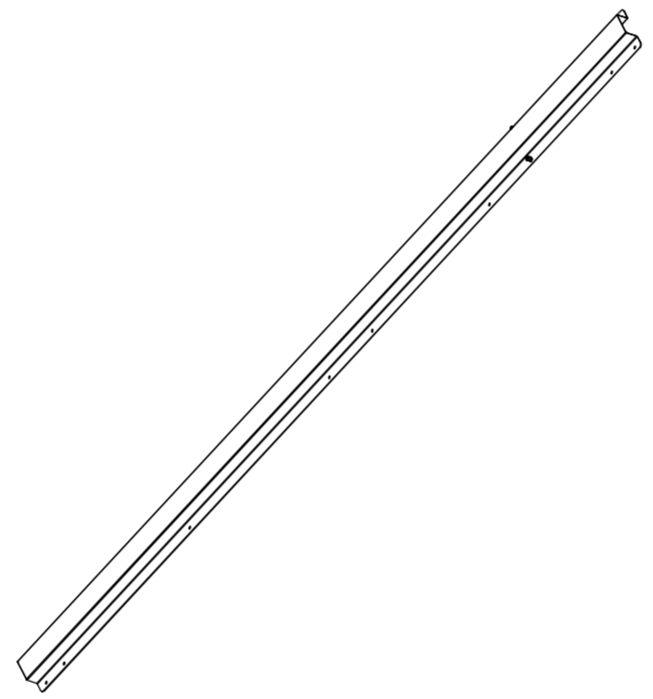
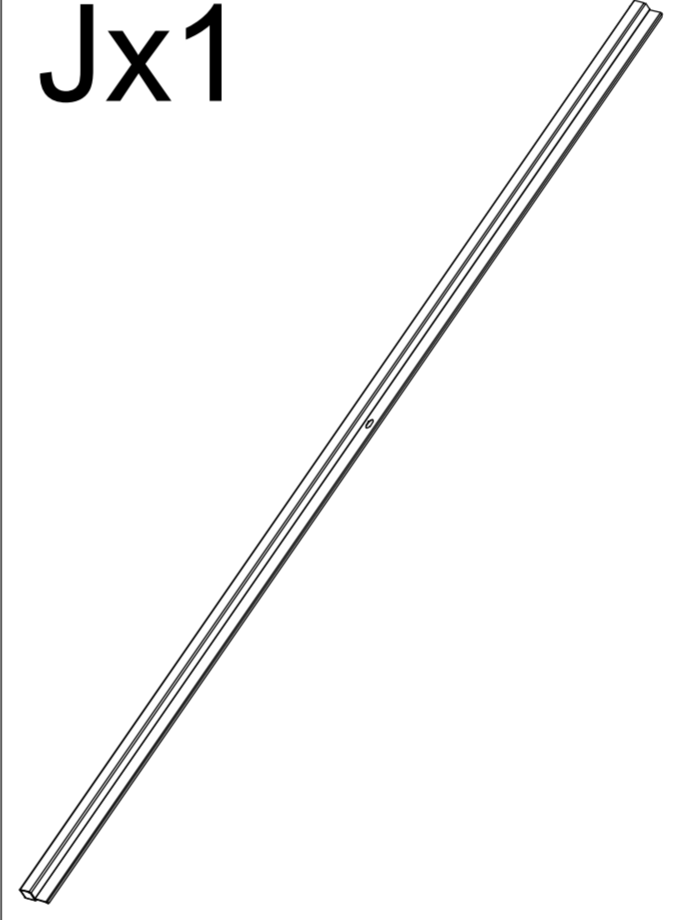
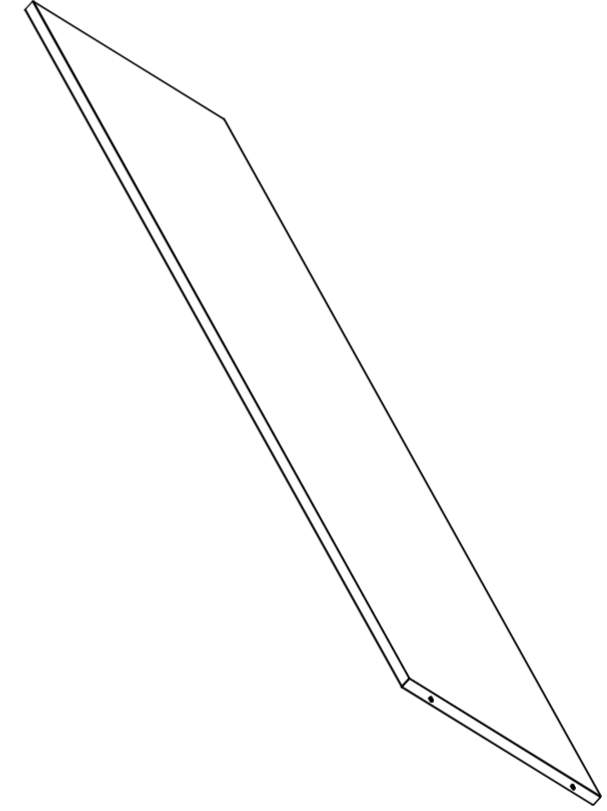
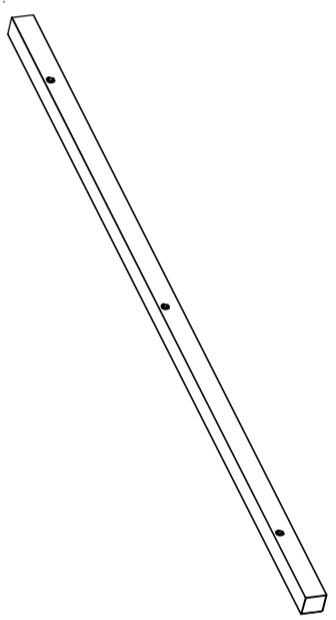
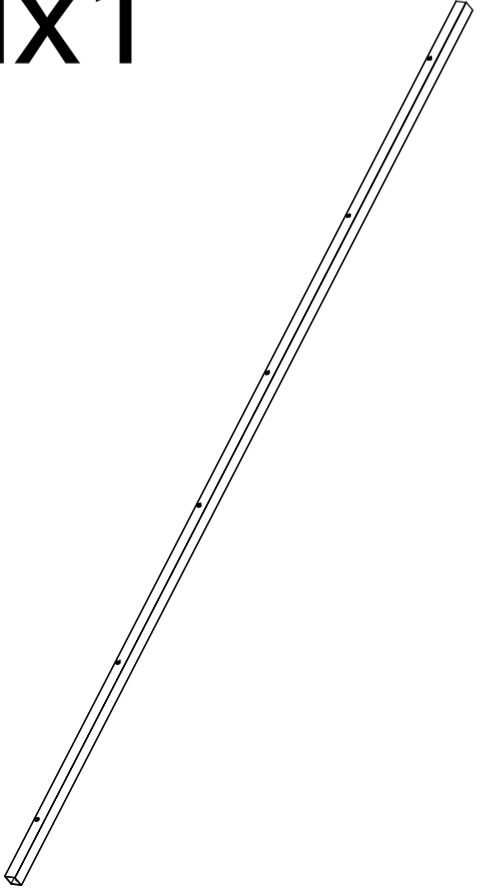
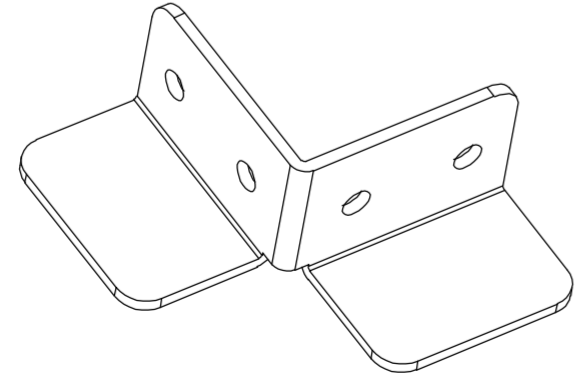
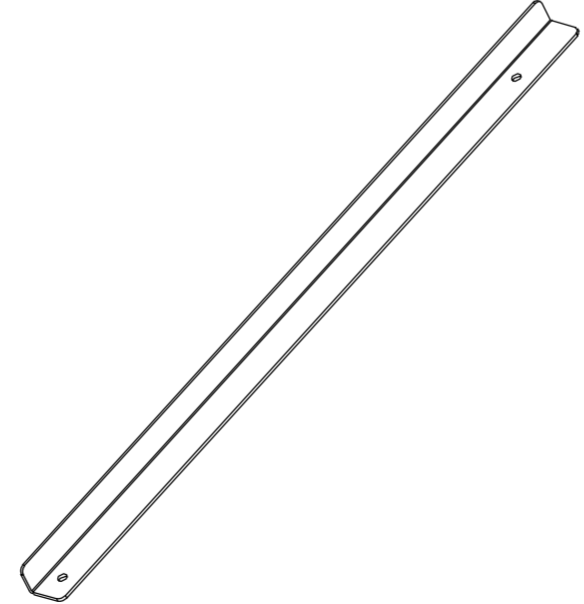
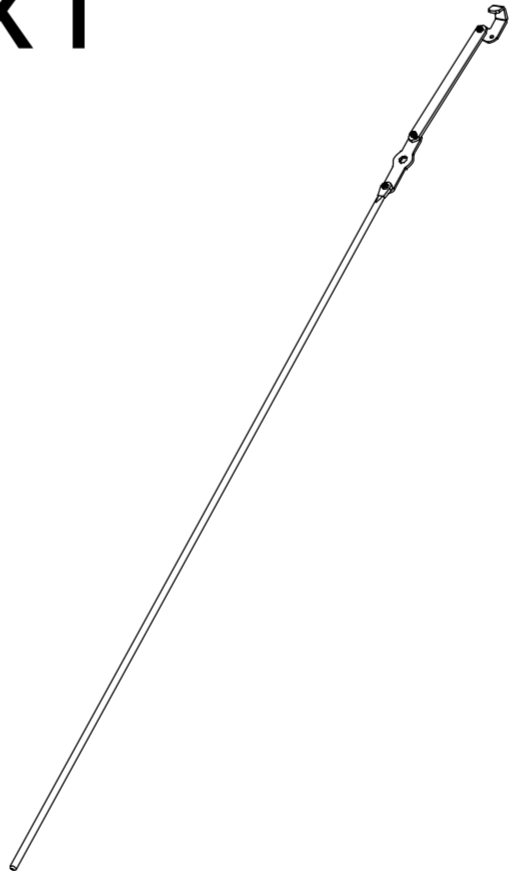
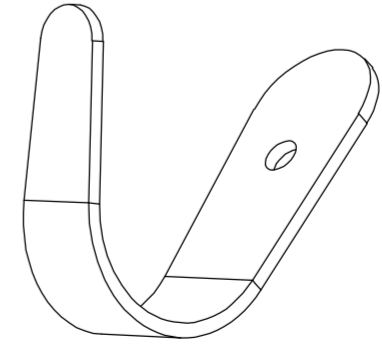
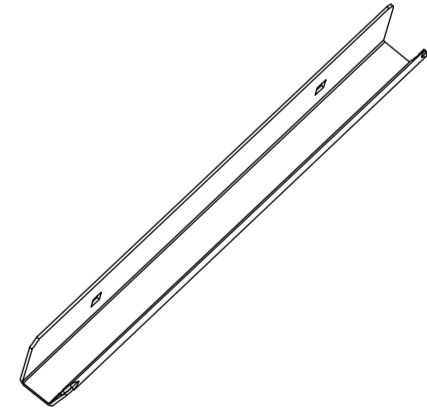
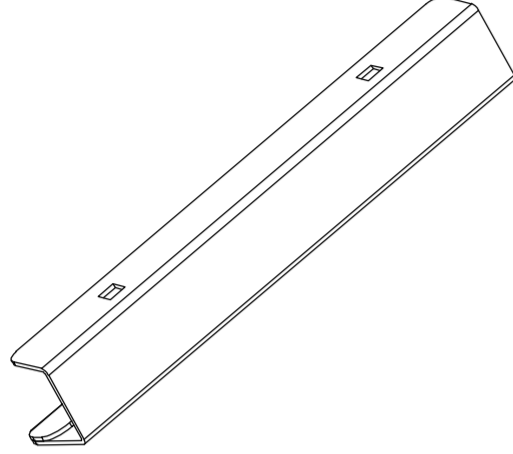
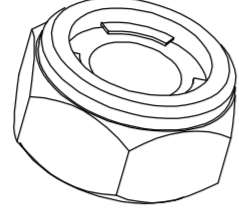
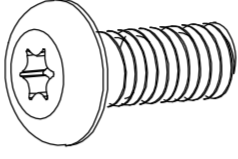
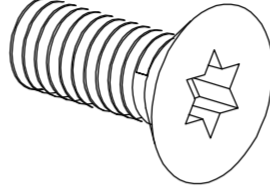
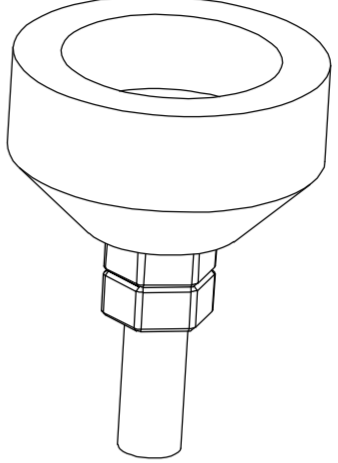
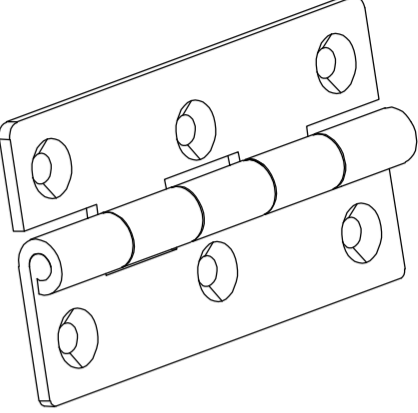
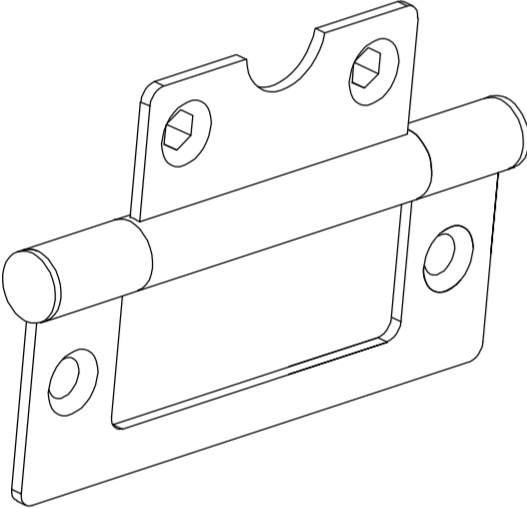
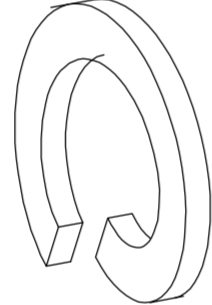
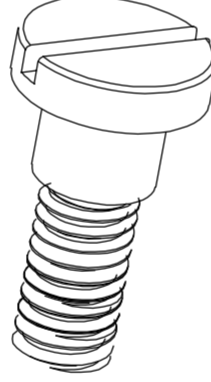

150Min

<p>Ax1</p> 	<p>Bx1</p> 	<p>Cx1</p> 	<p>Dx1</p> 	<p>Ex2</p> 	<p>Fx2</p> 
<p>Gx1</p> 	<p>Hx1</p> 	<p>Ix1</p> 	<p>Jx1</p> 	<p>Kx1</p> 	<p>Lx2</p> 
<p>Mx1</p> 	<p>Nx4</p> 	<p>Ox2</p> 	<p>Px1</p> 	<p>Qx4</p> 	<p>Rx1</p> 

<p>Sx2</p> 	<p>Tx6</p>  <p>M4</p>	<p>Ux89</p>  <p>M4x10mm</p>	<p>Vx42</p>  <p>M4x10mm</p>	<p>Wx2</p> 	<p>Xx3</p> 
<p>Yx6</p> 	<p>Zx4</p> 	<p>1x1</p> 	<p>2x7</p>  <p>Kunststoffe(12x6x1)</p>	<p>3x4</p> 	<p>4x2</p> 
<p>5x4</p>  <p>M4x16mm</p>	<p>6x4</p> 	<p>7x2</p> 	<p>8x1</p> 	<p>9x26</p>  <p>Metall(M4x12x1)</p>	<p>10x6</p> 

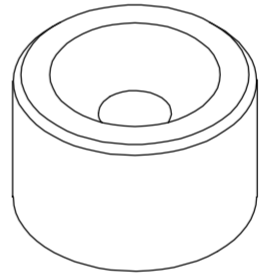
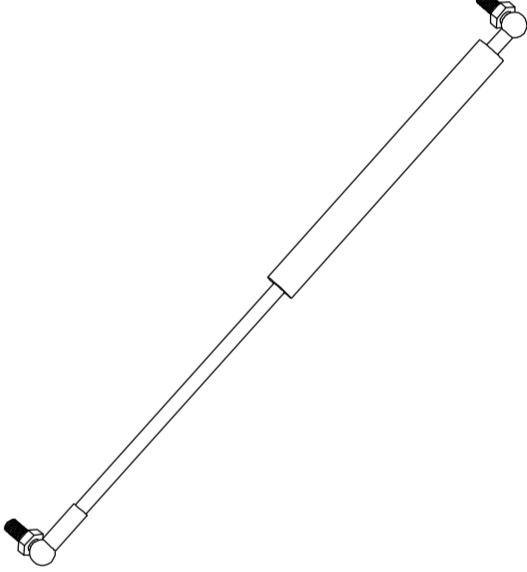
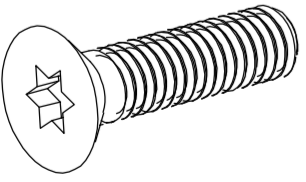
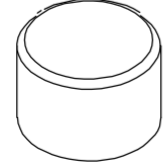
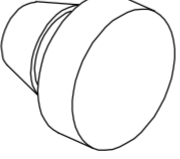
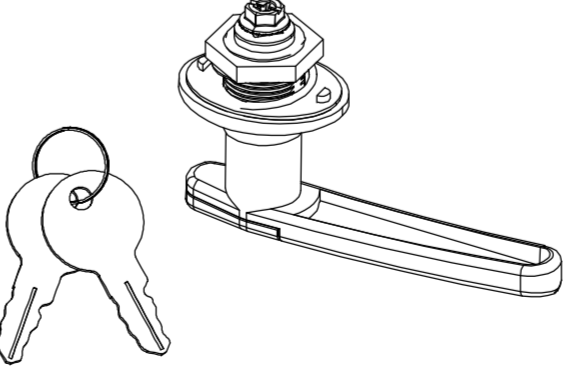
<p>11x6</p> 	<p>12x4</p> 	<p>13x4</p> 	<p>14x8</p>  <p>M8</p>	<p>15x8</p>  <p>Metall(M8x20x2)</p>	<p>16x4</p> 
--	--	--	--	---	--

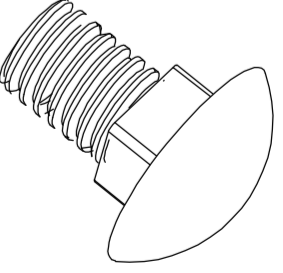
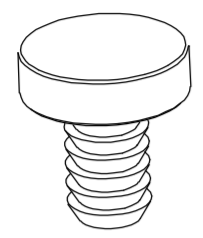
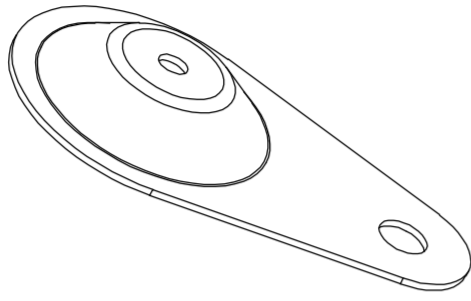
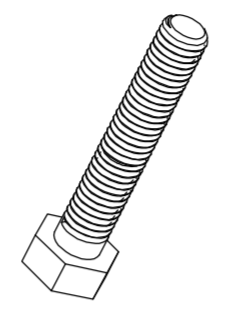
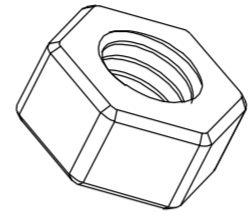
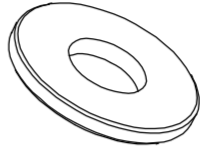
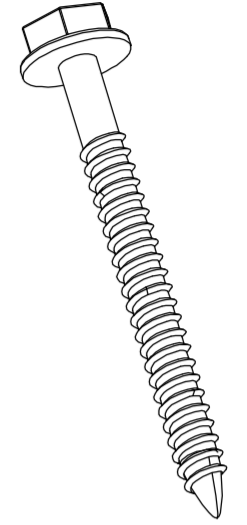
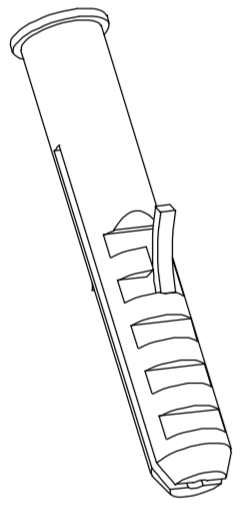
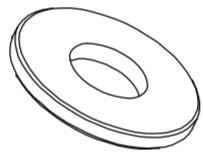
<p>17x4</p> 	<p>18x4</p>  <p>Metall(M6x20x1)</p>
---	---

Wenn der Grundplattenmechanismus nicht benötigt wird, können Sie diese drei Komponenten ignorieren.

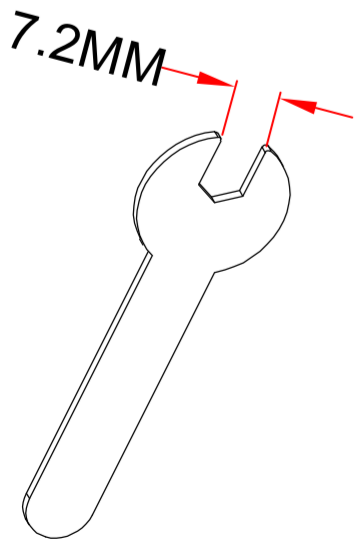
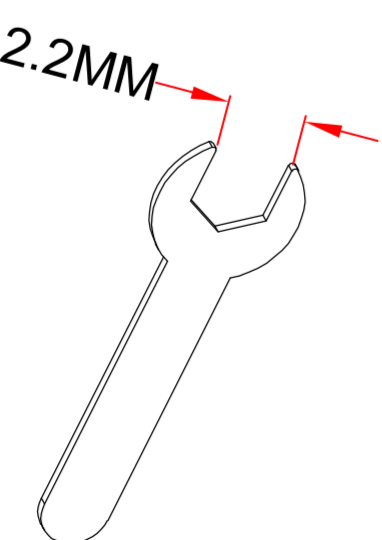
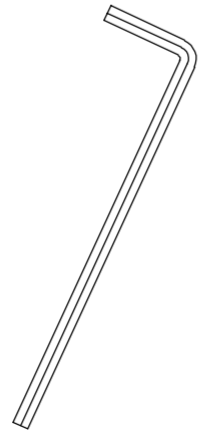
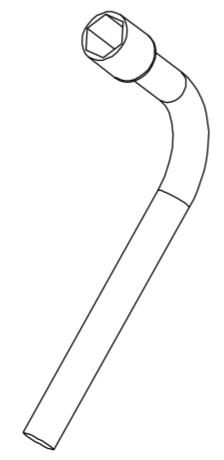
<p>19x1 Jedes Werkzeug ist mit einem ausgestattet.</p>			
 <p>7.2MM</p> <p>Gabel schlüssel M4-Mutter</p>	 <p>12.2MM</p> <p>Gabelschlüssel M8-Mutter in Gasfeder</p>	 <p>Torx-Schlüssel M4 Schraube</p>	 <p>Steckschlüssel M4-Mutter</p>

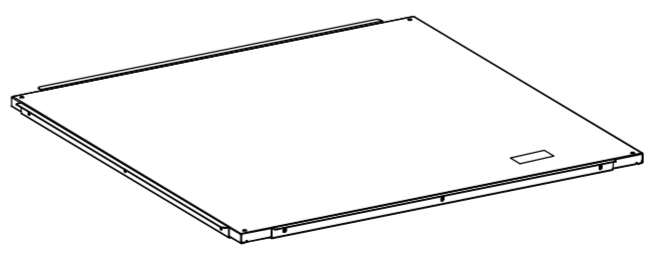
<p>20x1</p> 
--

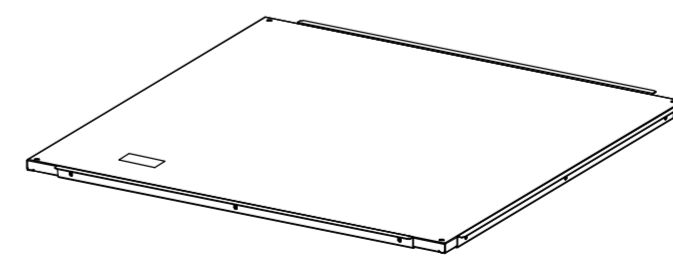
<p>21x1</p> 
--

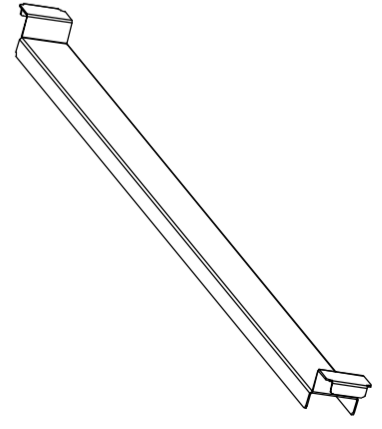
<p>22x1</p> 
--

Schritt1

ITEM	Qty
M	1
N	4
L	2
U	16
J	1
9	16

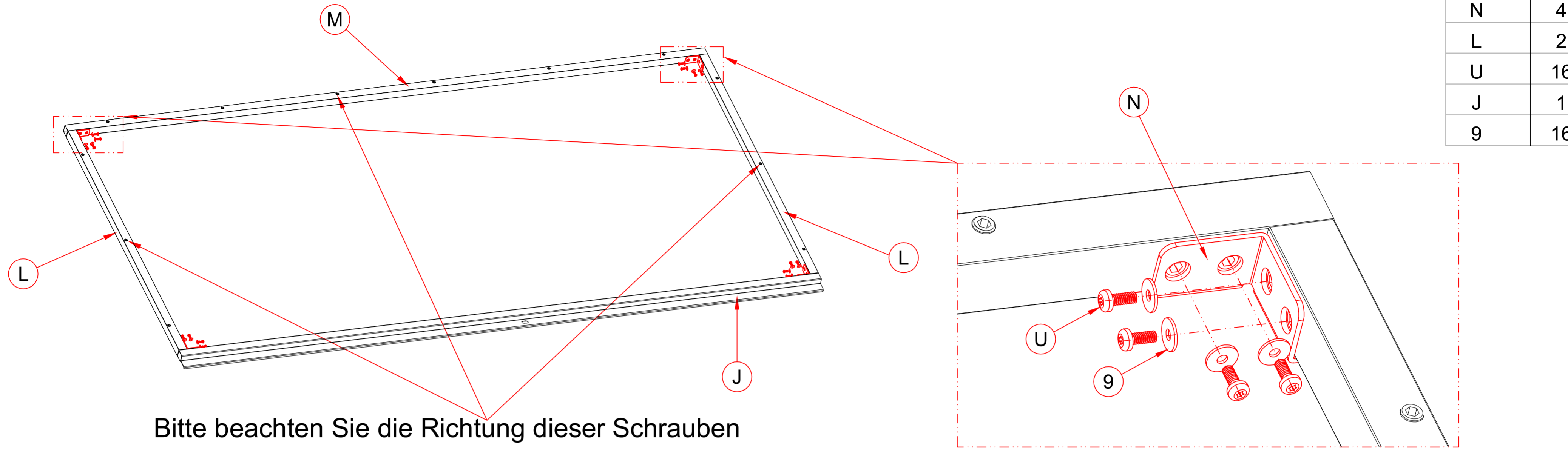

Bitte beachten Sie die Richtung dieser Schrauben

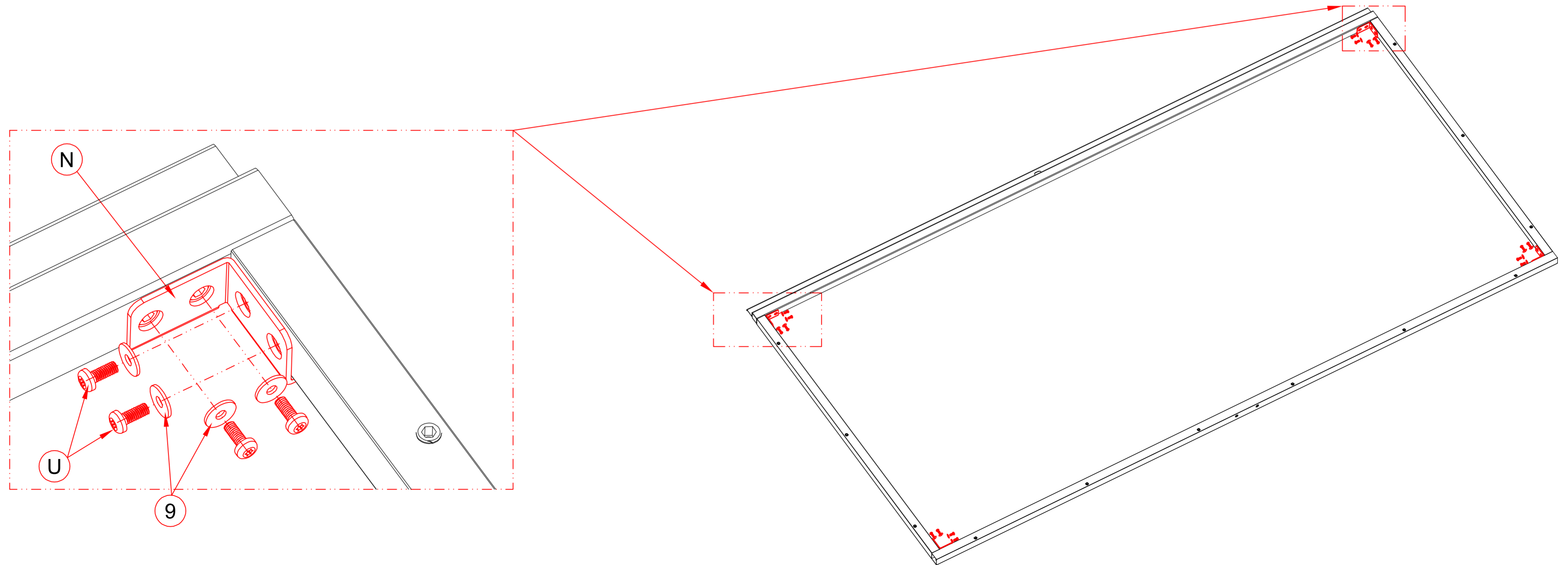

Schritt2

ITEM	Qty
12	4
13	4
14	8
15	8

Vier Montagesätze

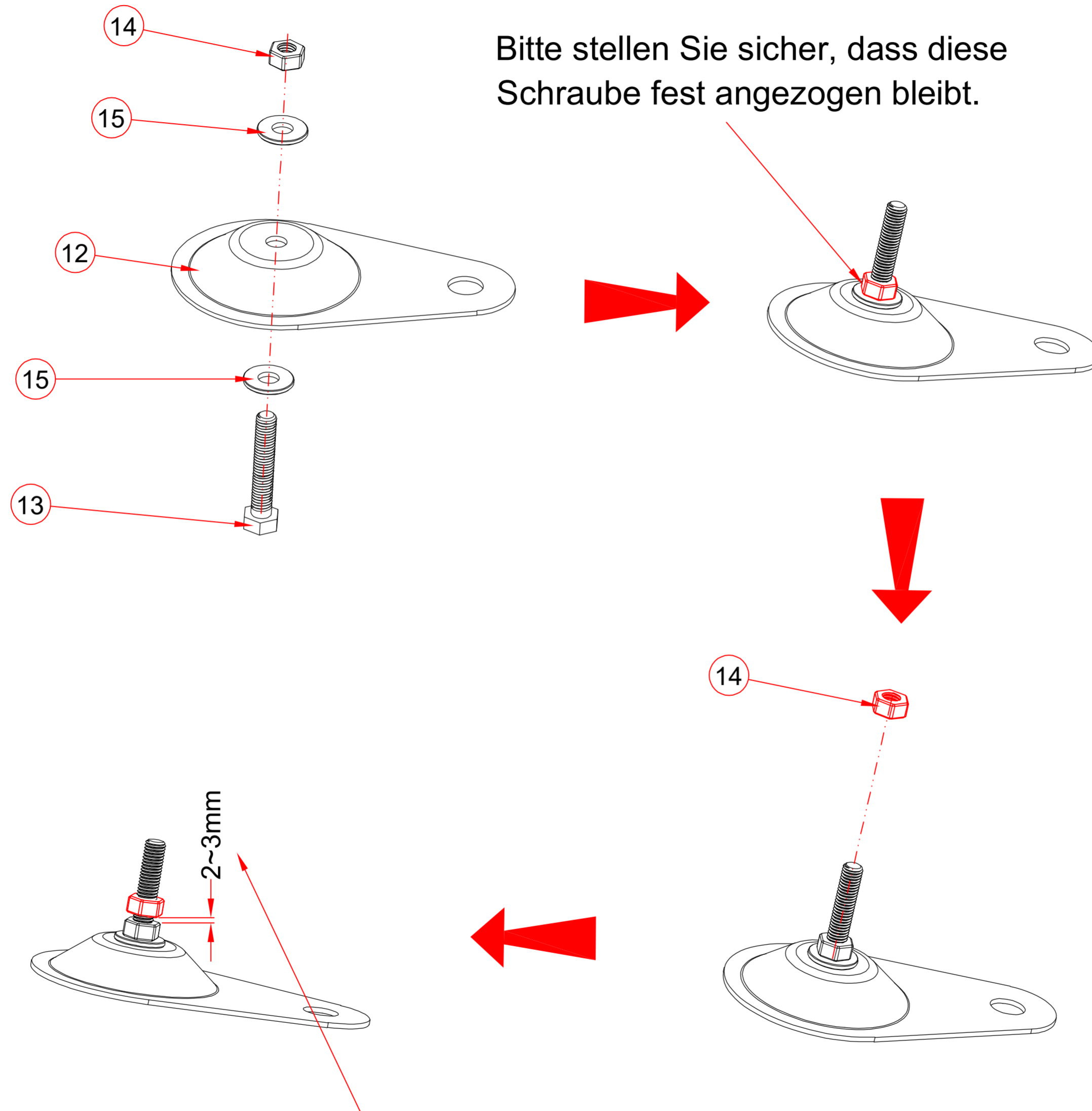

Bitte stellen Sie sicher, dass diese Schraube fest angezogen bleibt.

Bitte halten Sie einen Abstand von 2 bis 3 Millimetern ein, um Anpassungen an der Balance der Grundplatte zu ermöglichen.

Schritt3

ITEM	Qty
W	2
12	4

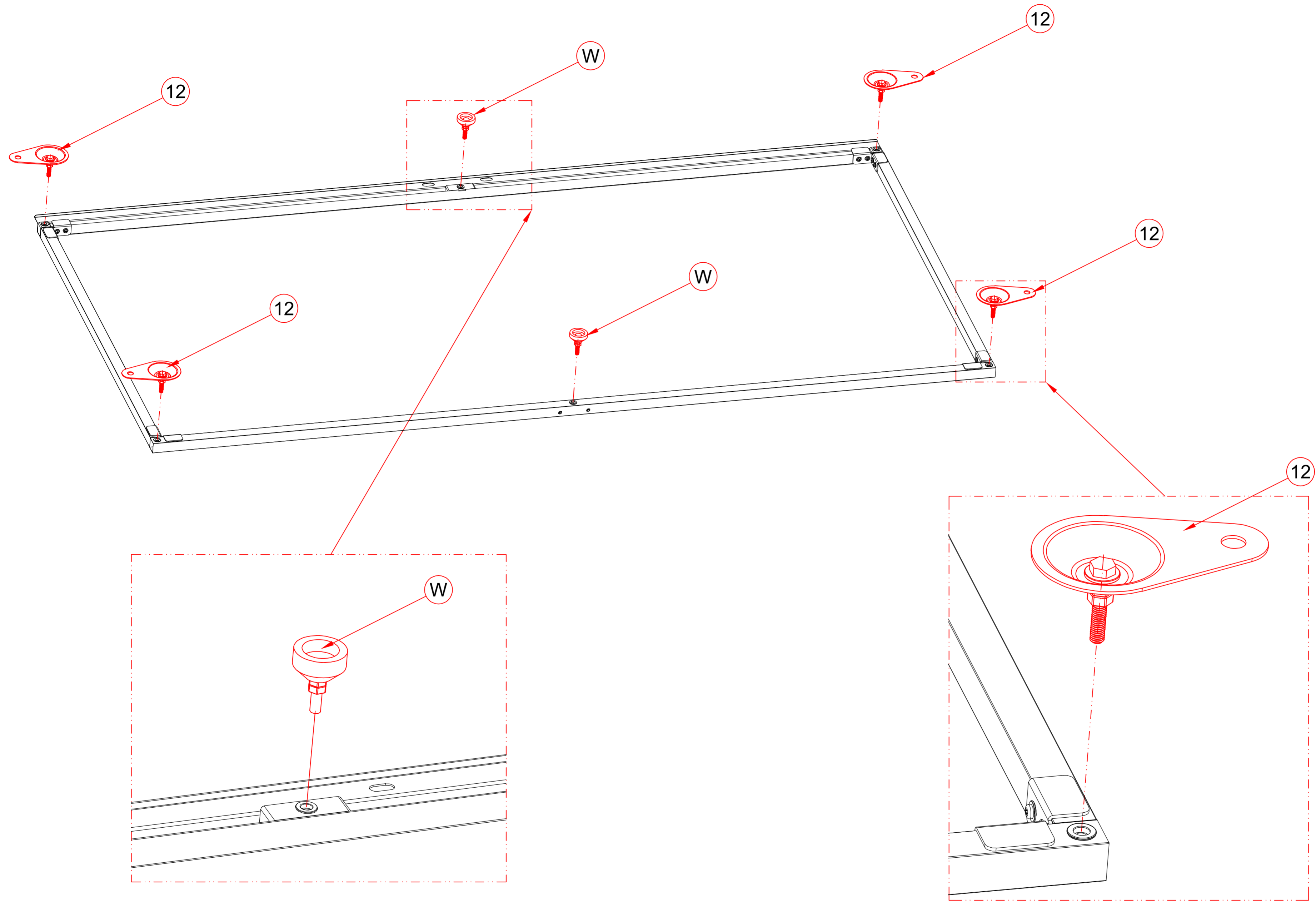

Schritt4

ITEM	Qty
I	1
U	2

Öffnungsrichtung

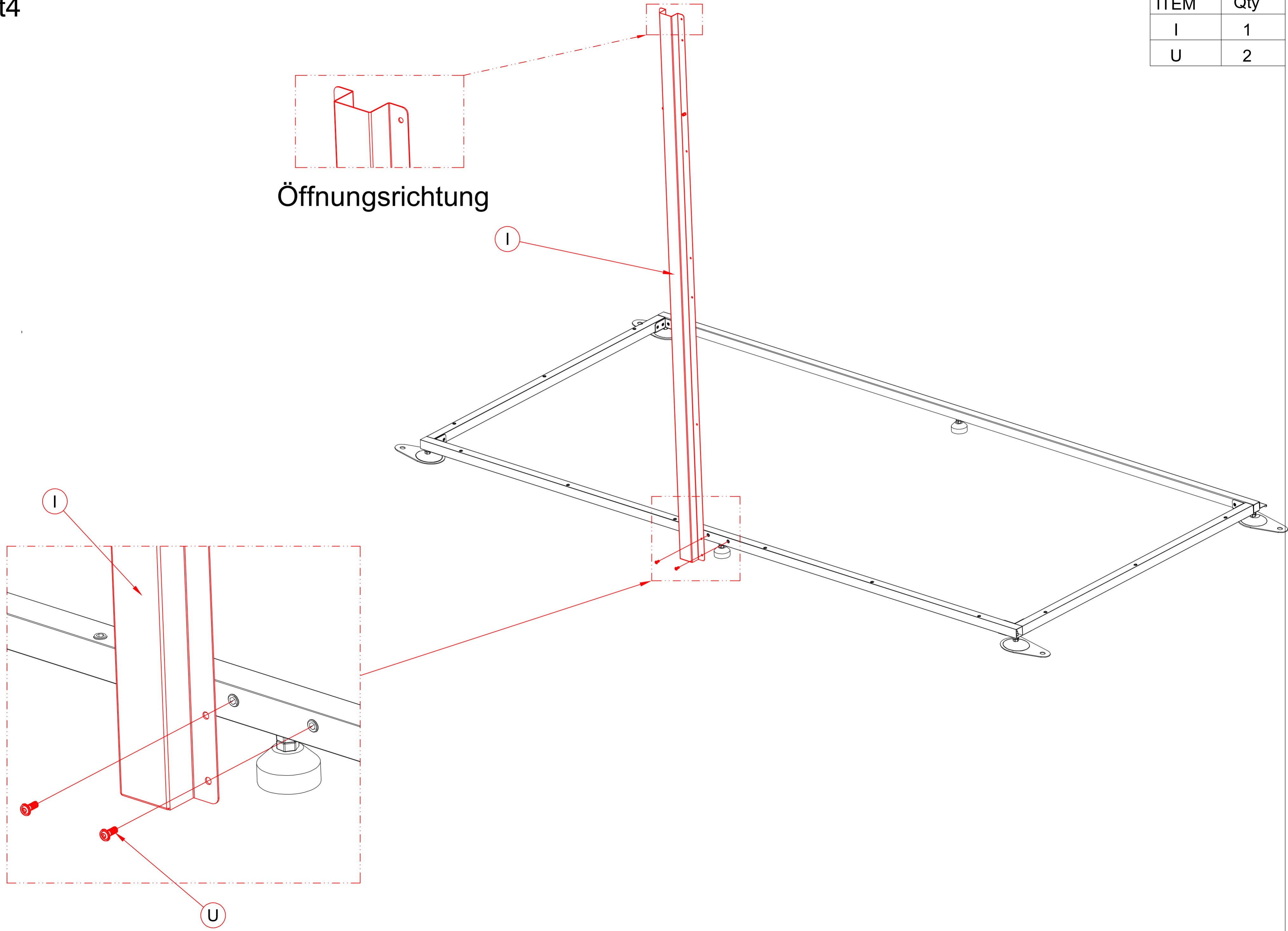

Schritt5

ITEM	Qty
F	2
U	12

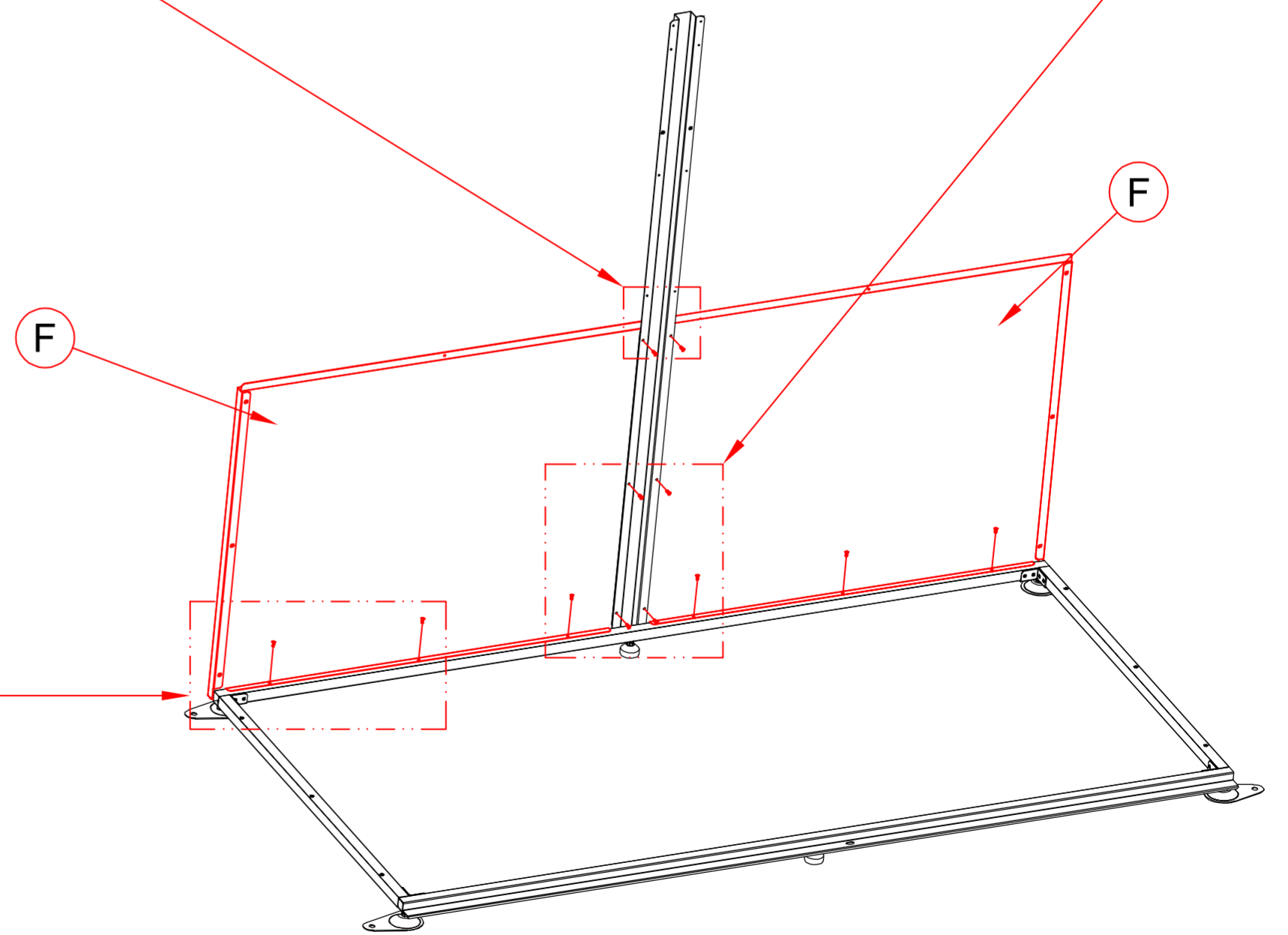
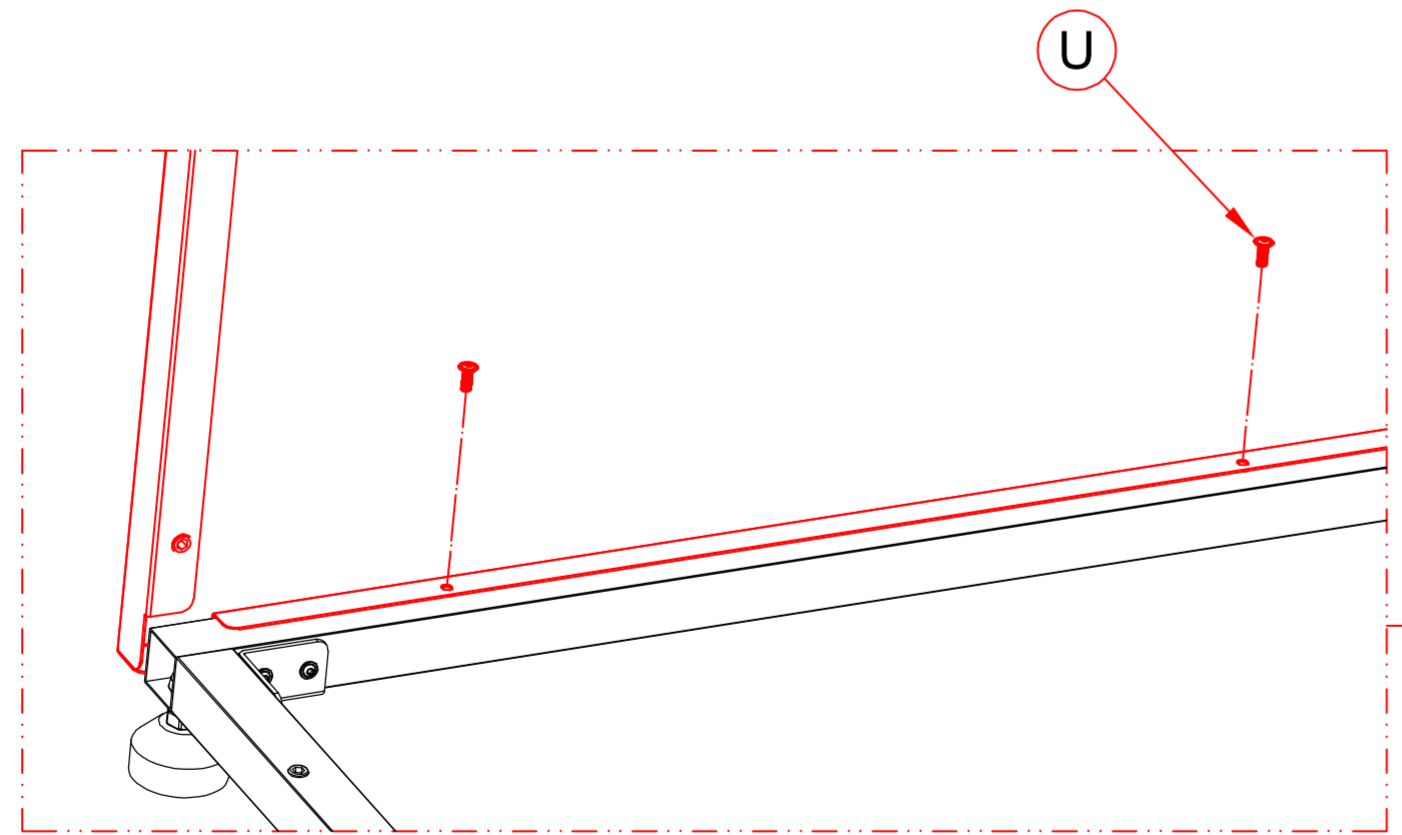
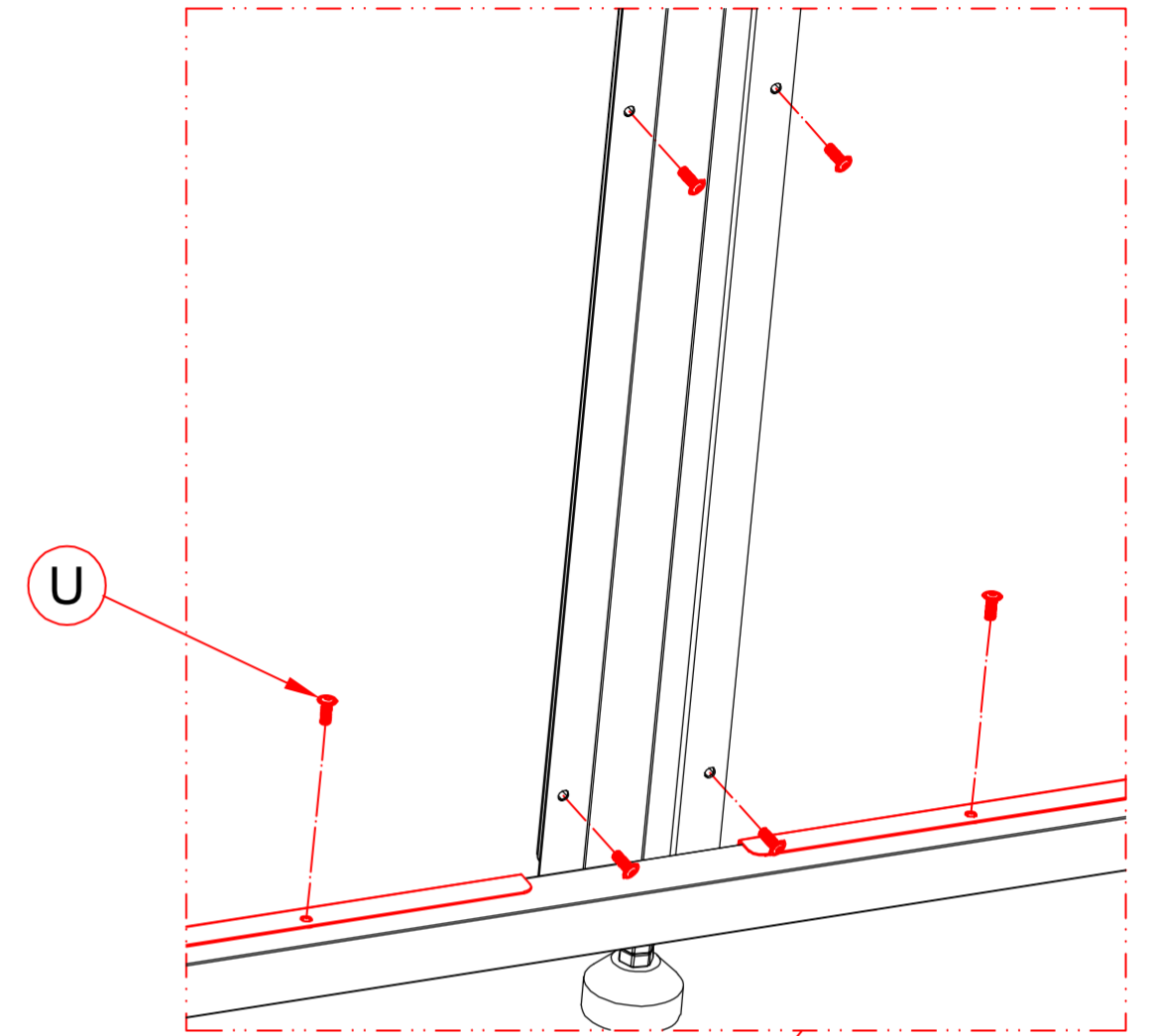
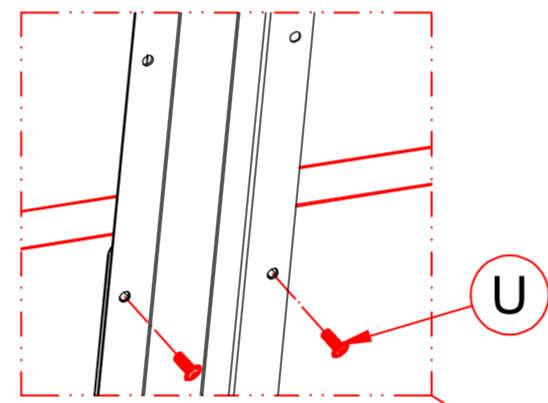
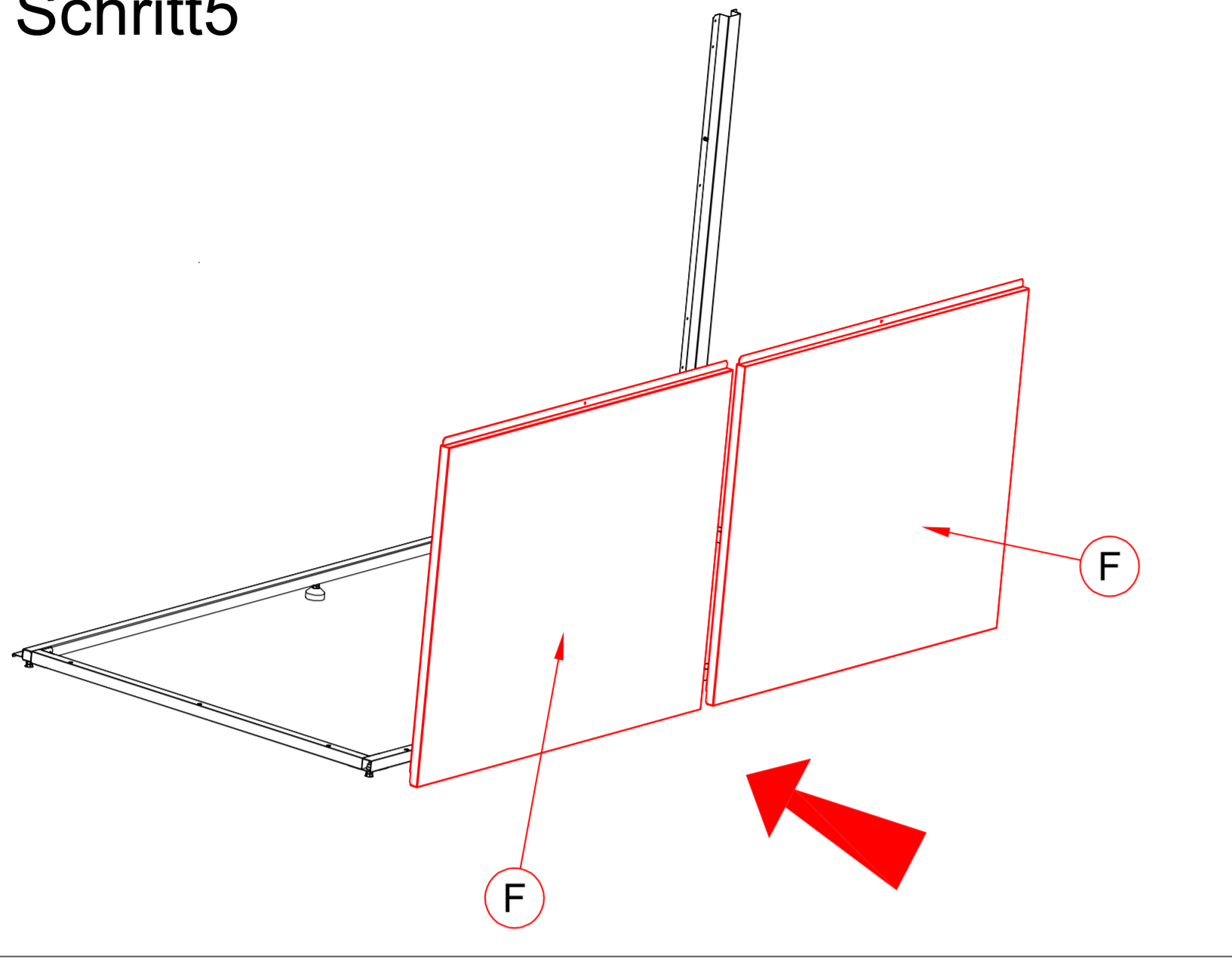

Schritt6

ITEM	Qty
A	1
O	1
U	2
9	2

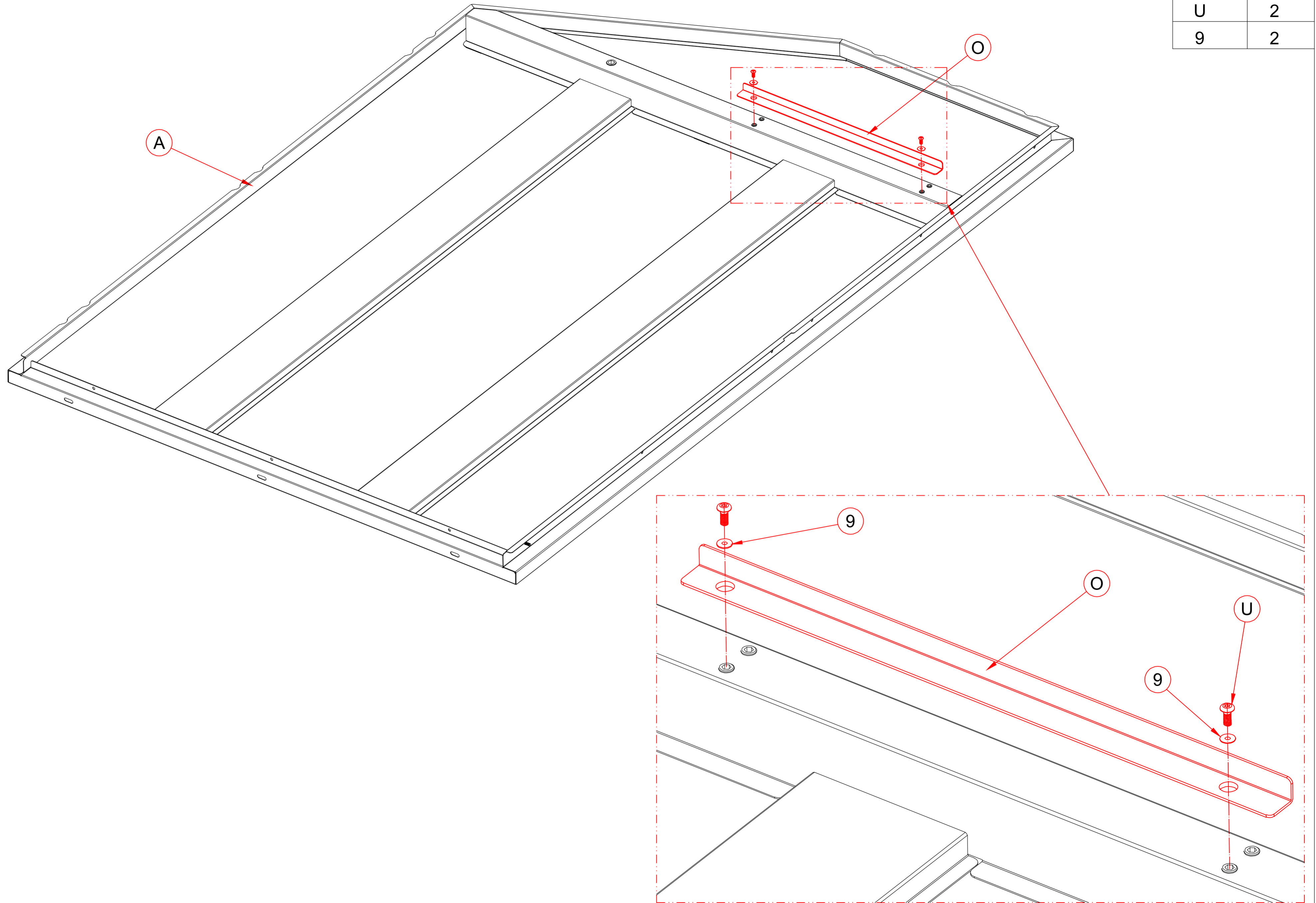

Schritt7

ITEM	Qty
B	1
O	1
Q	2
U	4
9	4

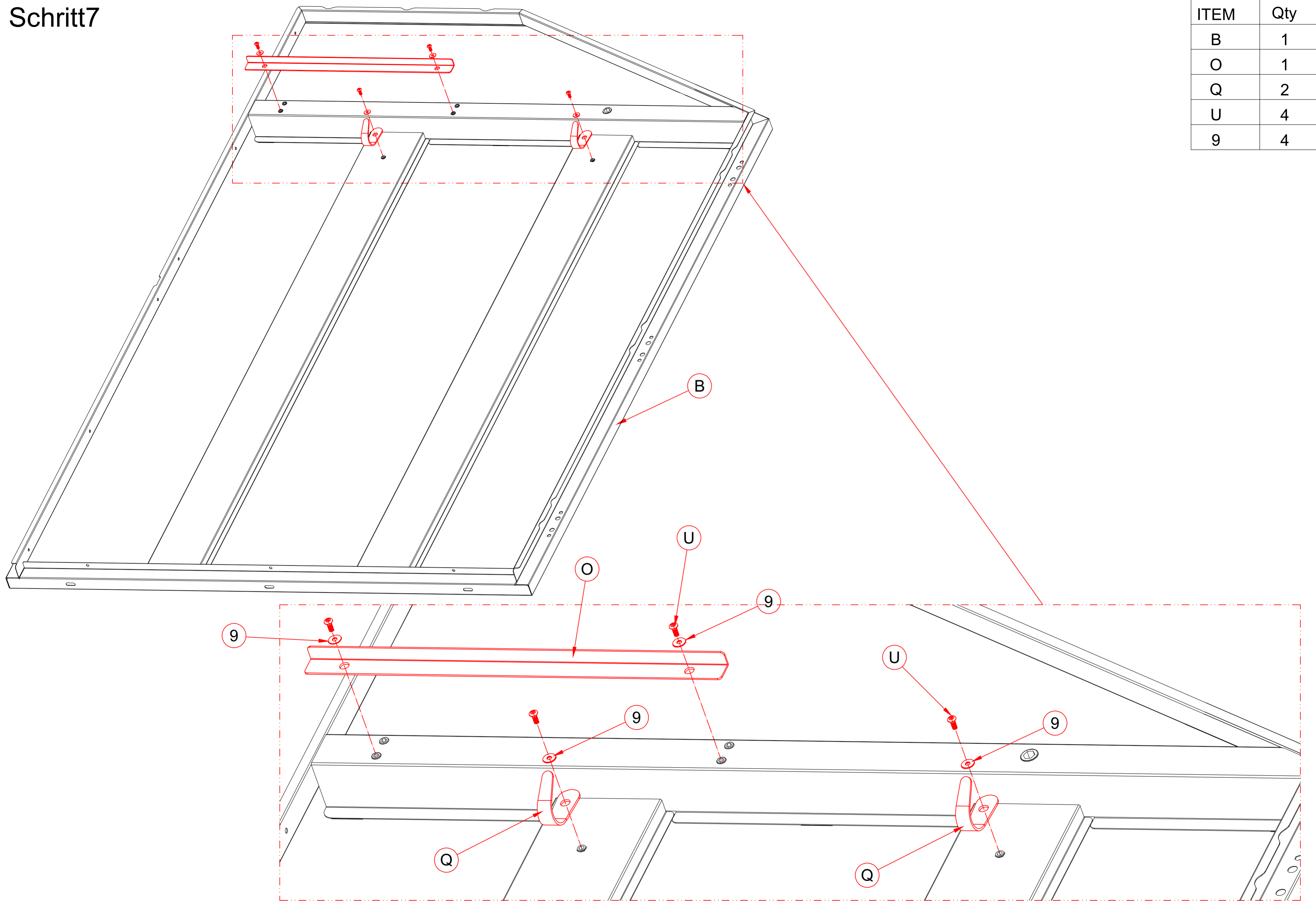

Schritt8

ITEM	Qty
A	1
U	6

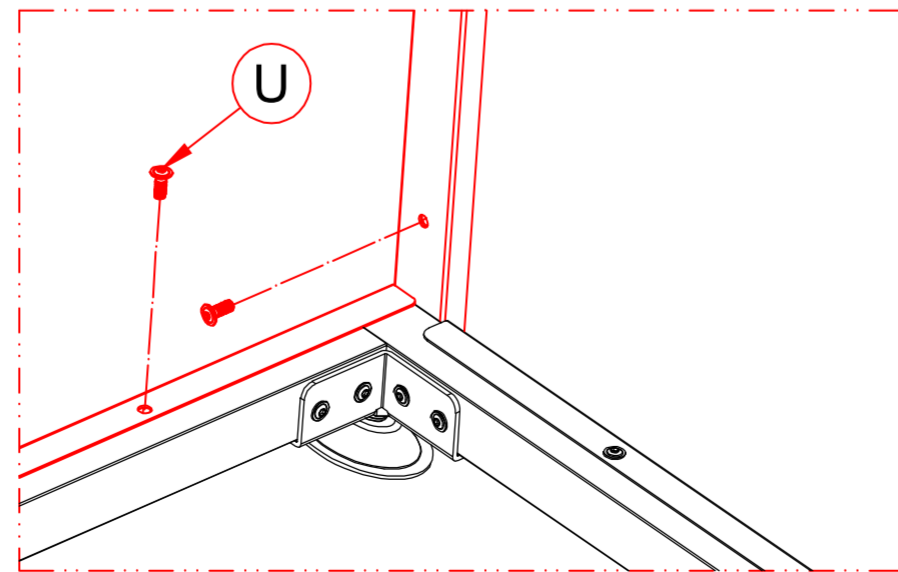
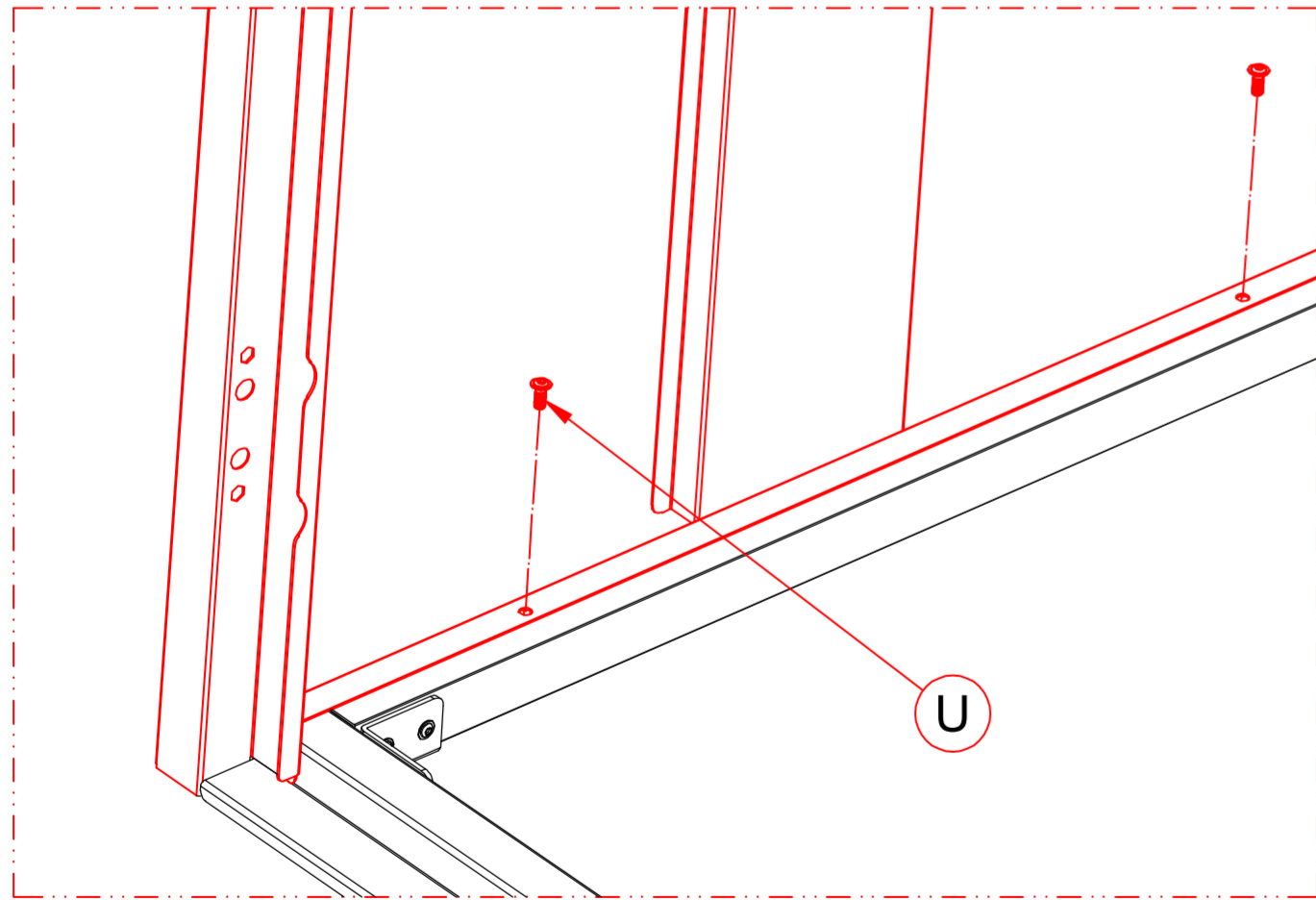
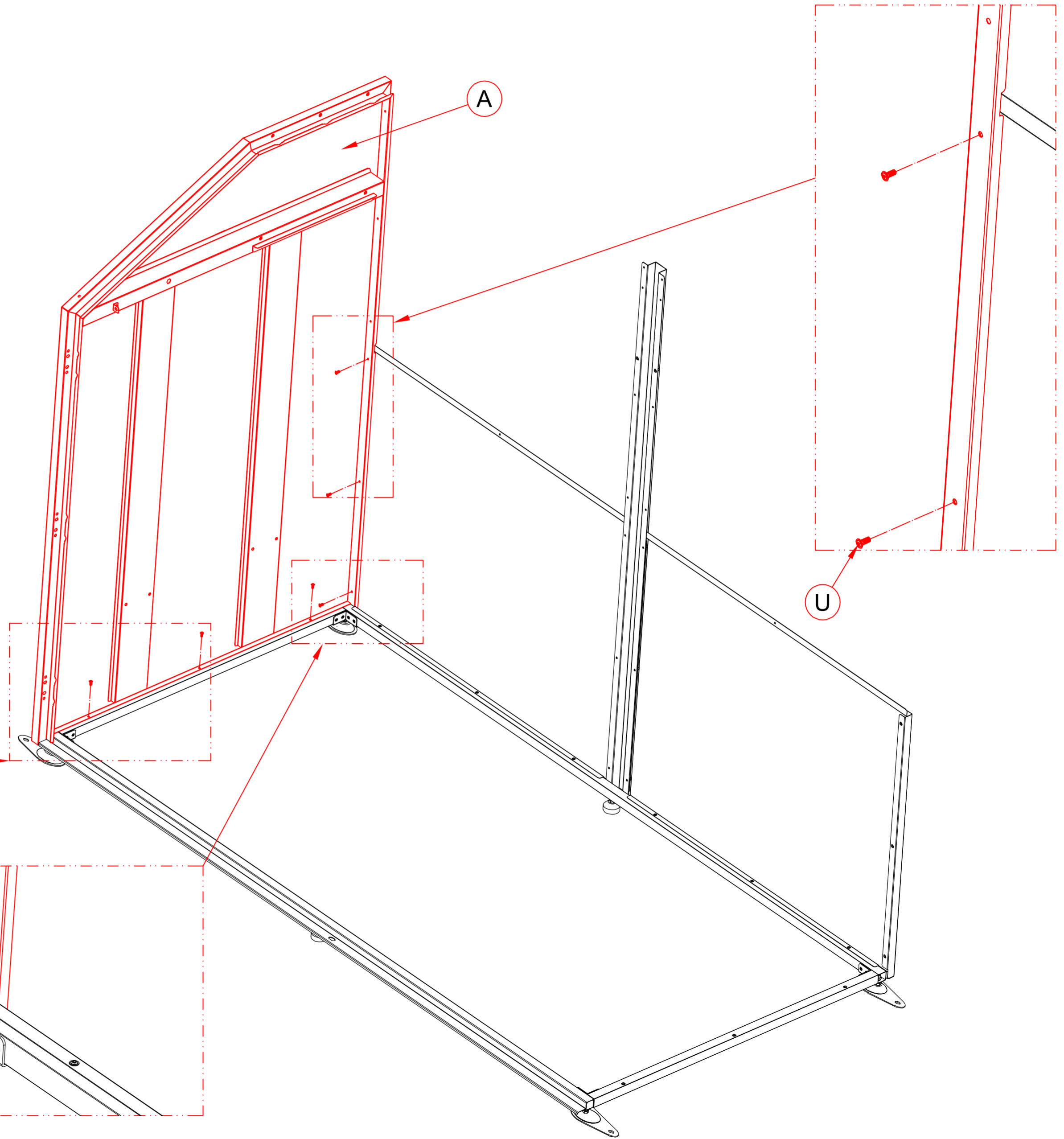
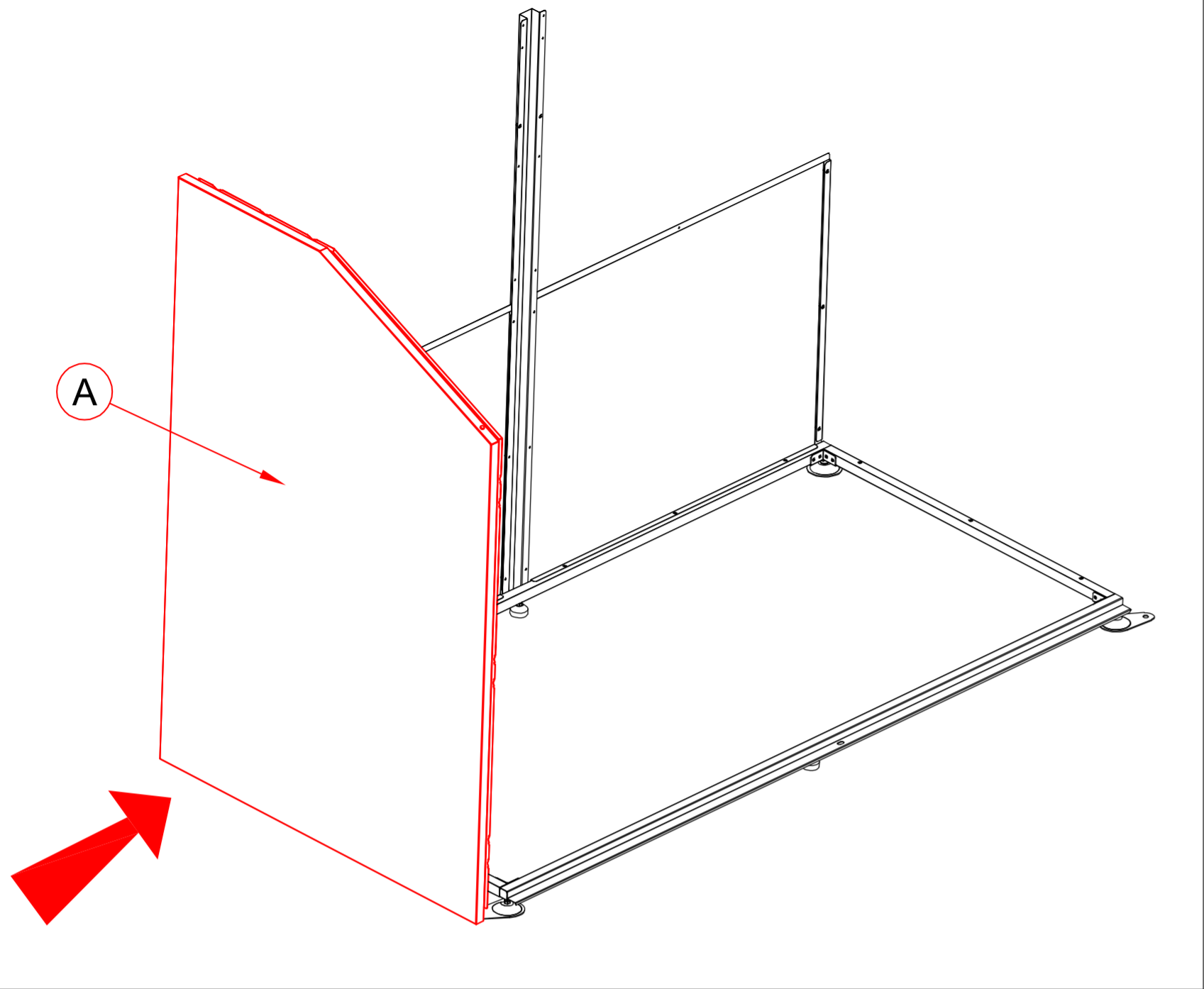

Schritt9

ITEM	Qty
B	1
U	6

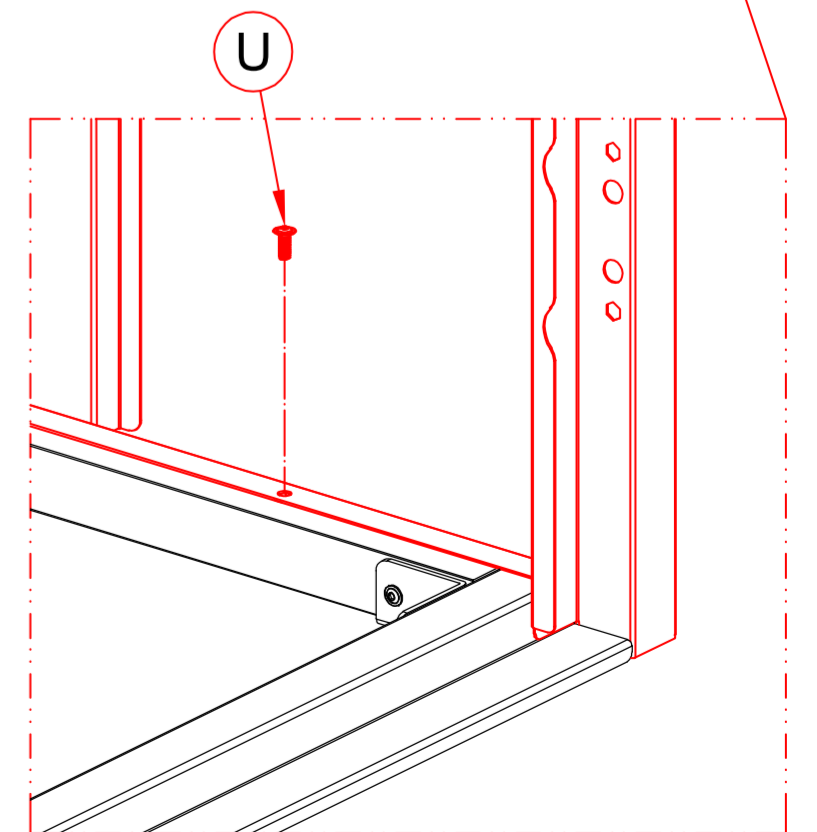
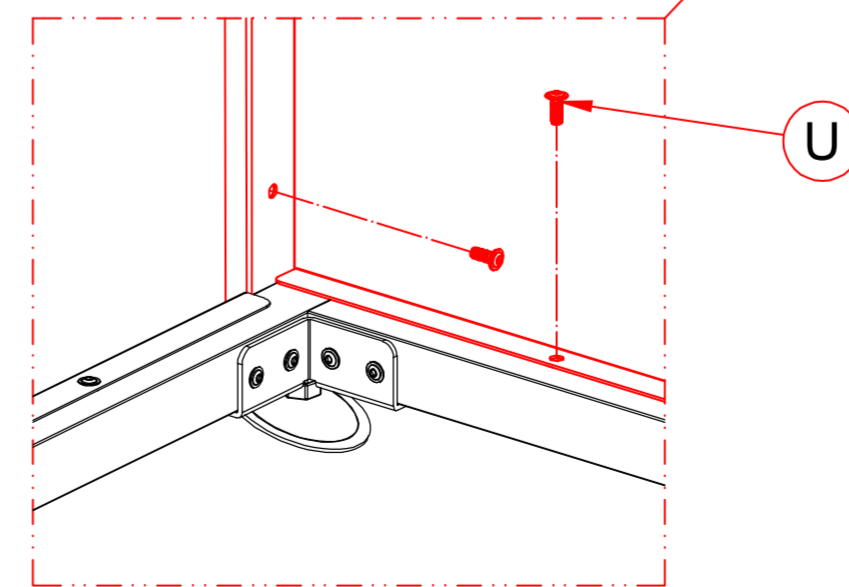
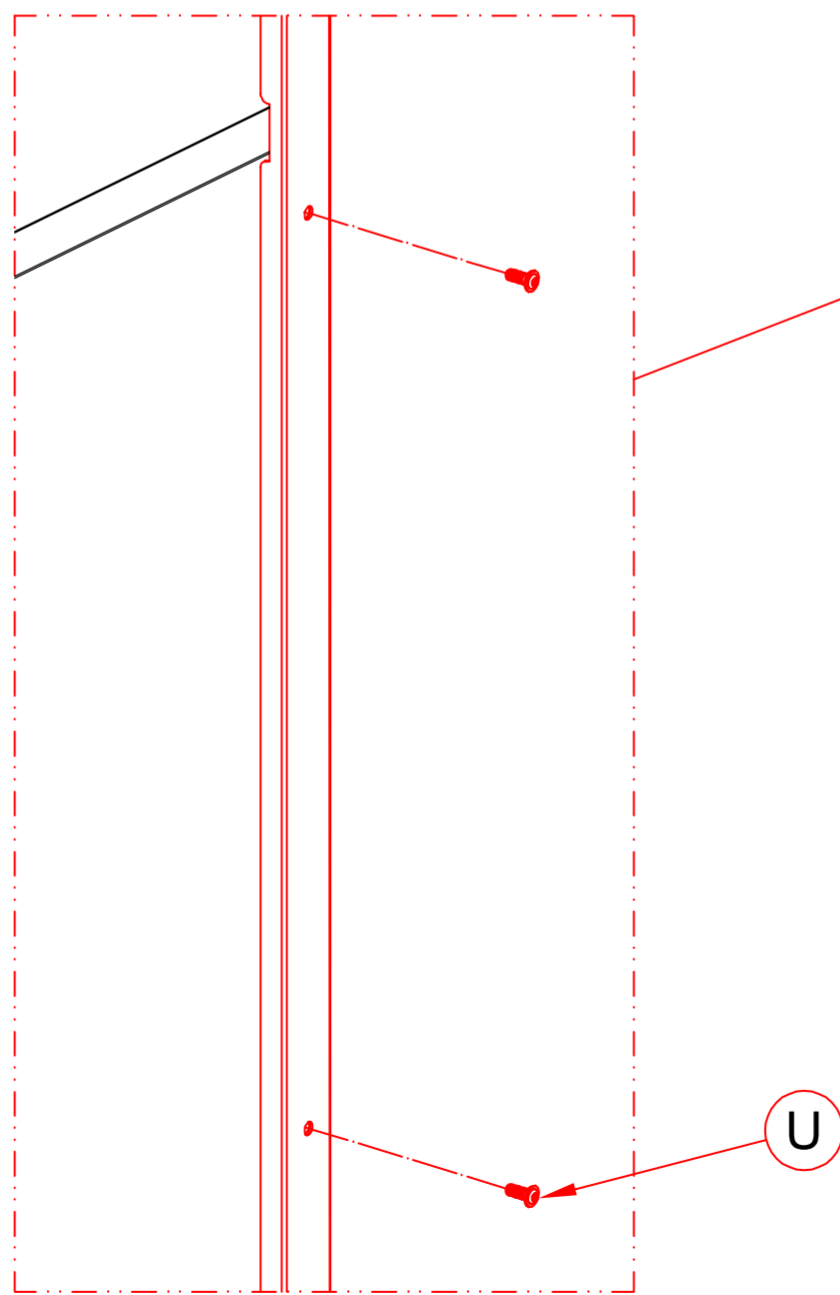
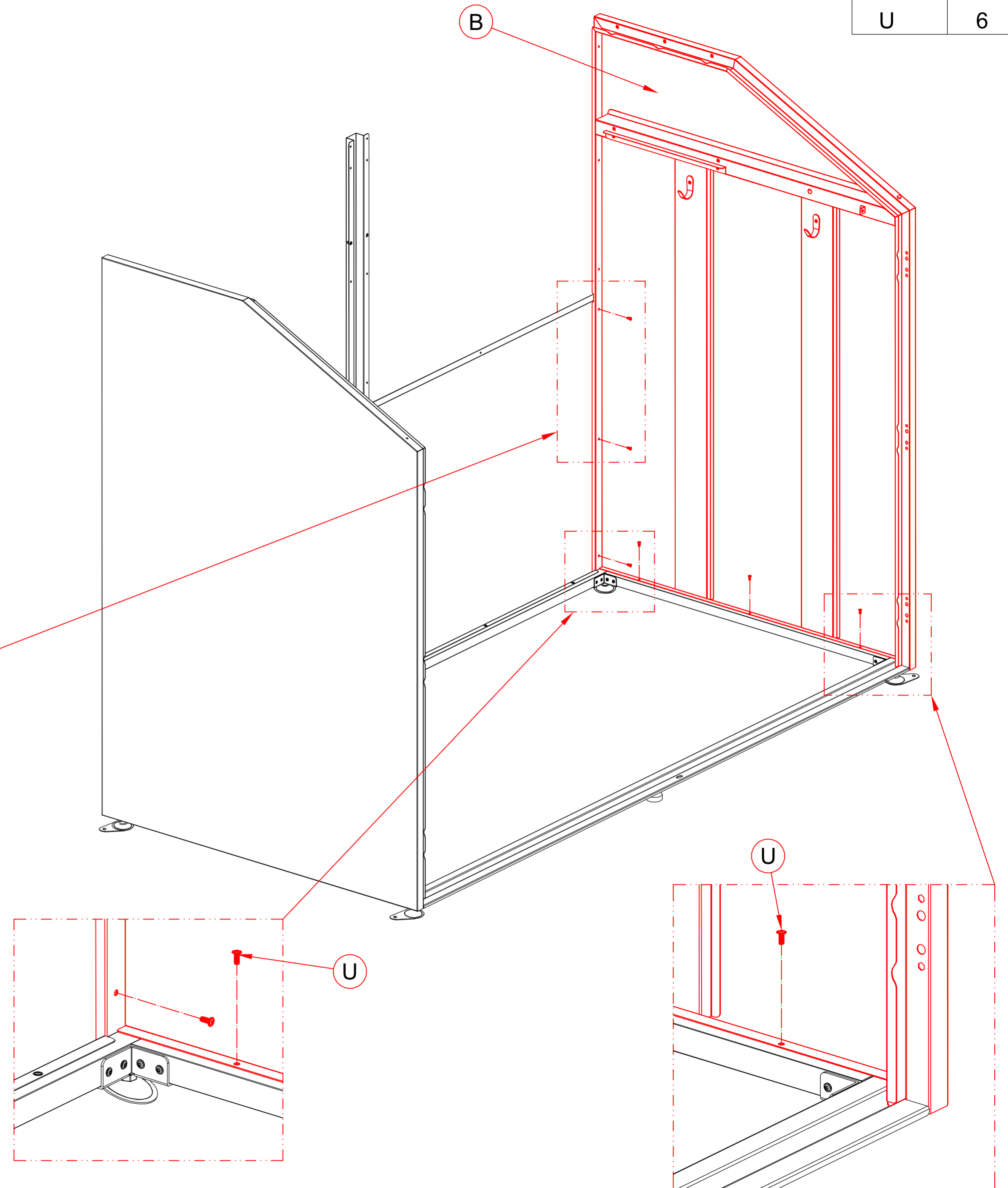
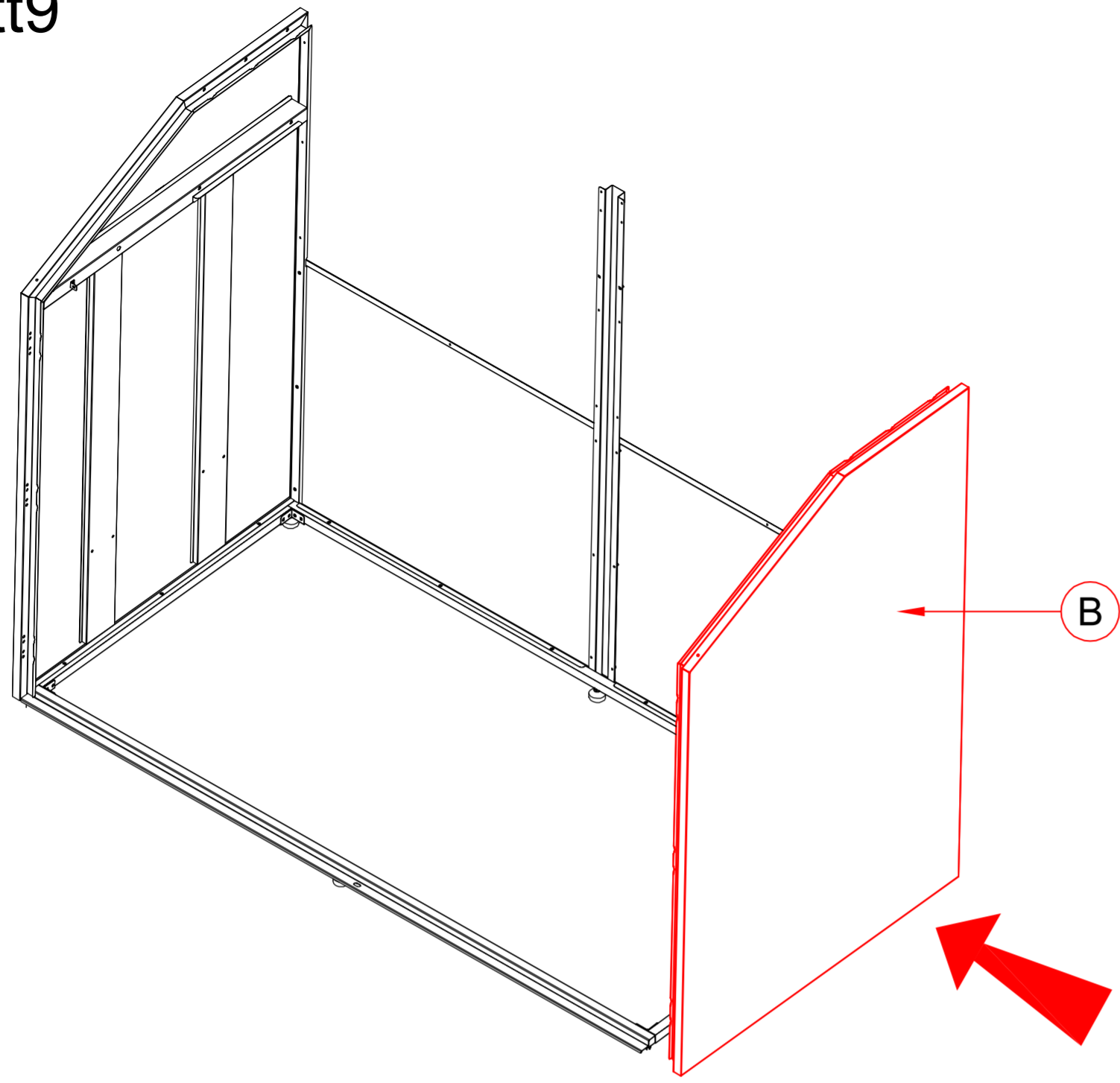

Schritt 10

ITEM	Qty
C	1
U	5

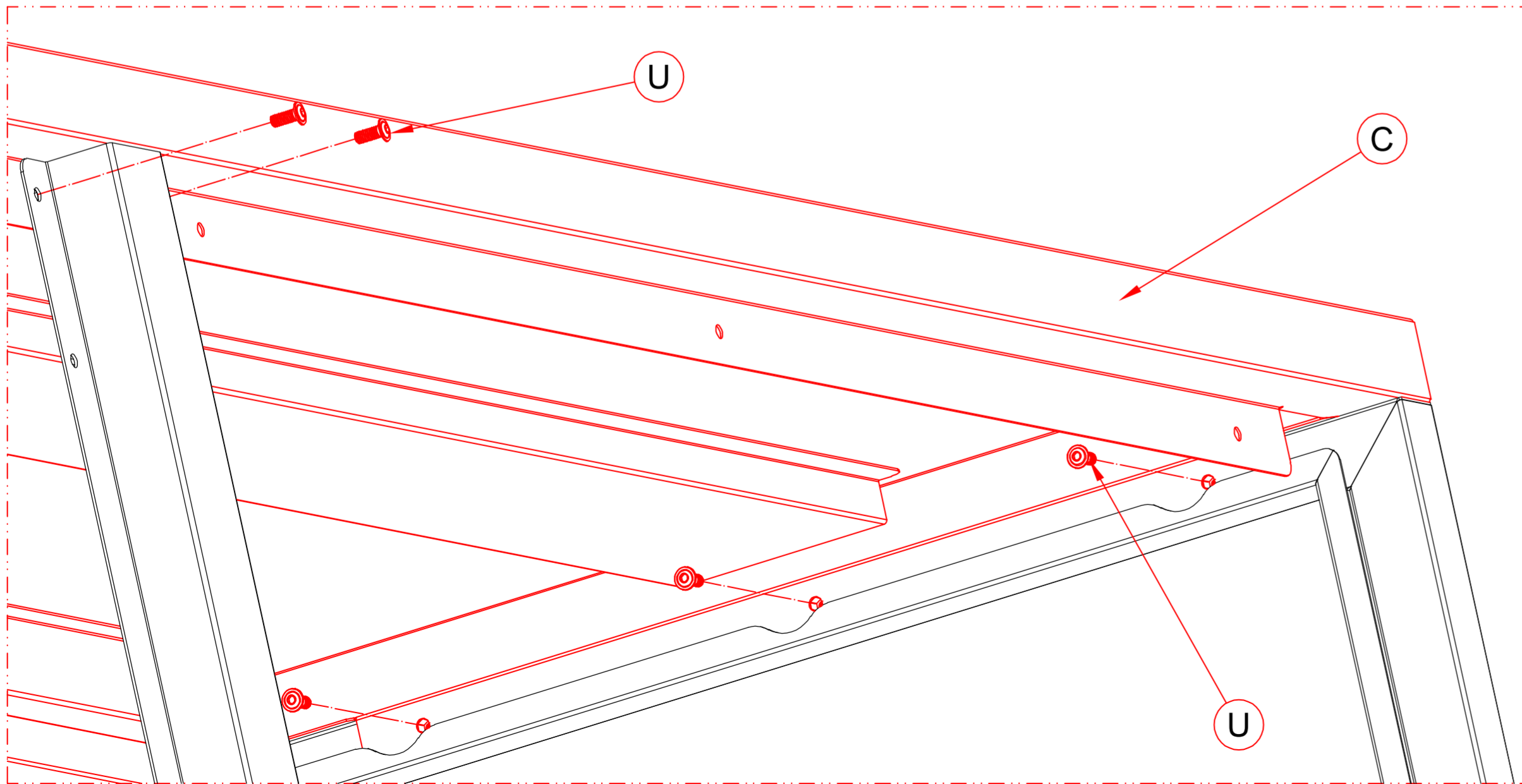
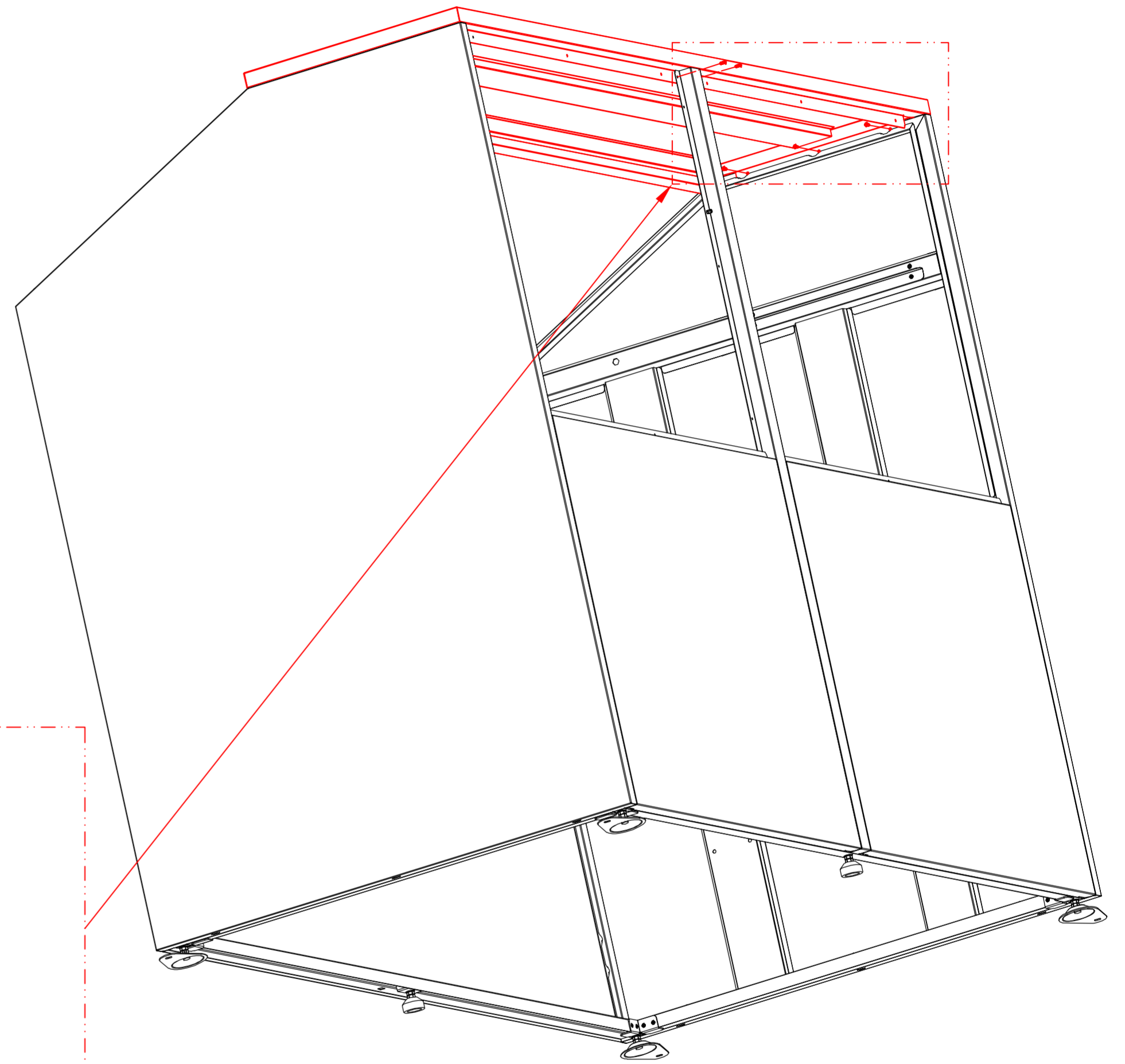
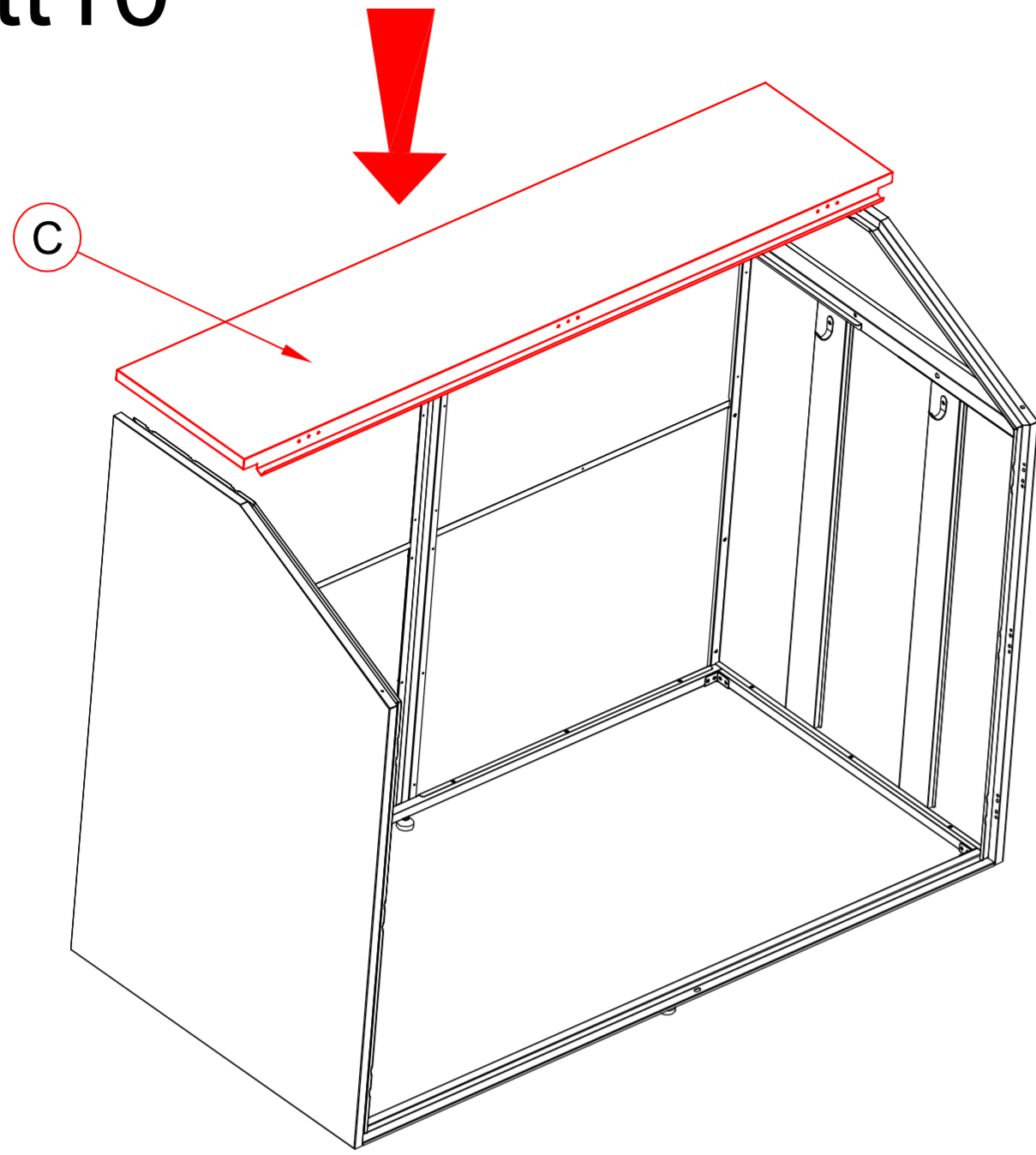

Schritt 11

ITEM	Qty
U	3

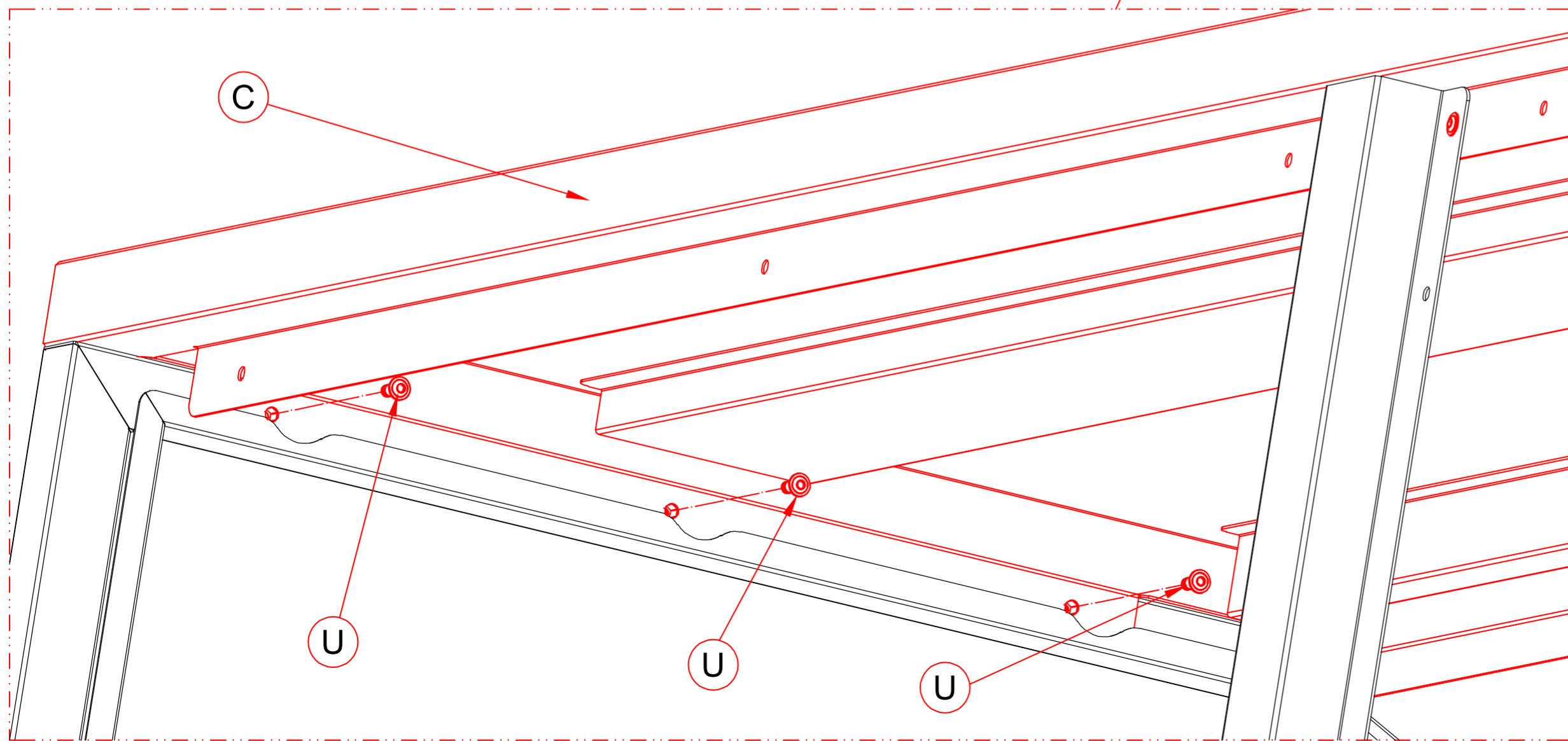
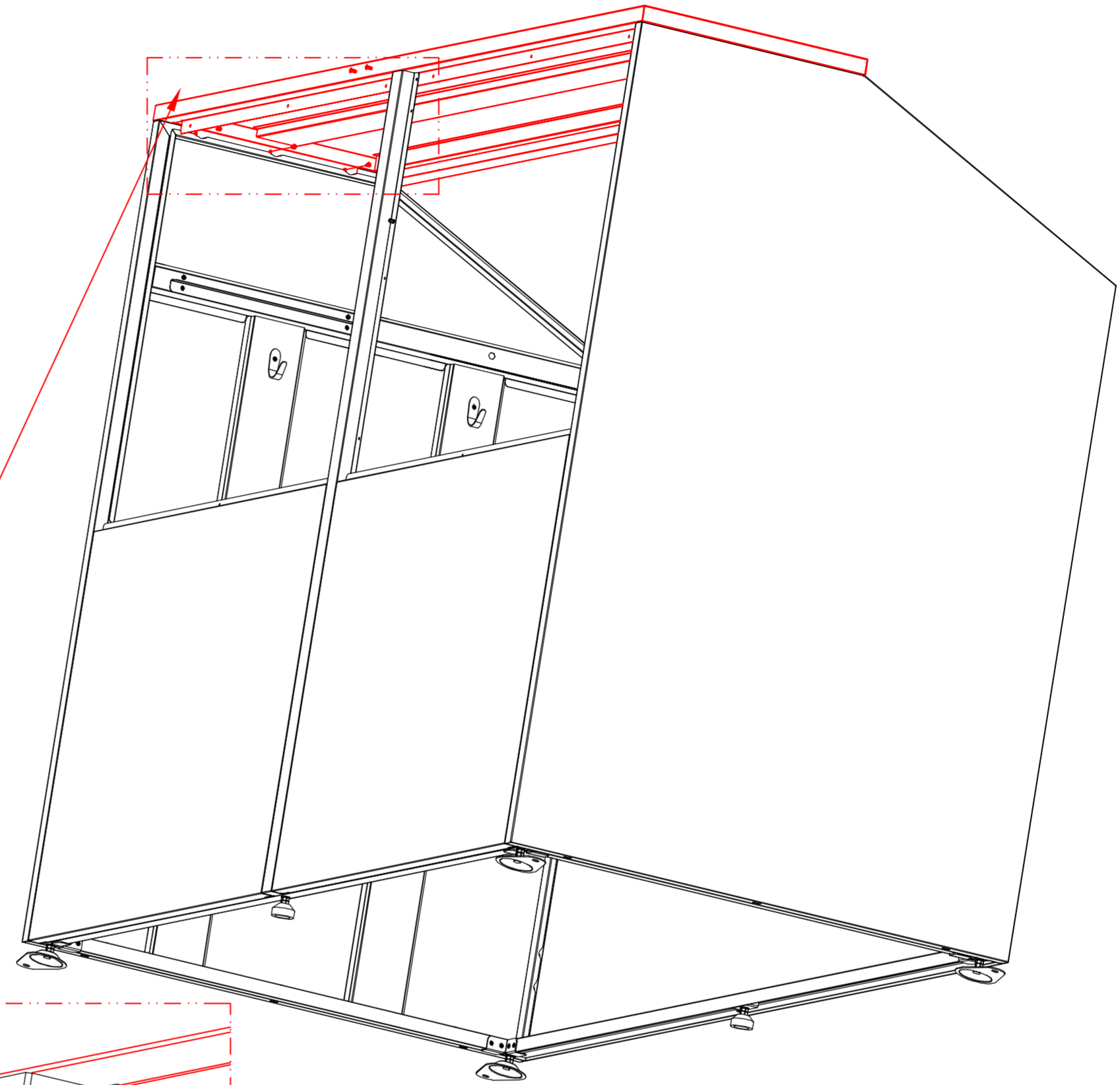
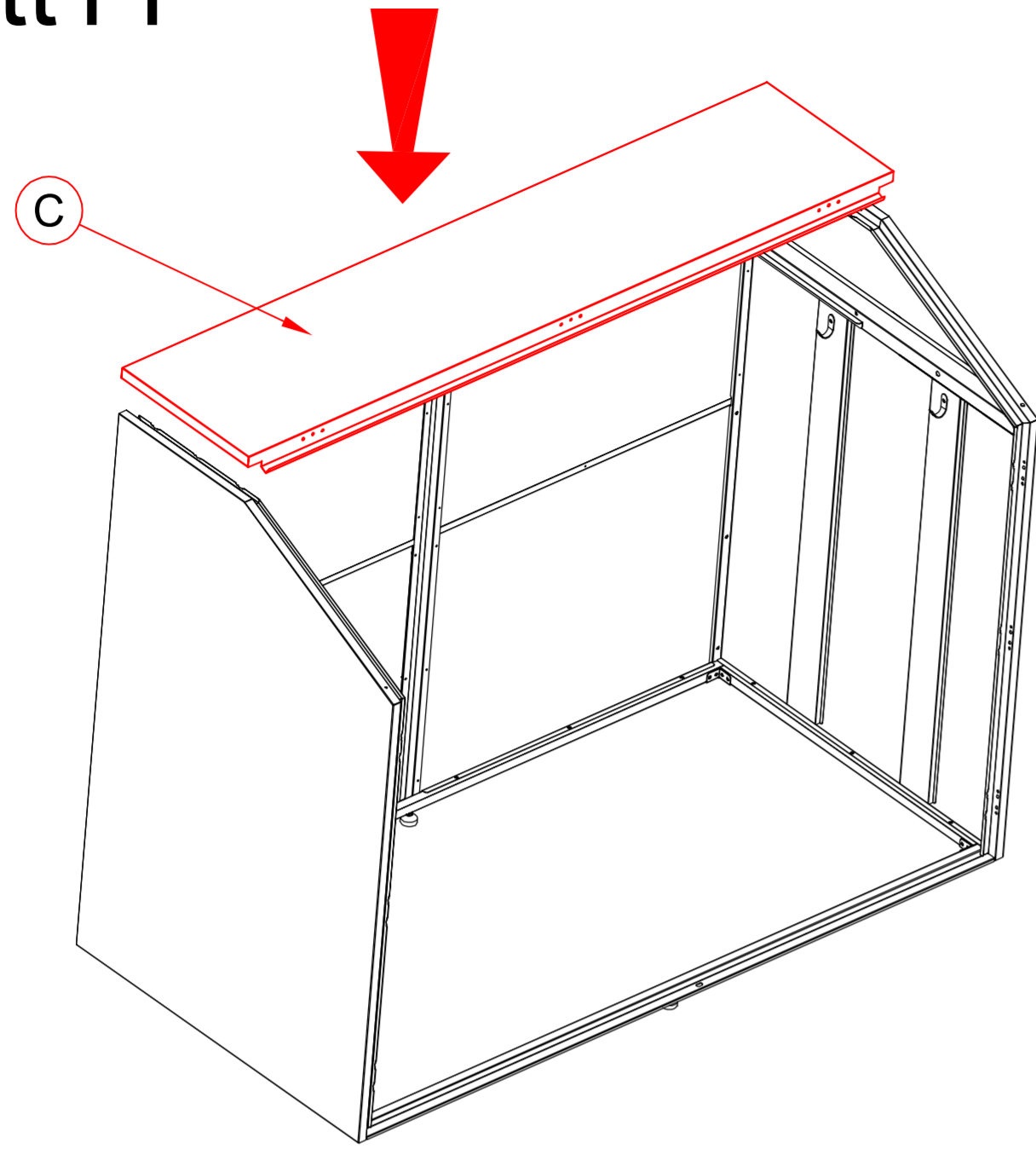

Schritt 12

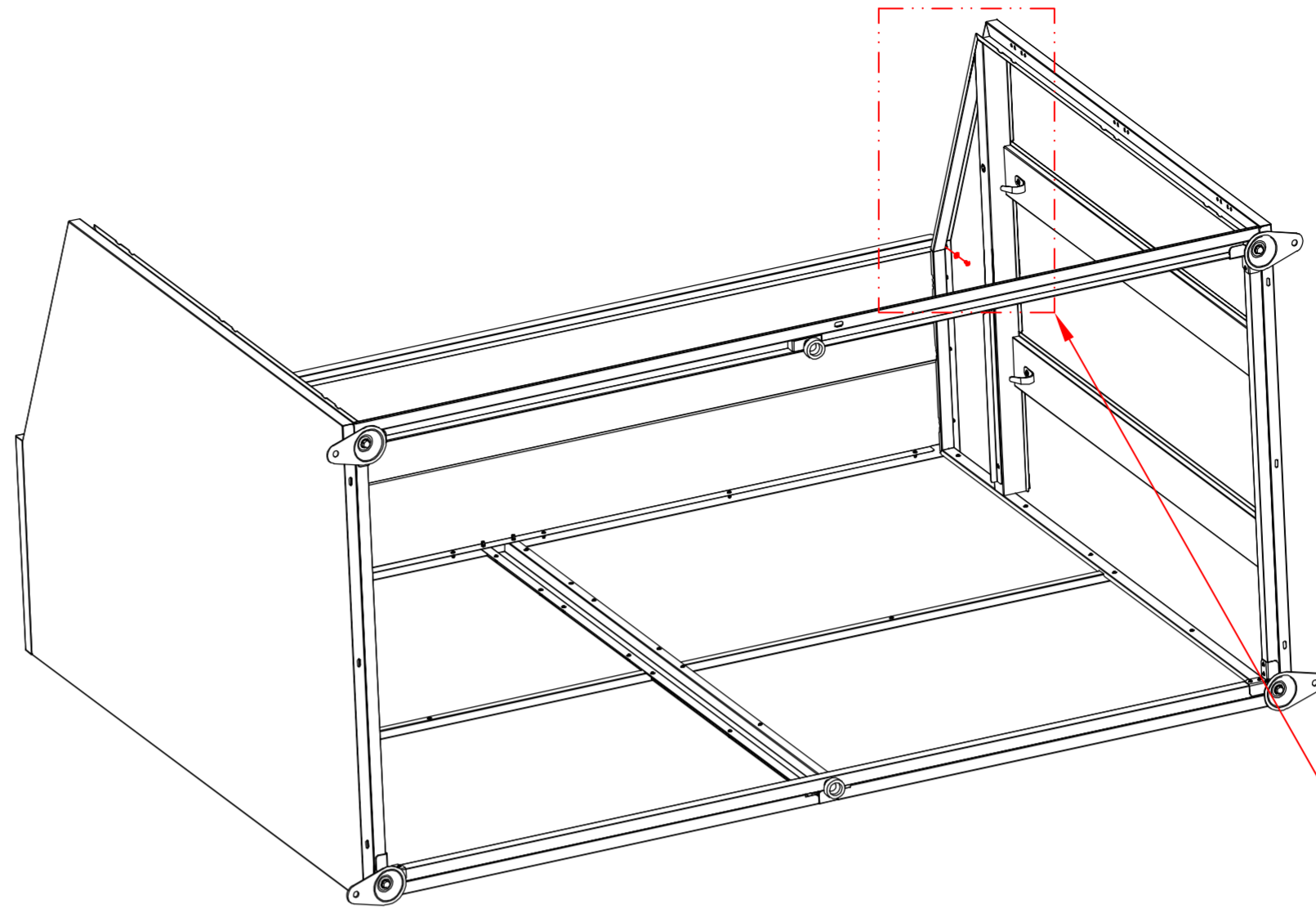
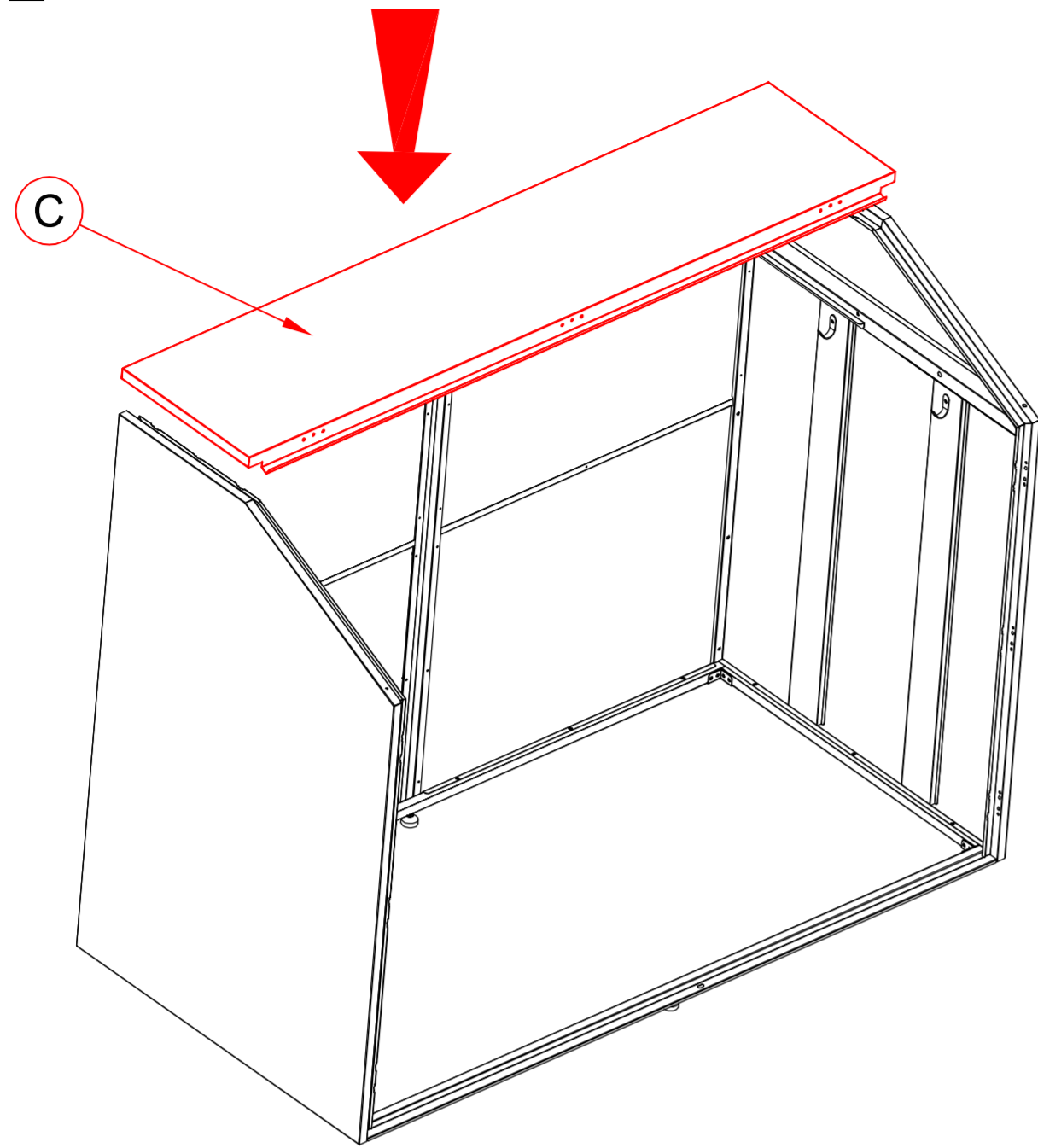

ITEM	Qty
9	2
U	2

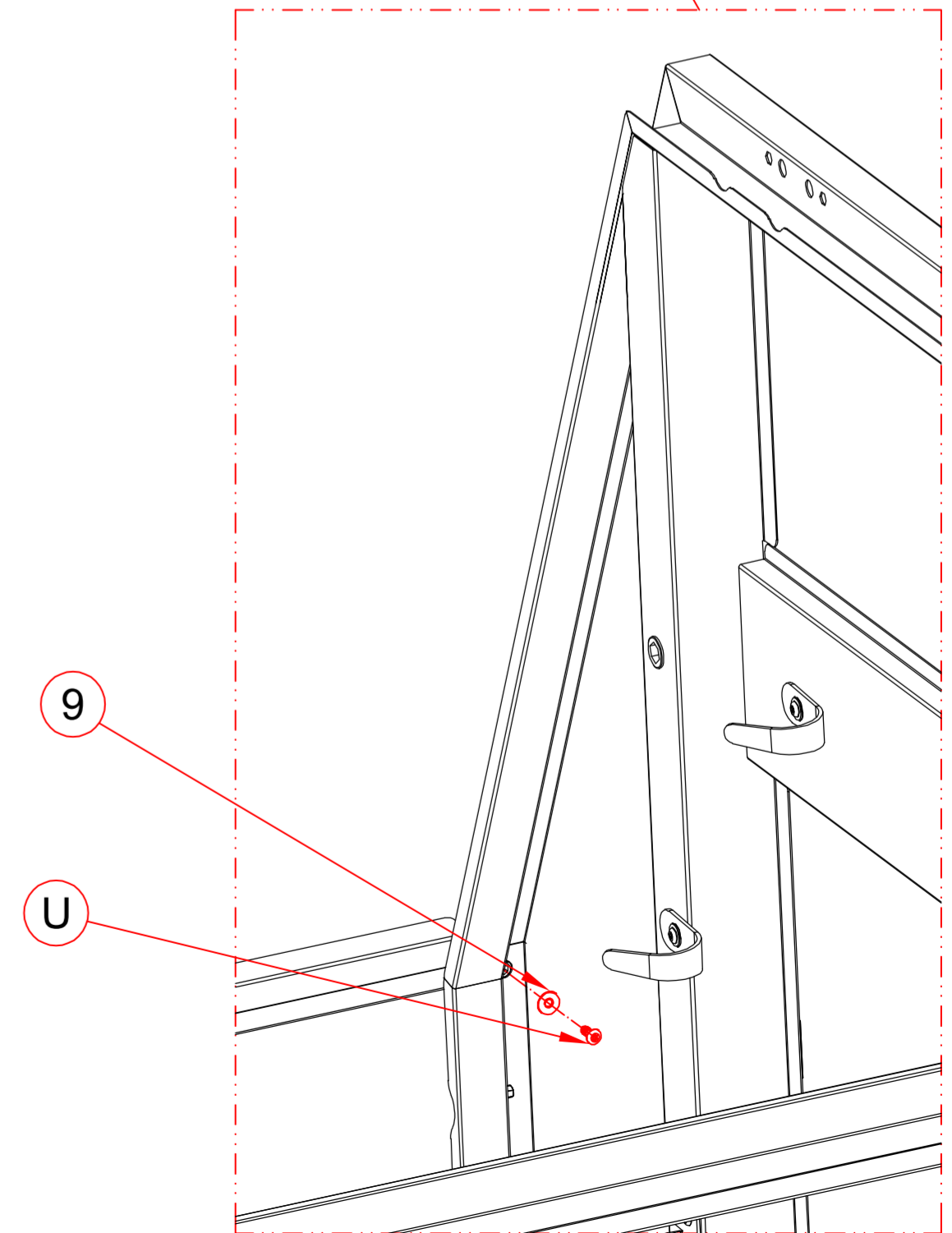
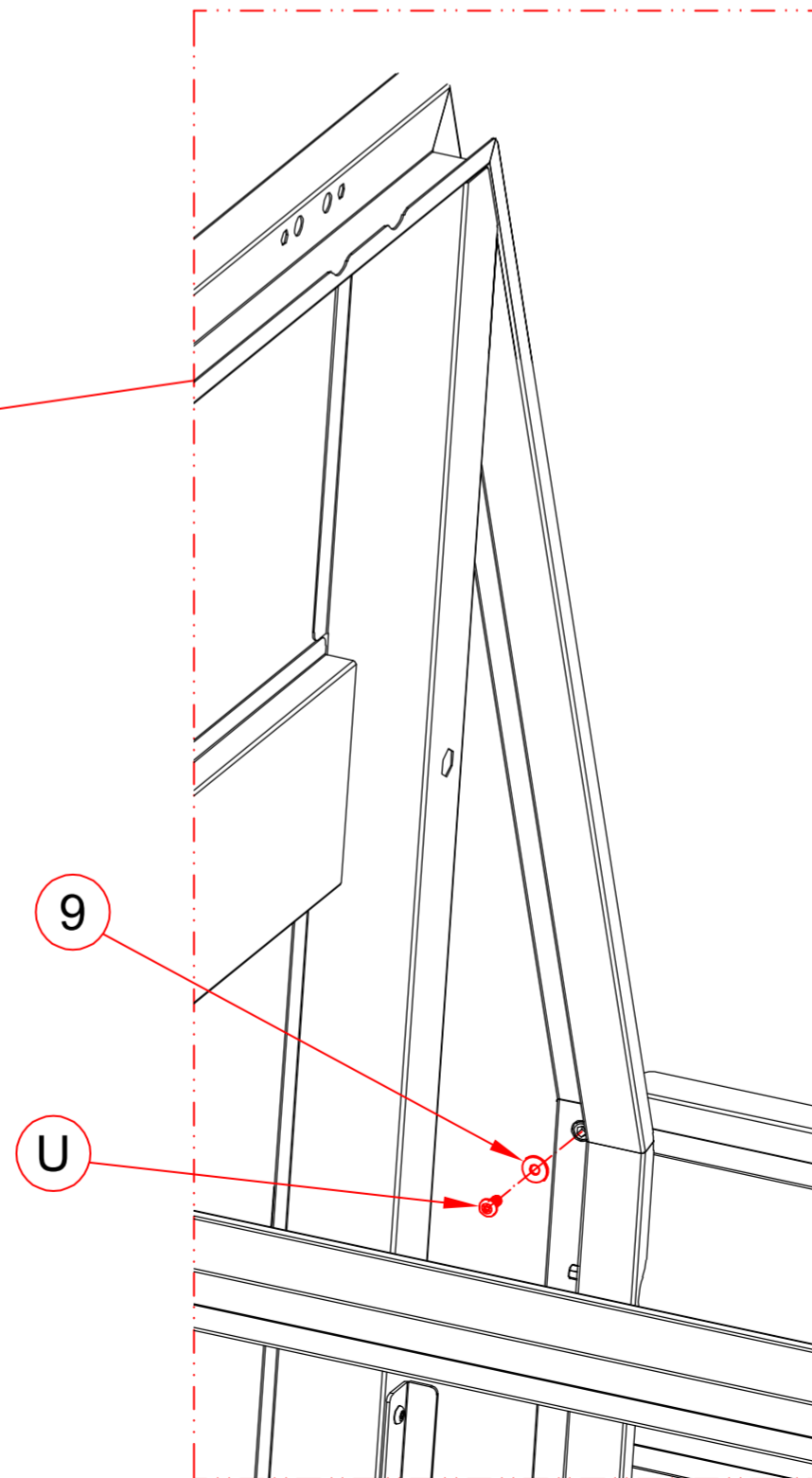
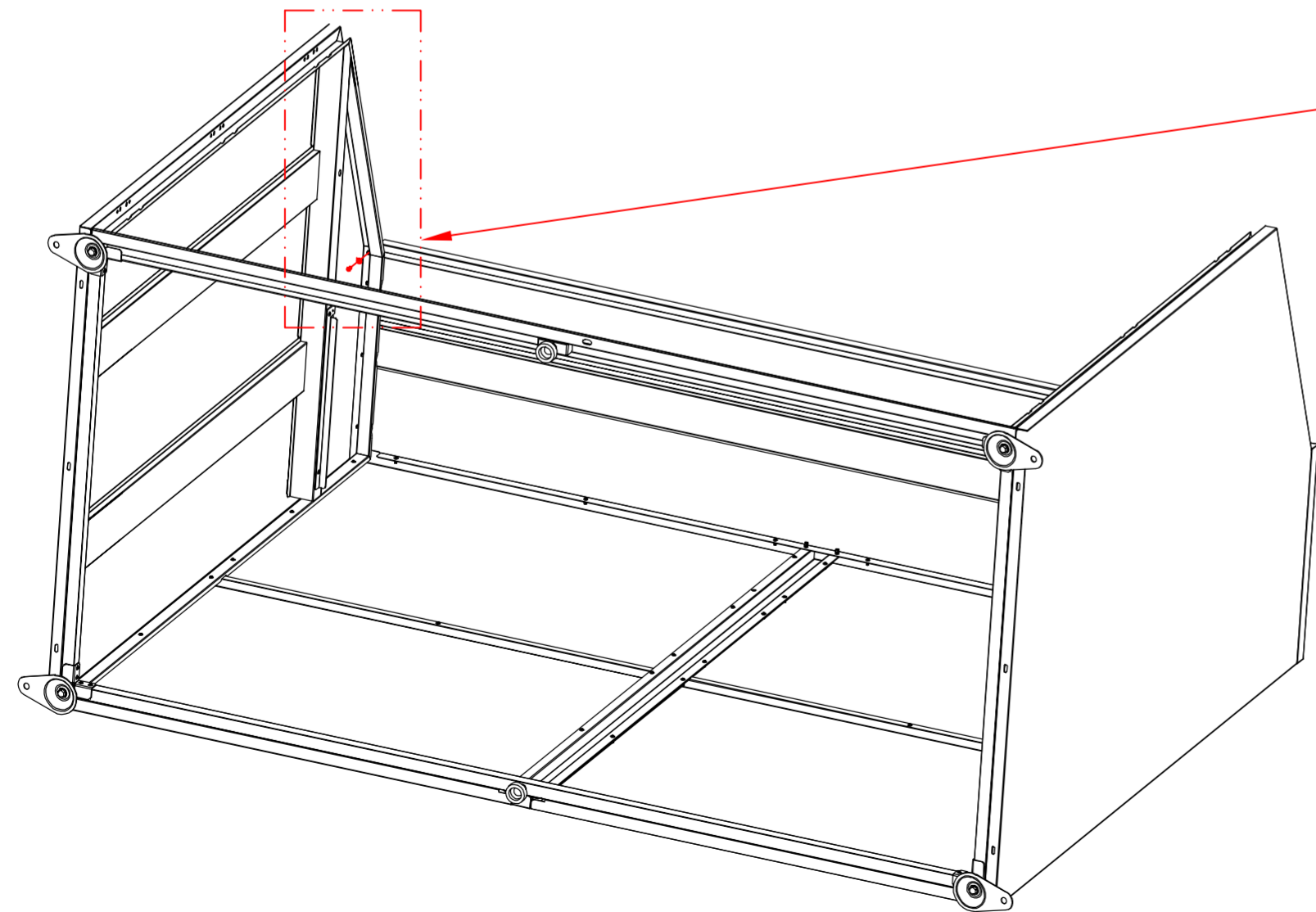

Schritt 13

ITEM	Qty
E	2
U	10

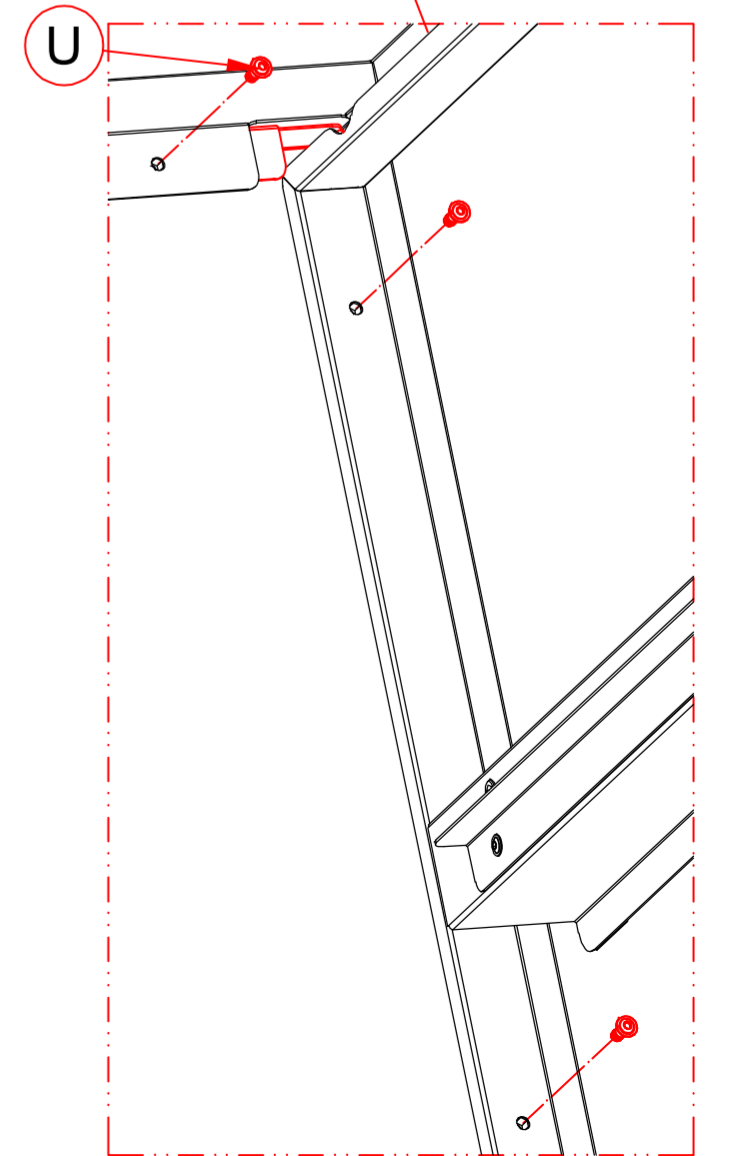
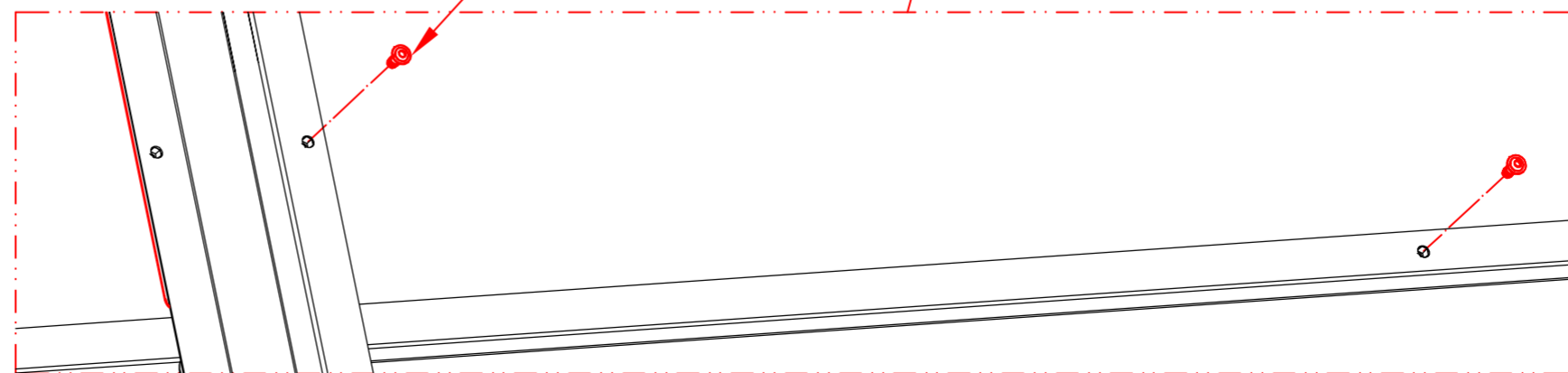
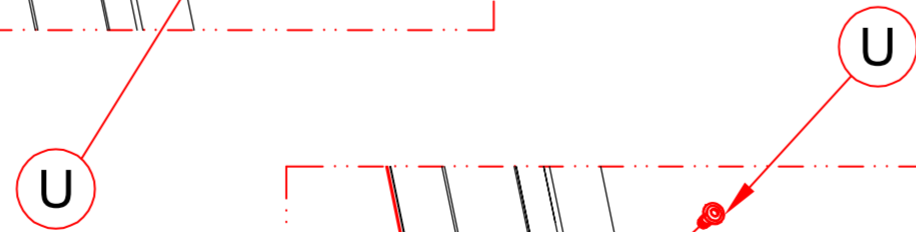
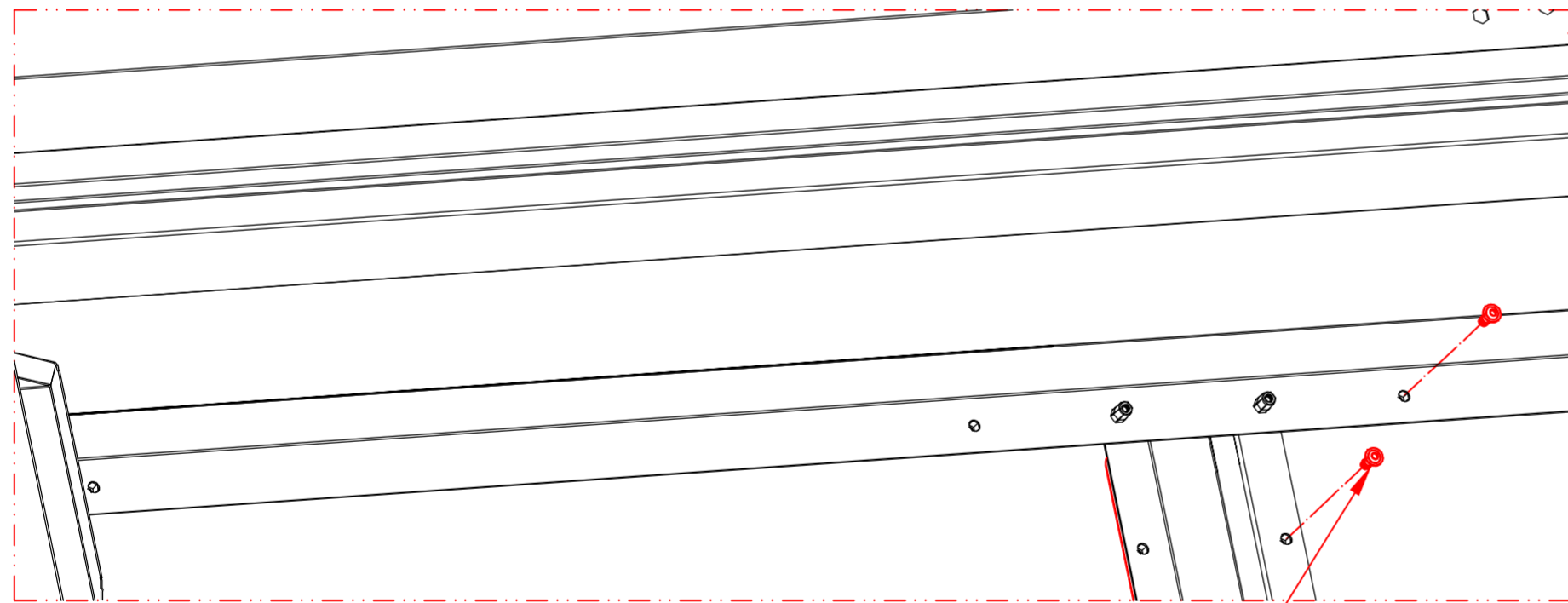
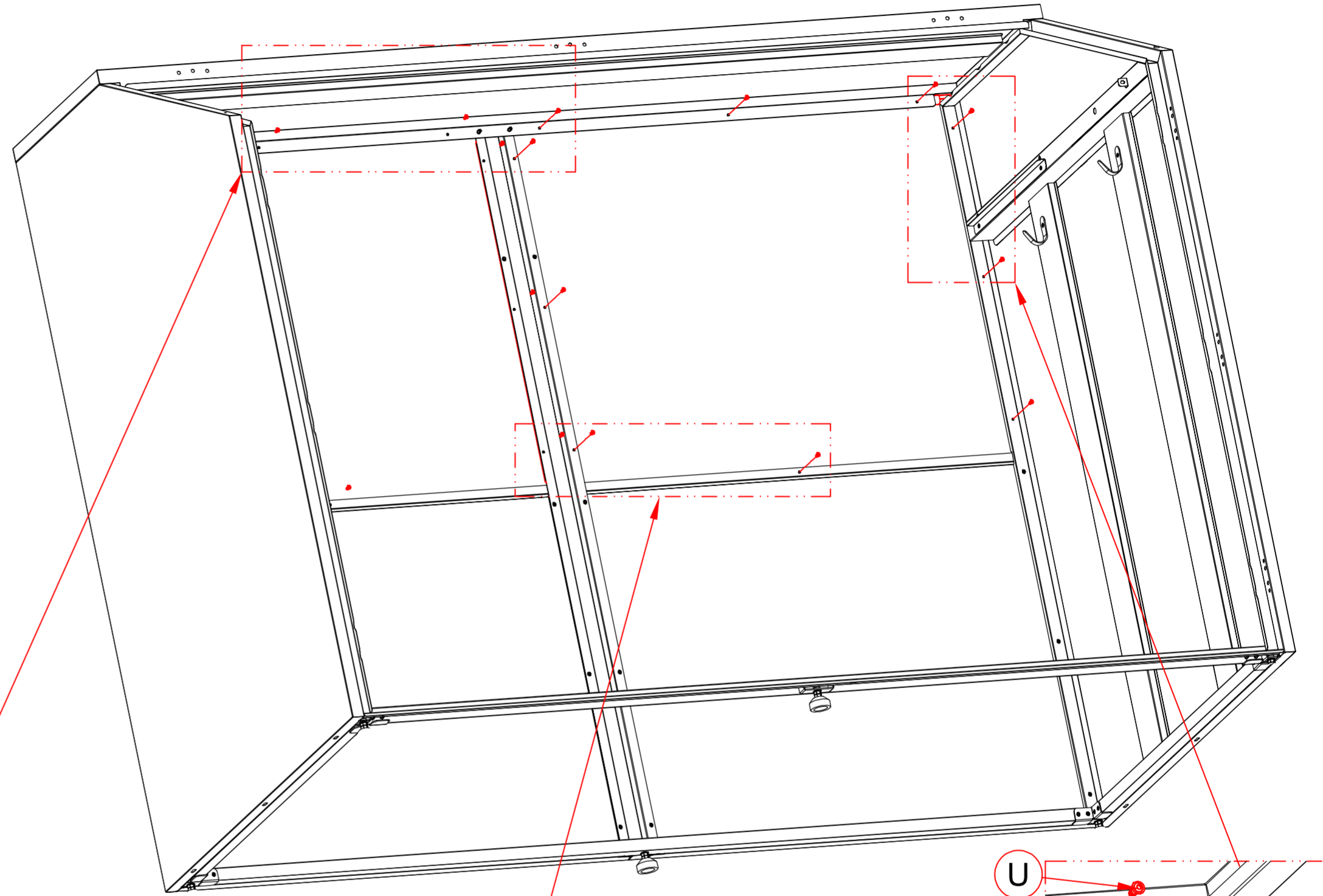
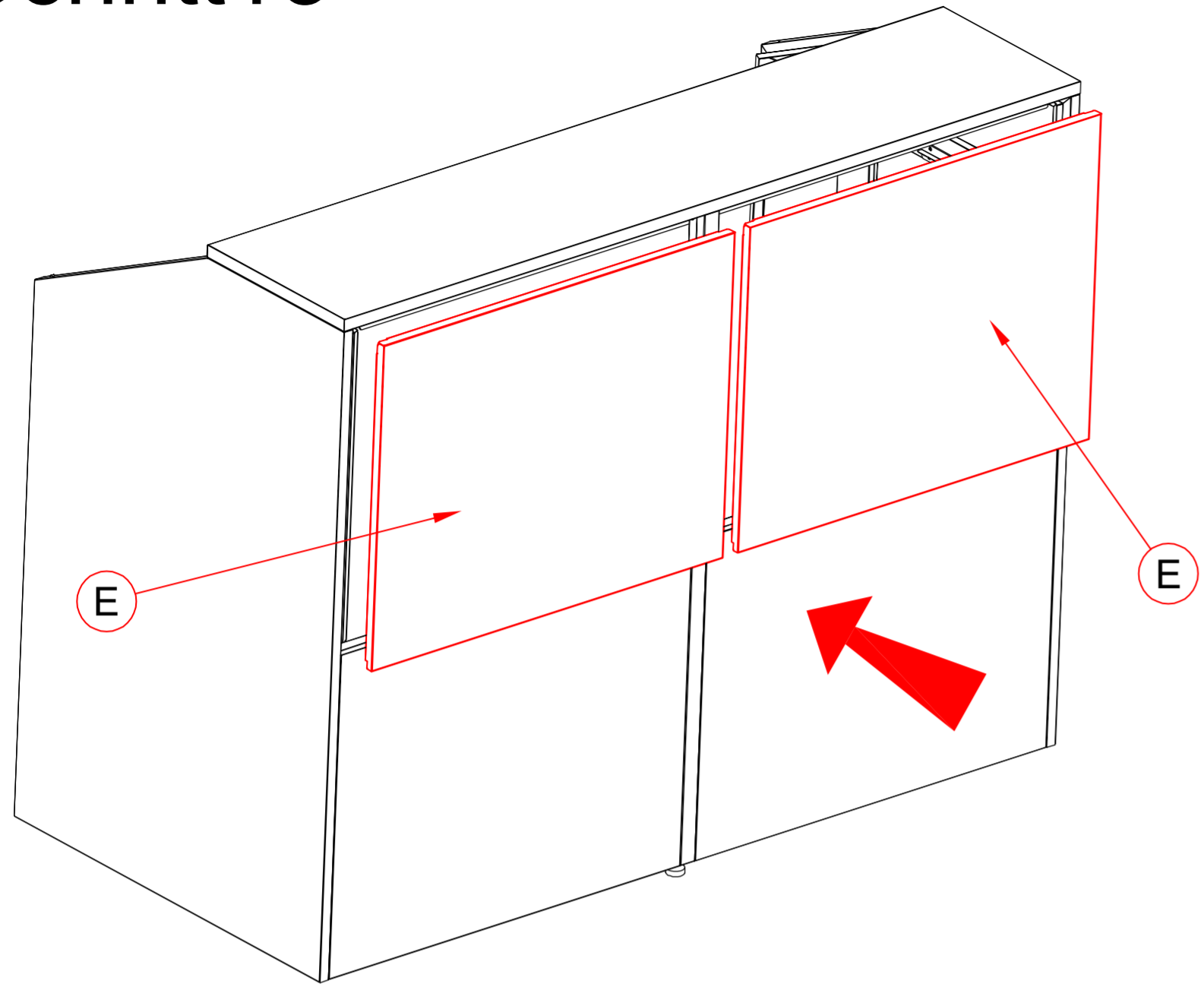

Schritt 14

ITEM	Qty
U	10

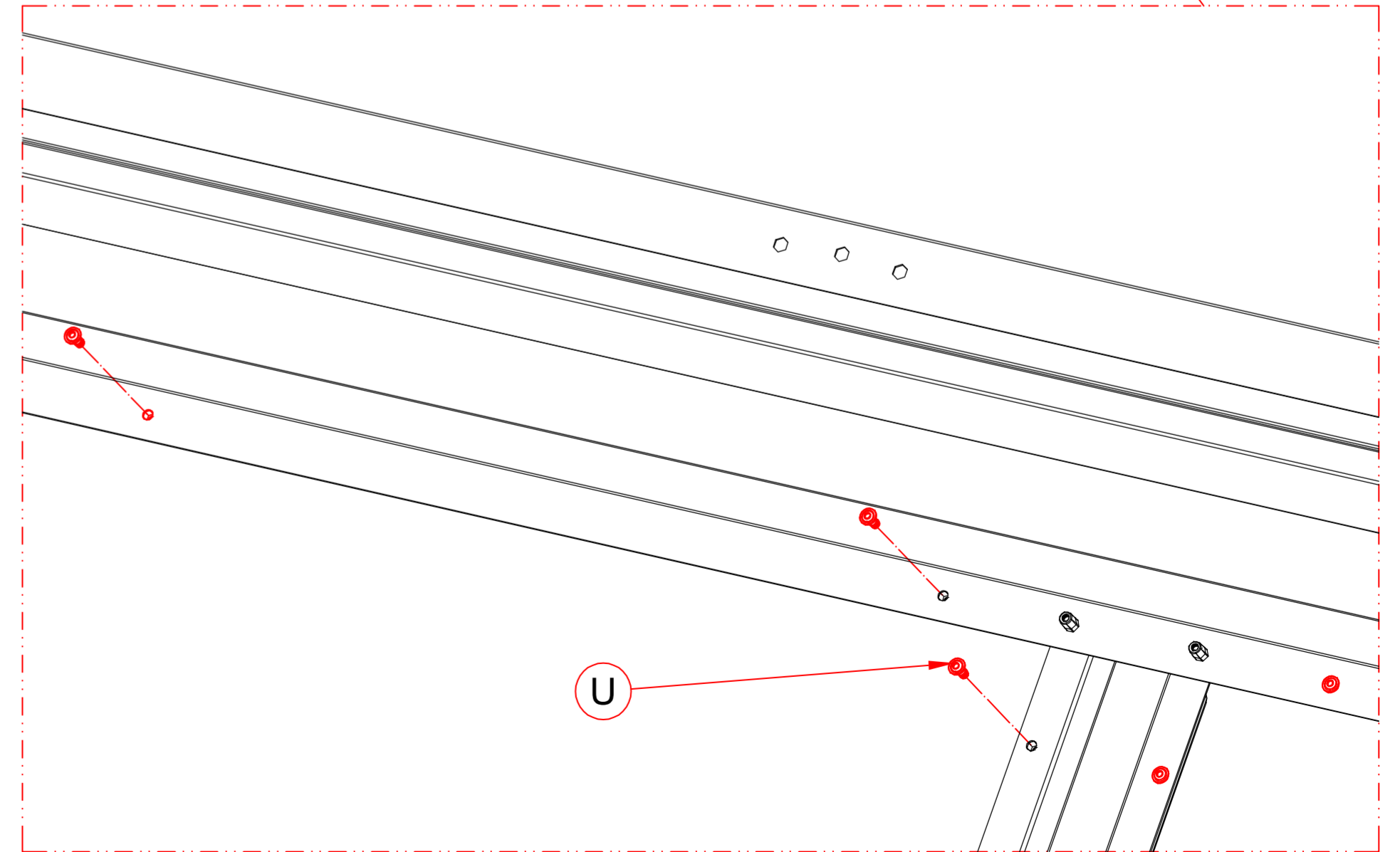
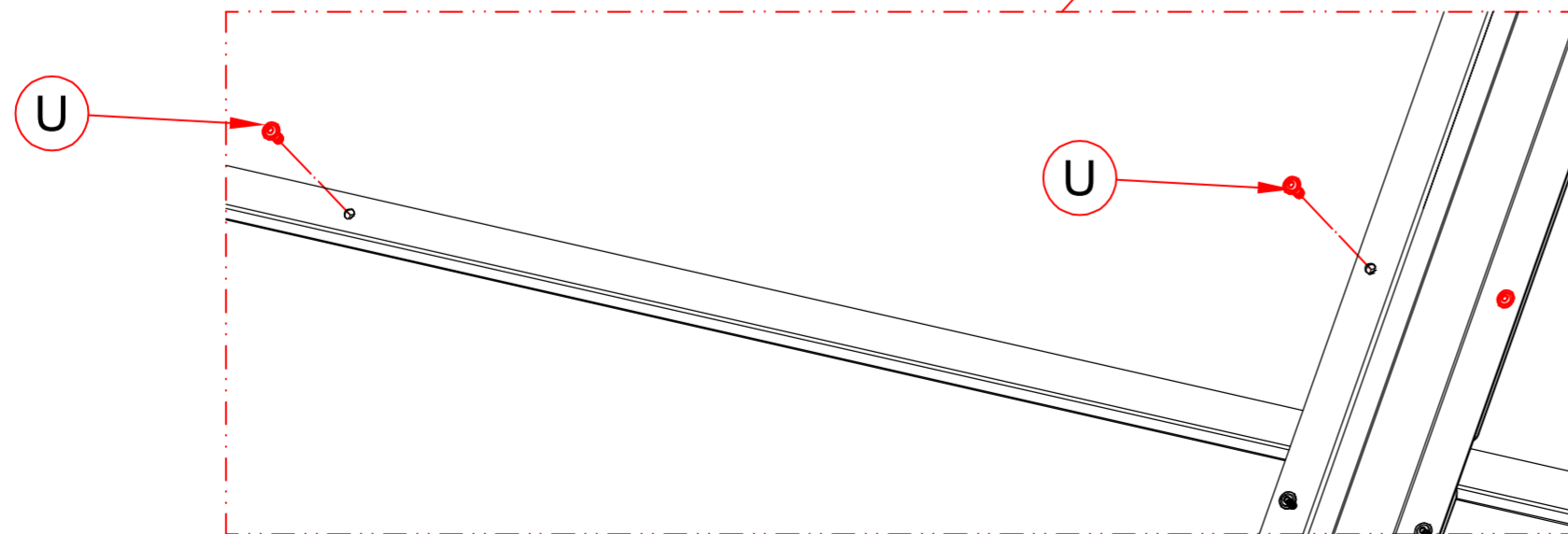
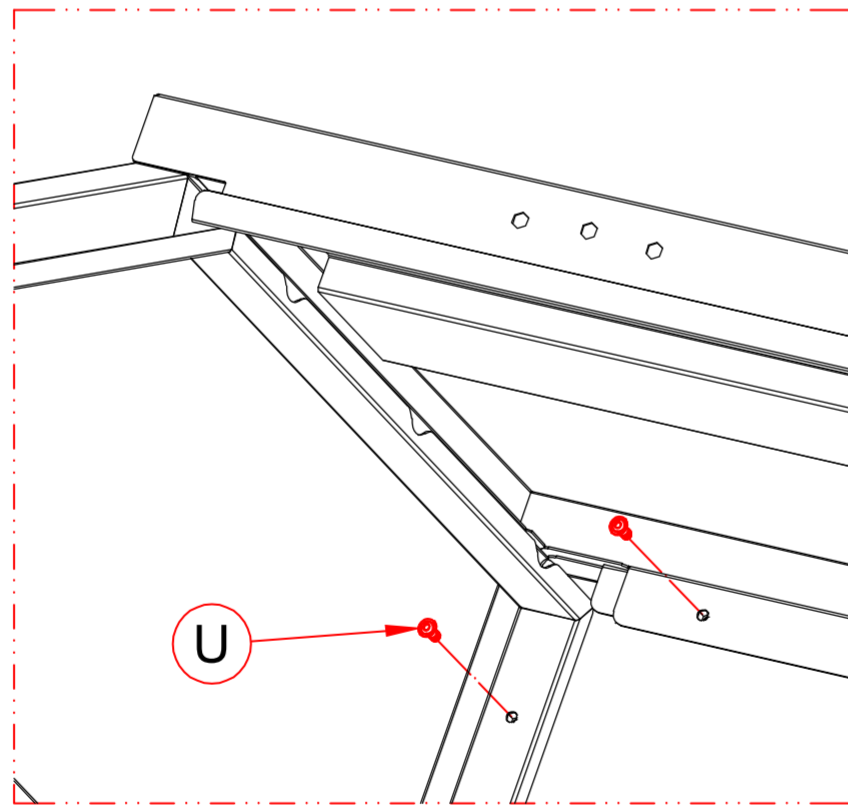
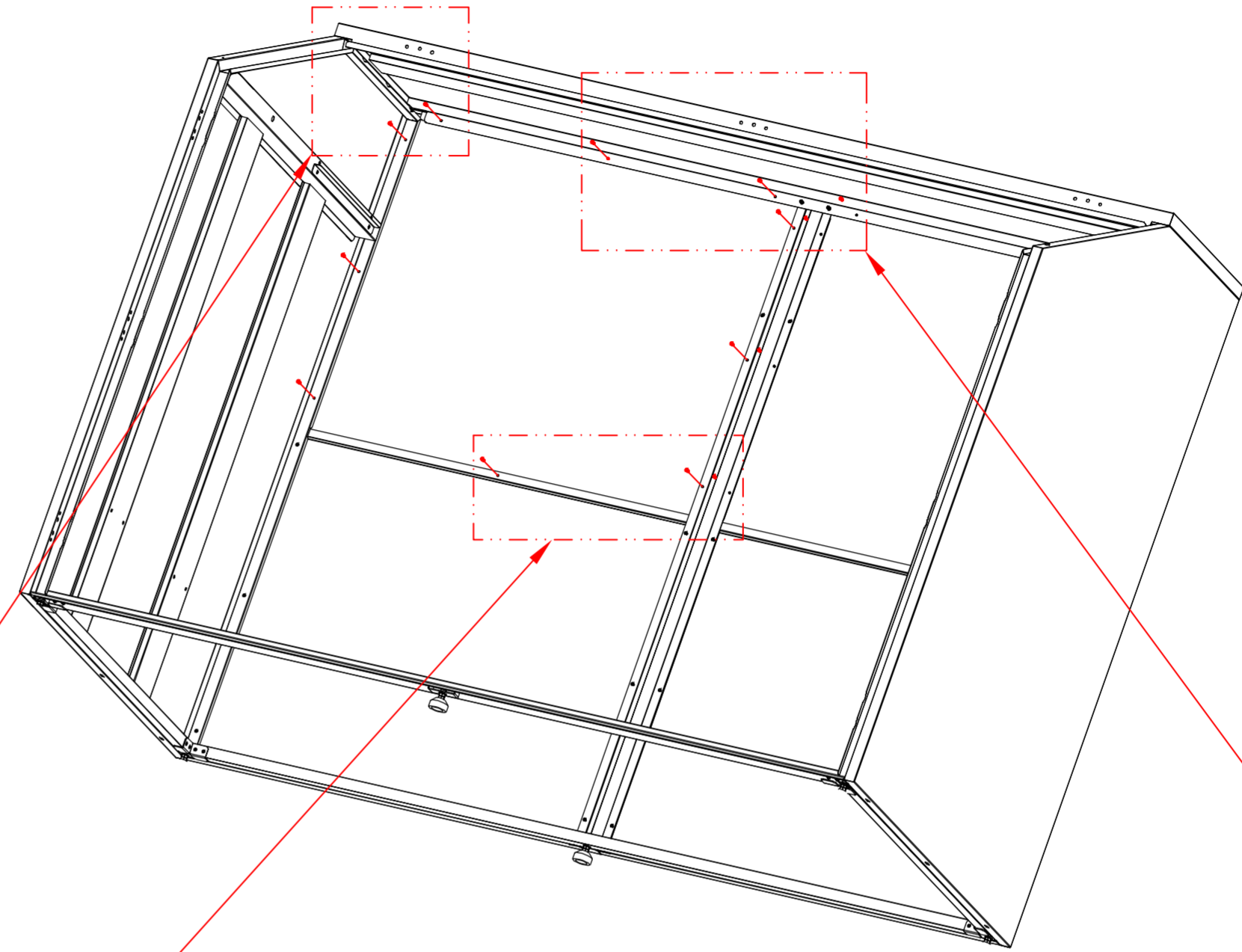
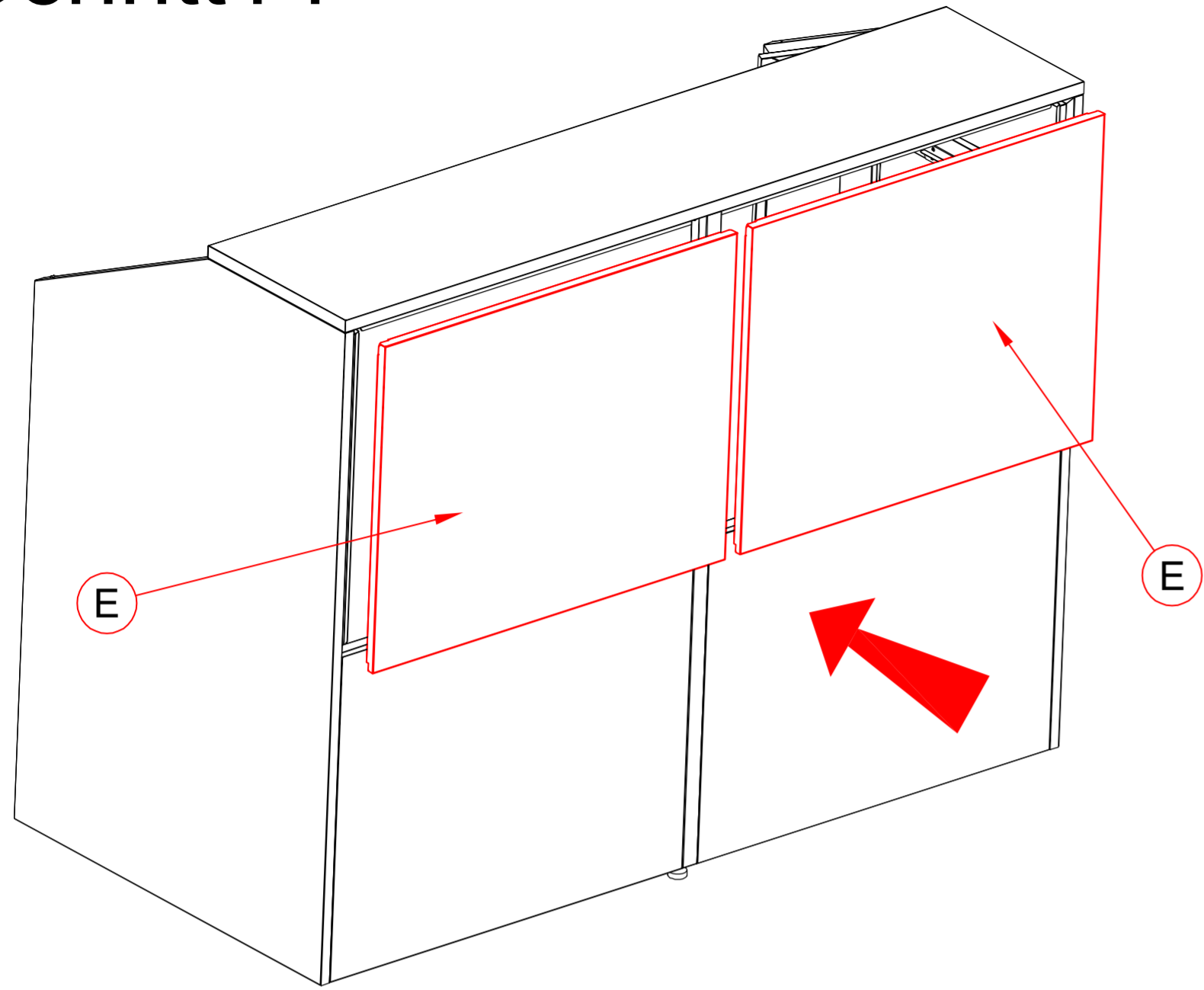

Schritt 15

Dieser Bereich hat eine Vorkompression, um dem Herabhängen der Tür zu widerstehen, so dass Sie möglicherweise etwas mehr Kraft aufwenden müssen, um sie einzubauen.

ITEM	Qty
K	1
U	6

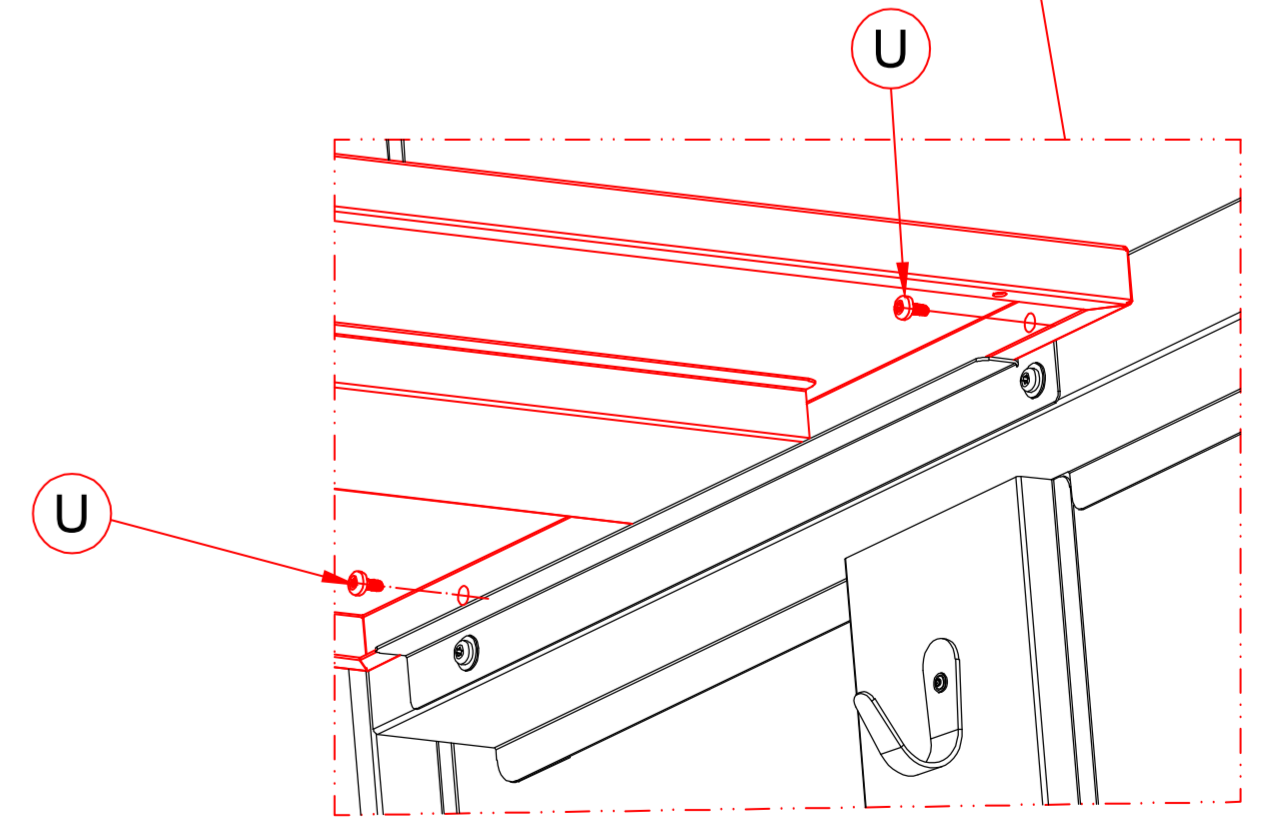
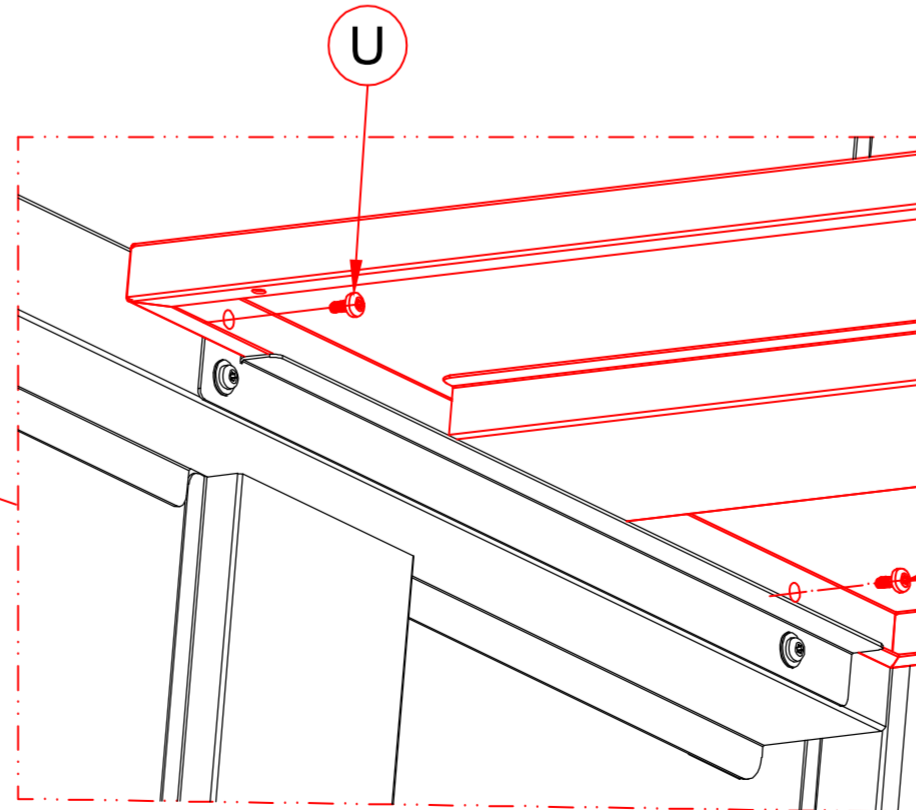
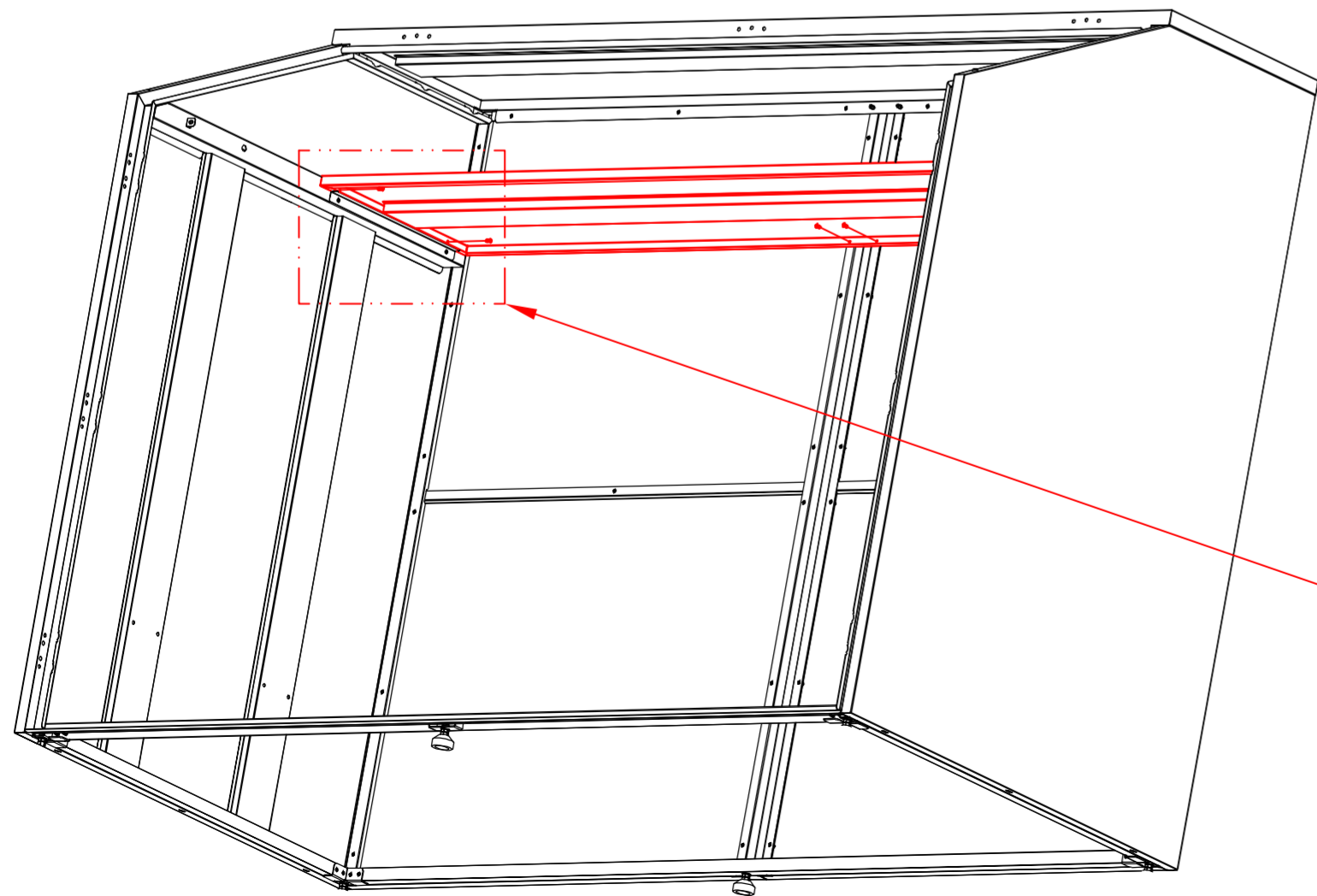
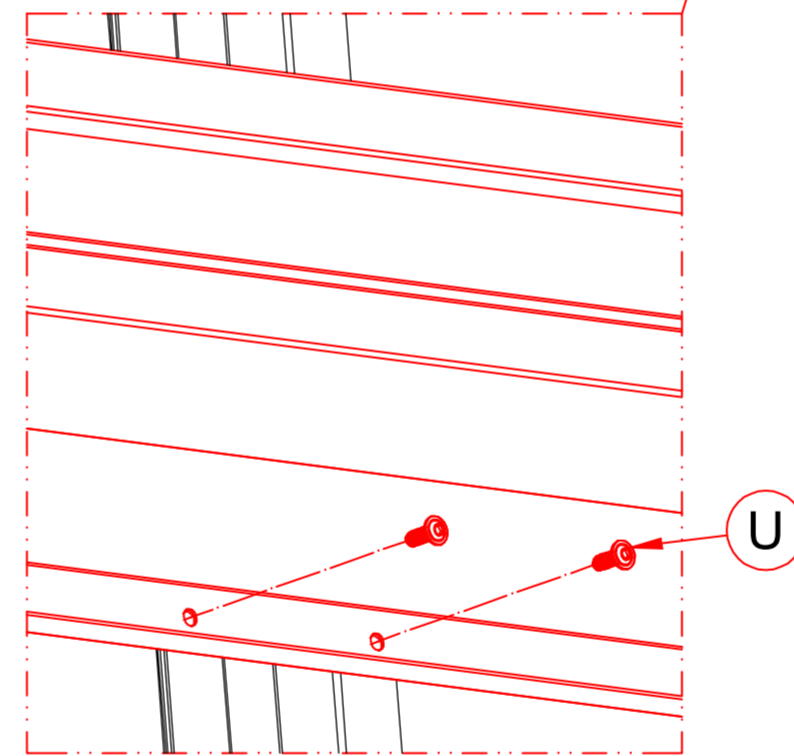
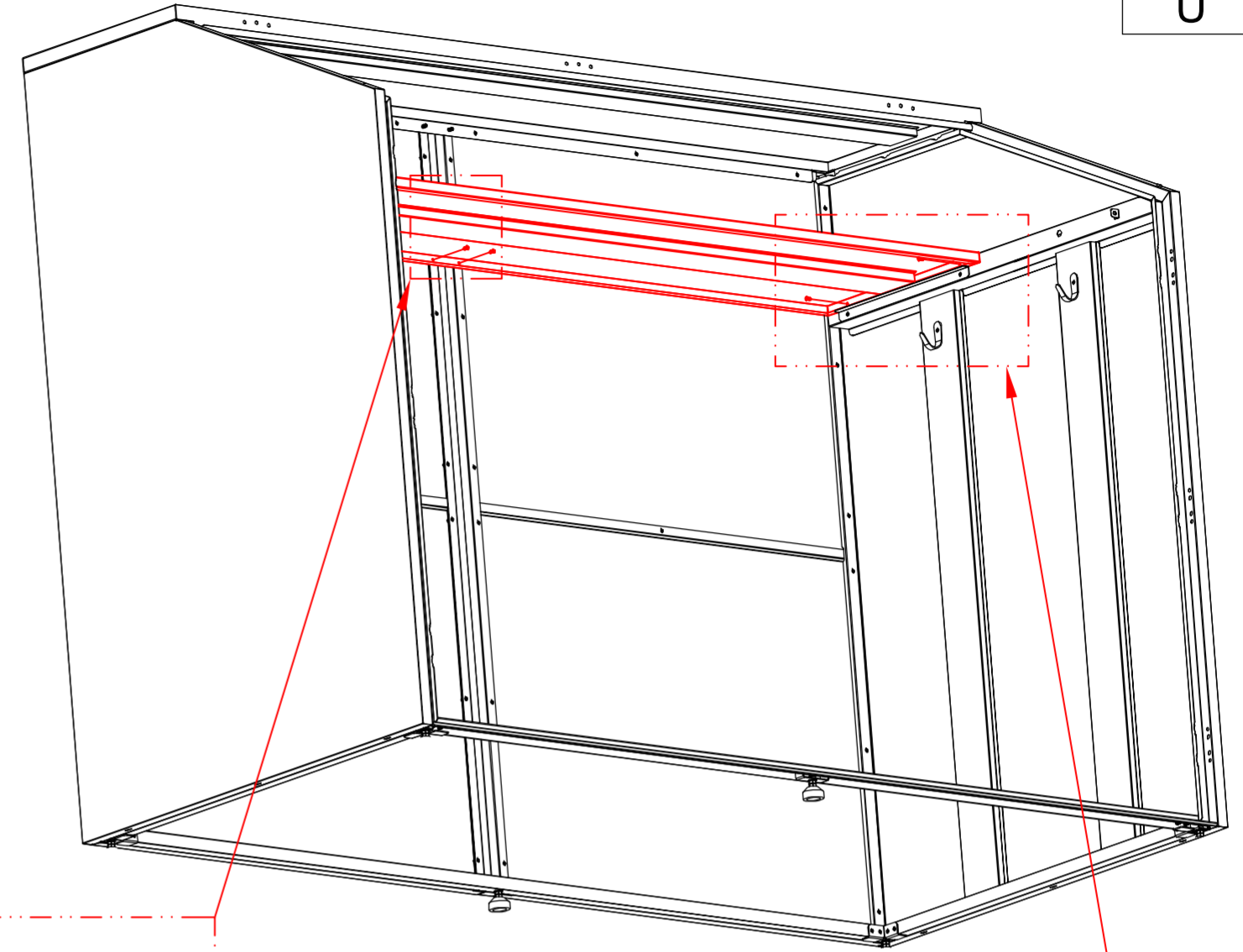
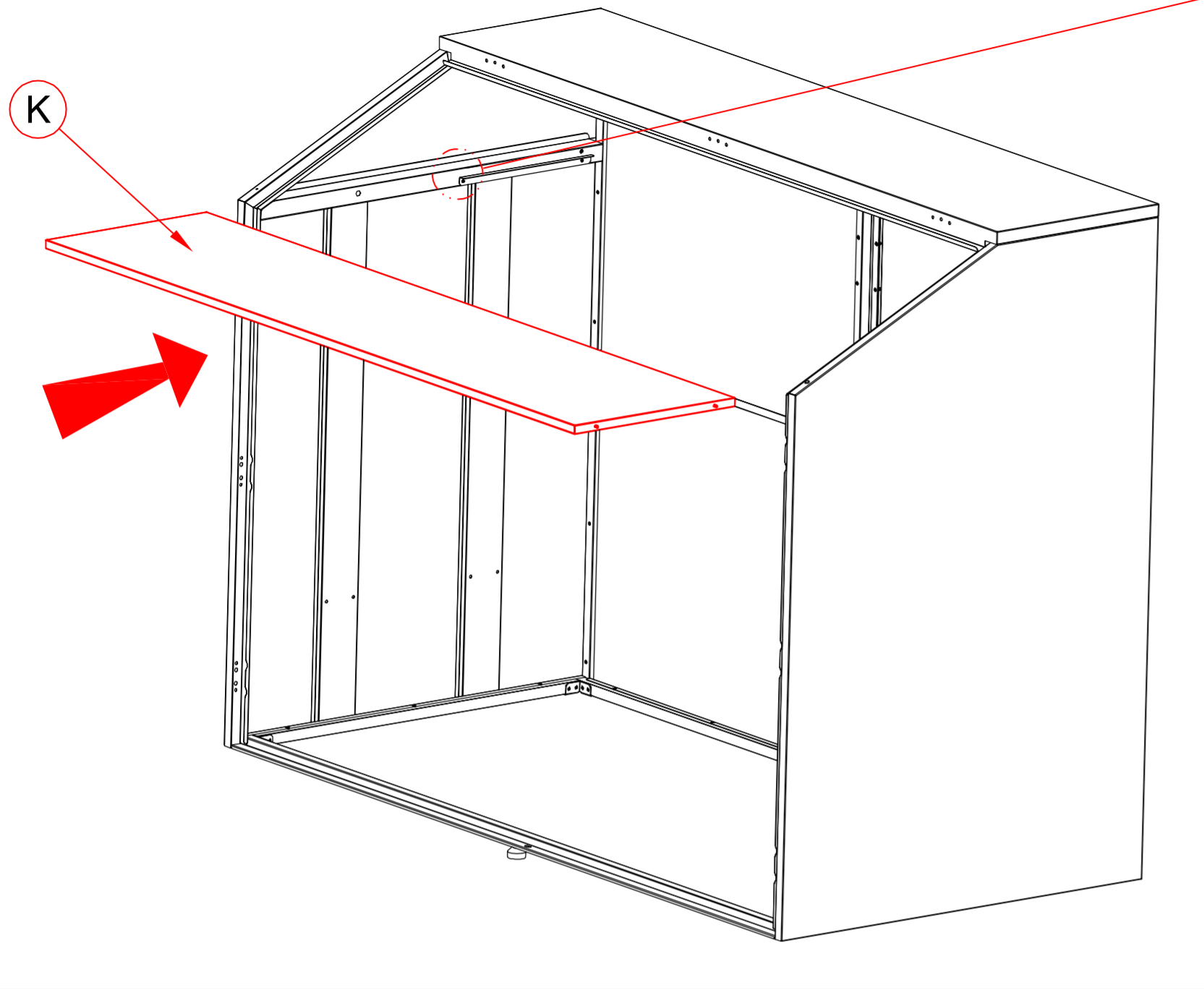

Schritt 16

ITEM	Qty
D	1
X	3
V	9
3	2
5	2
6	2

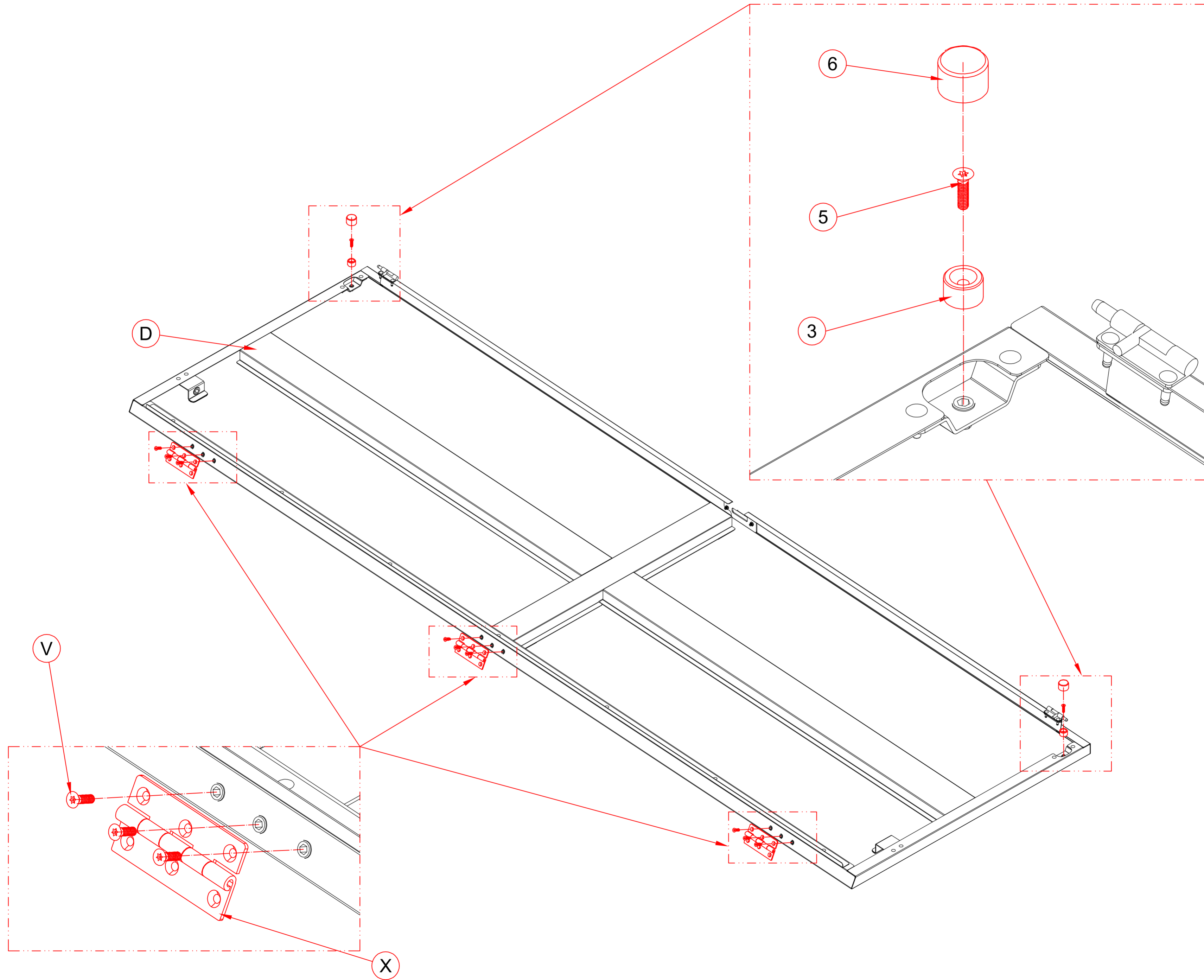

Schritt17

ITEM	Qty
D	1
R	1
T	2
2	2
10	2

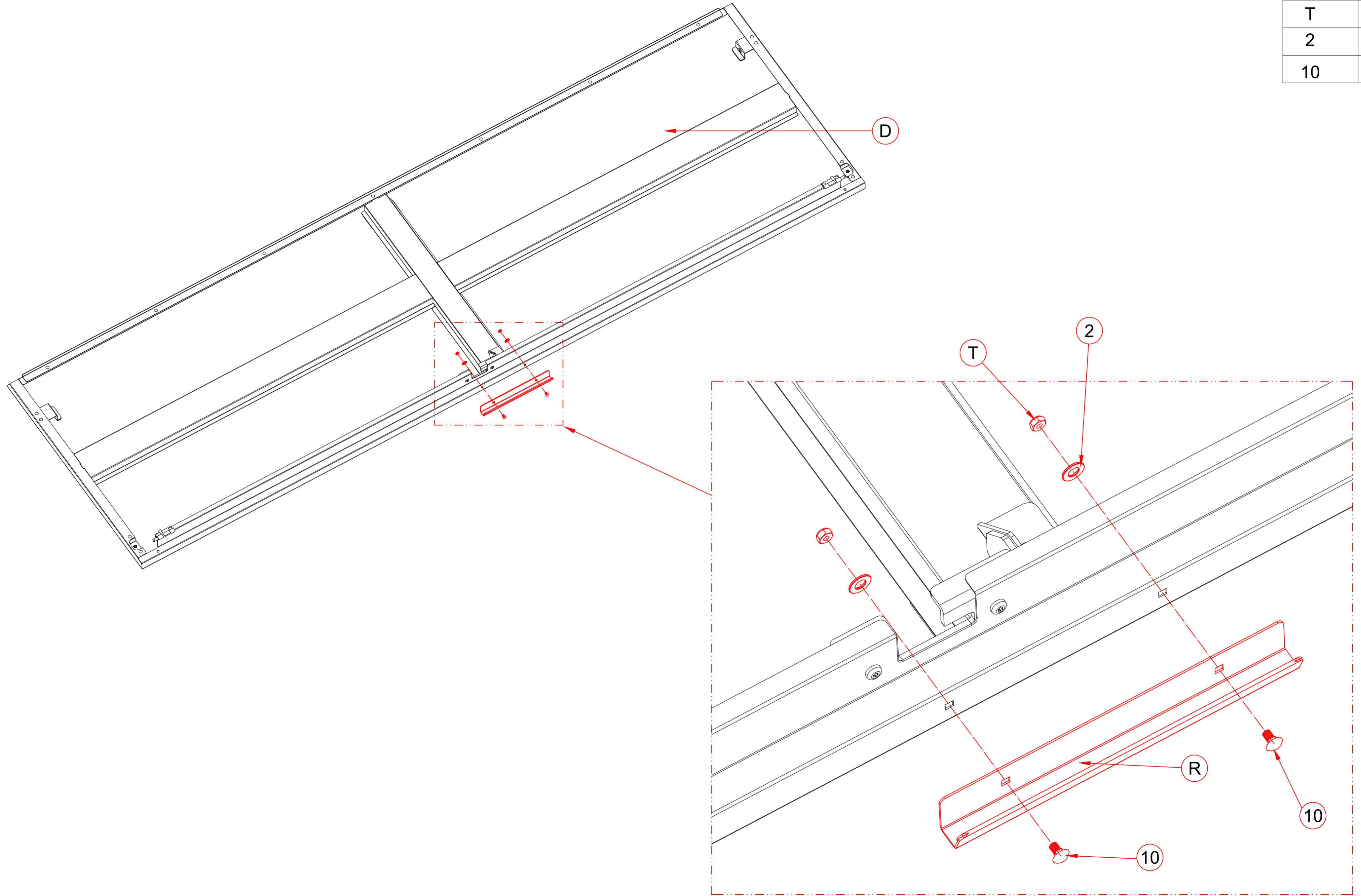

Schritt 18

ITEM	Qty
D	1
X	3
V	9

Geschlossener Zustand

Geöffneter Zustand

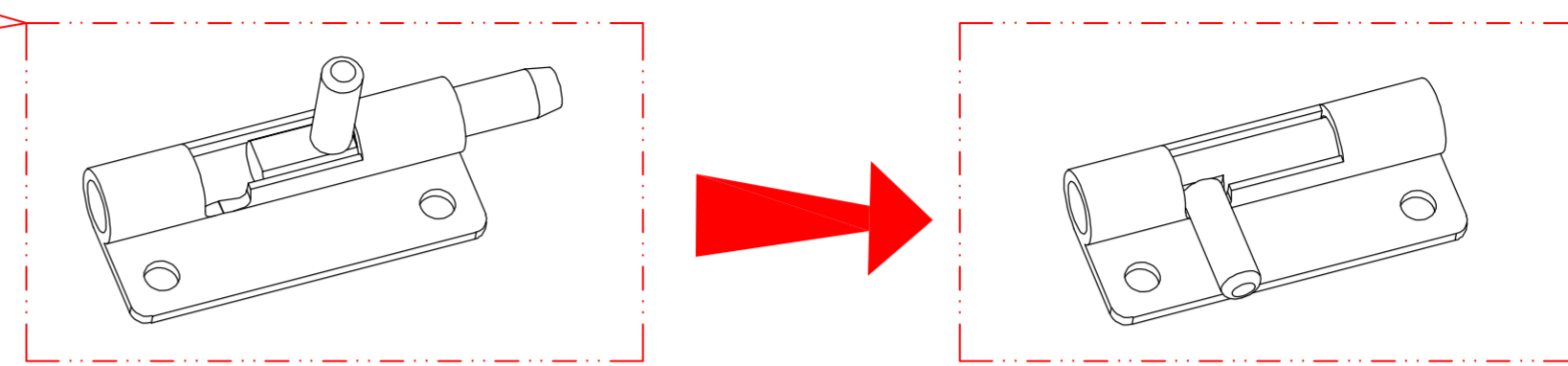

Bitte stellen Sie die Schraube im geöffneten Zustand ein, bevor Sie die obere Abdeckung schließen.

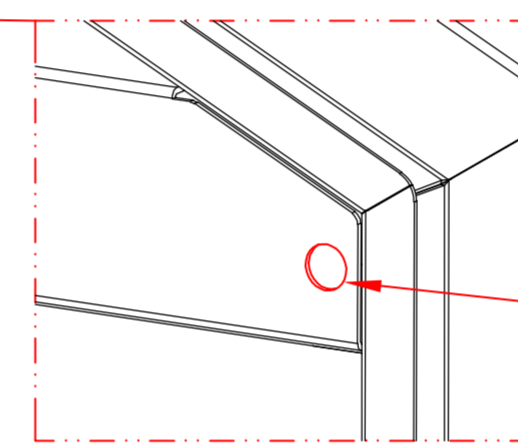

Schlüsselloch

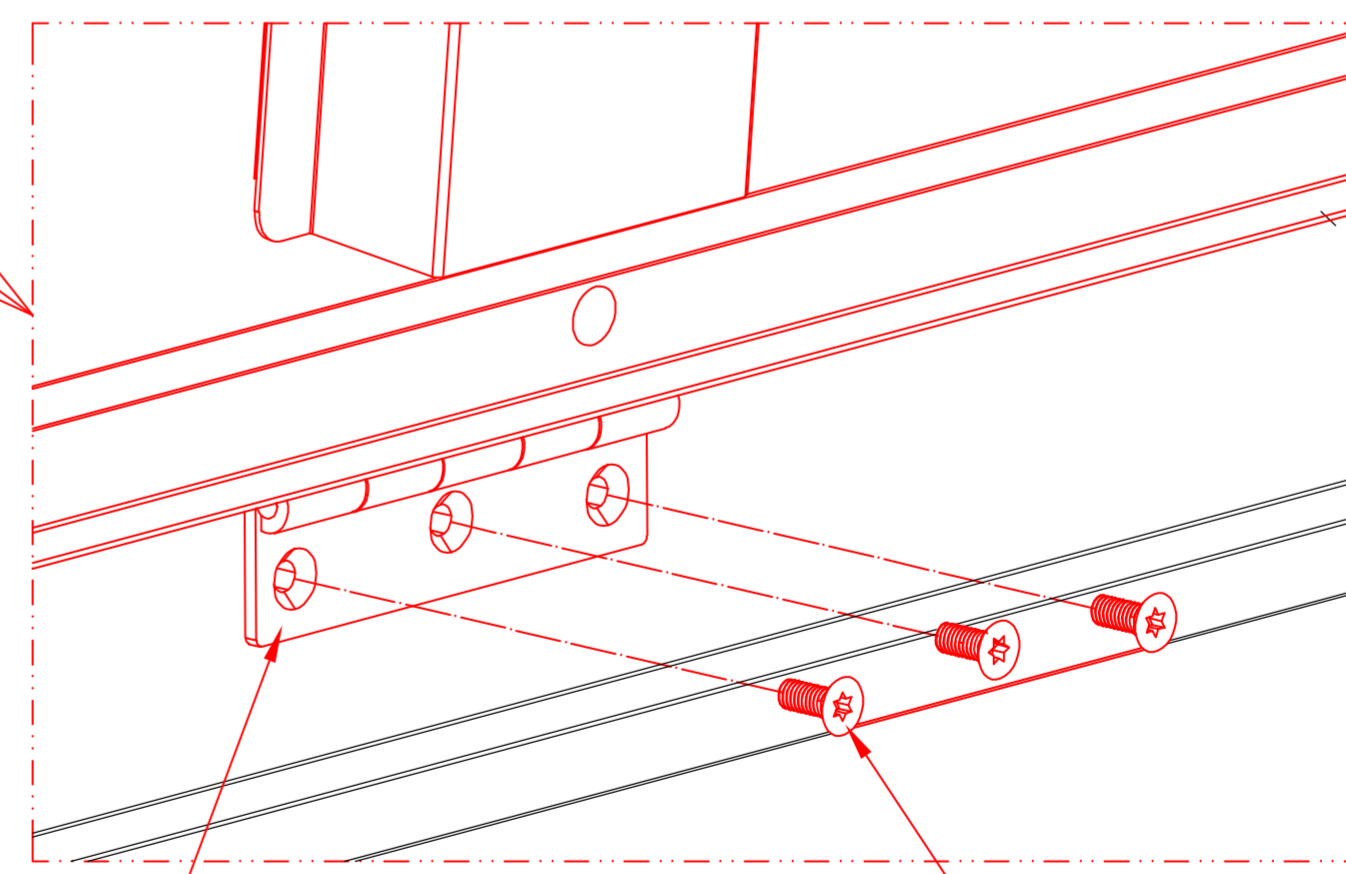

X

V

Schritt19

ITEM	Qty
Z	4
4	2

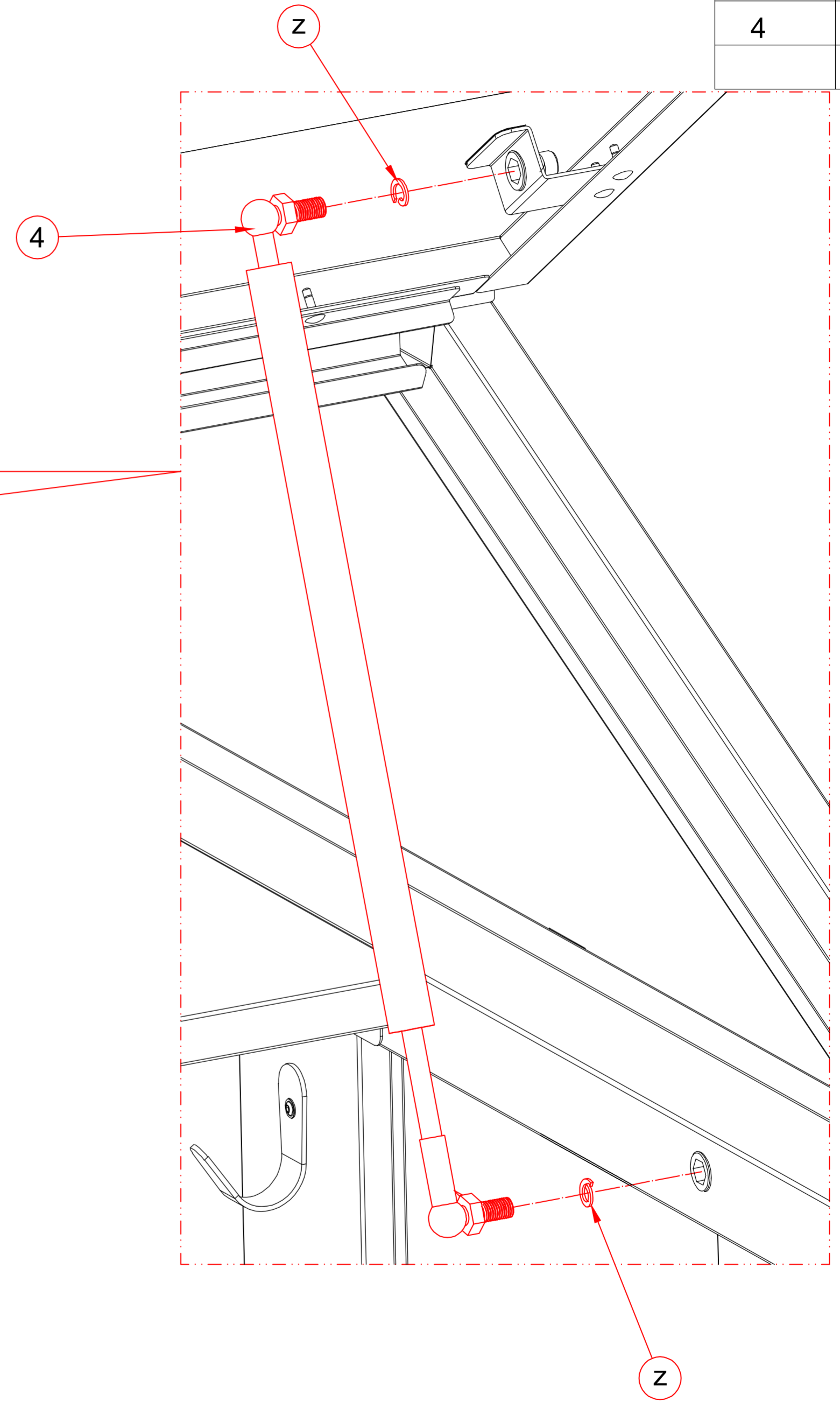
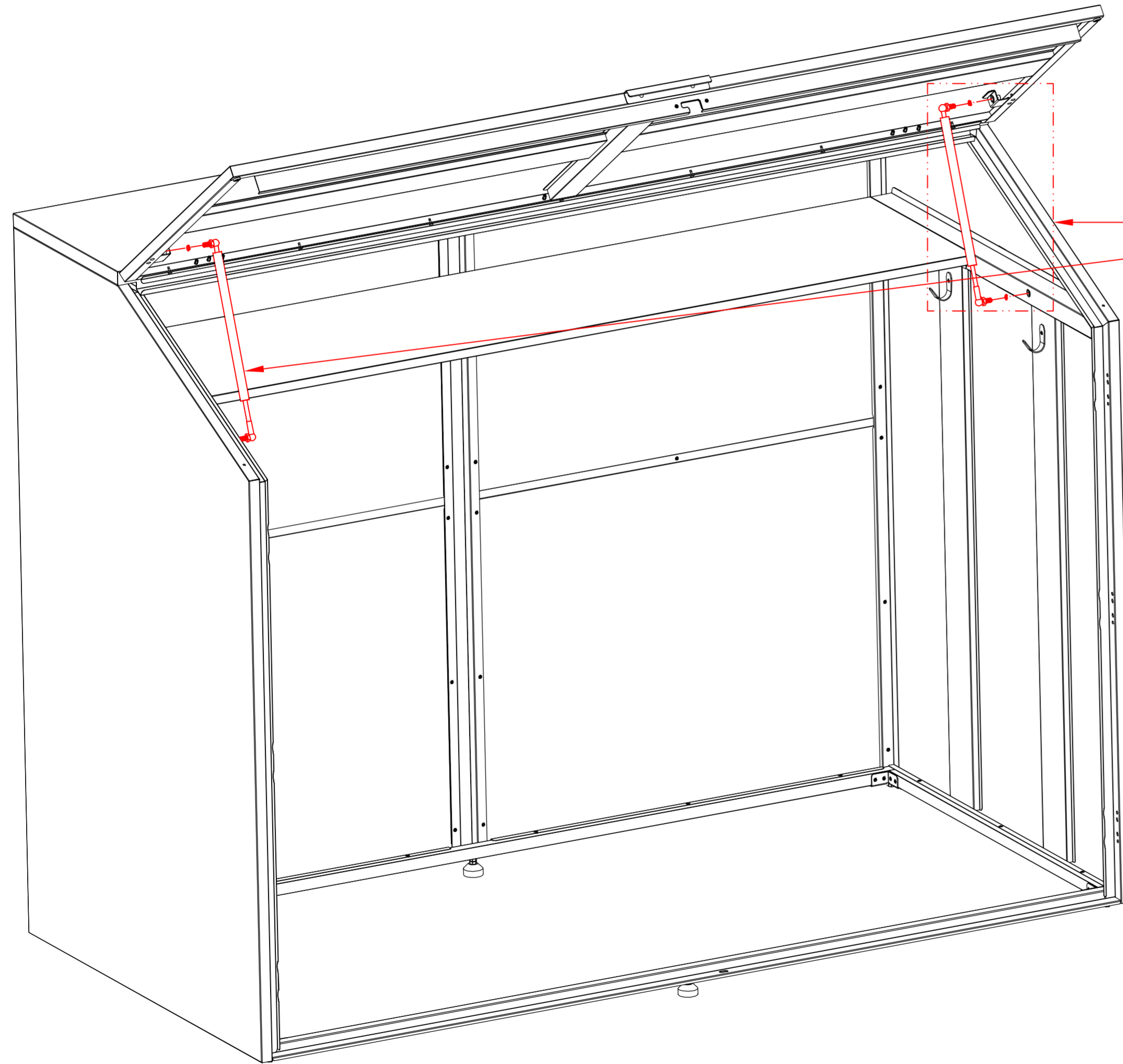

Schritt20

ITEM	Qty
G	1
6	1
S	1
T	2
2	2
3	1
5	1
10	2
11	2

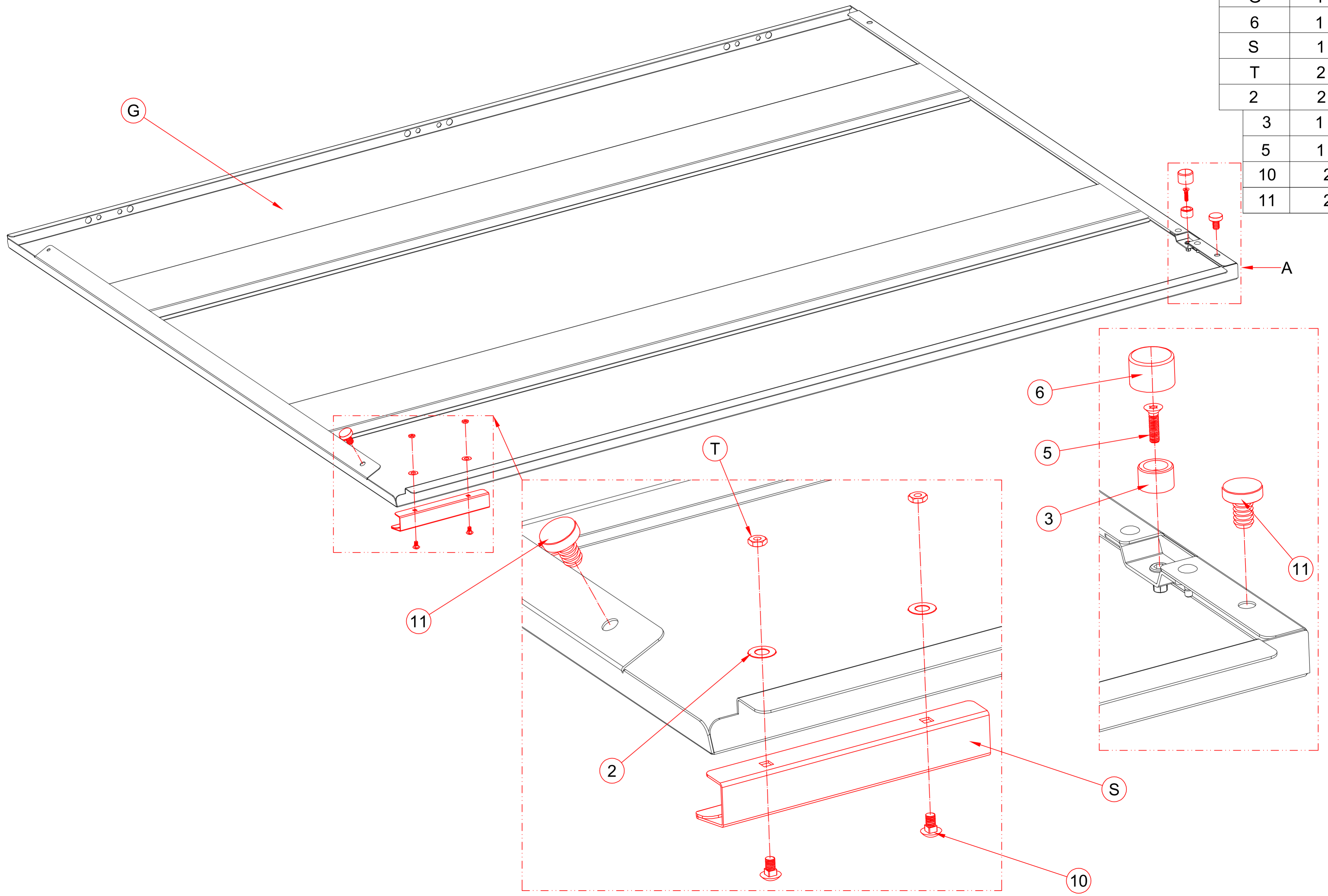

Schritt21

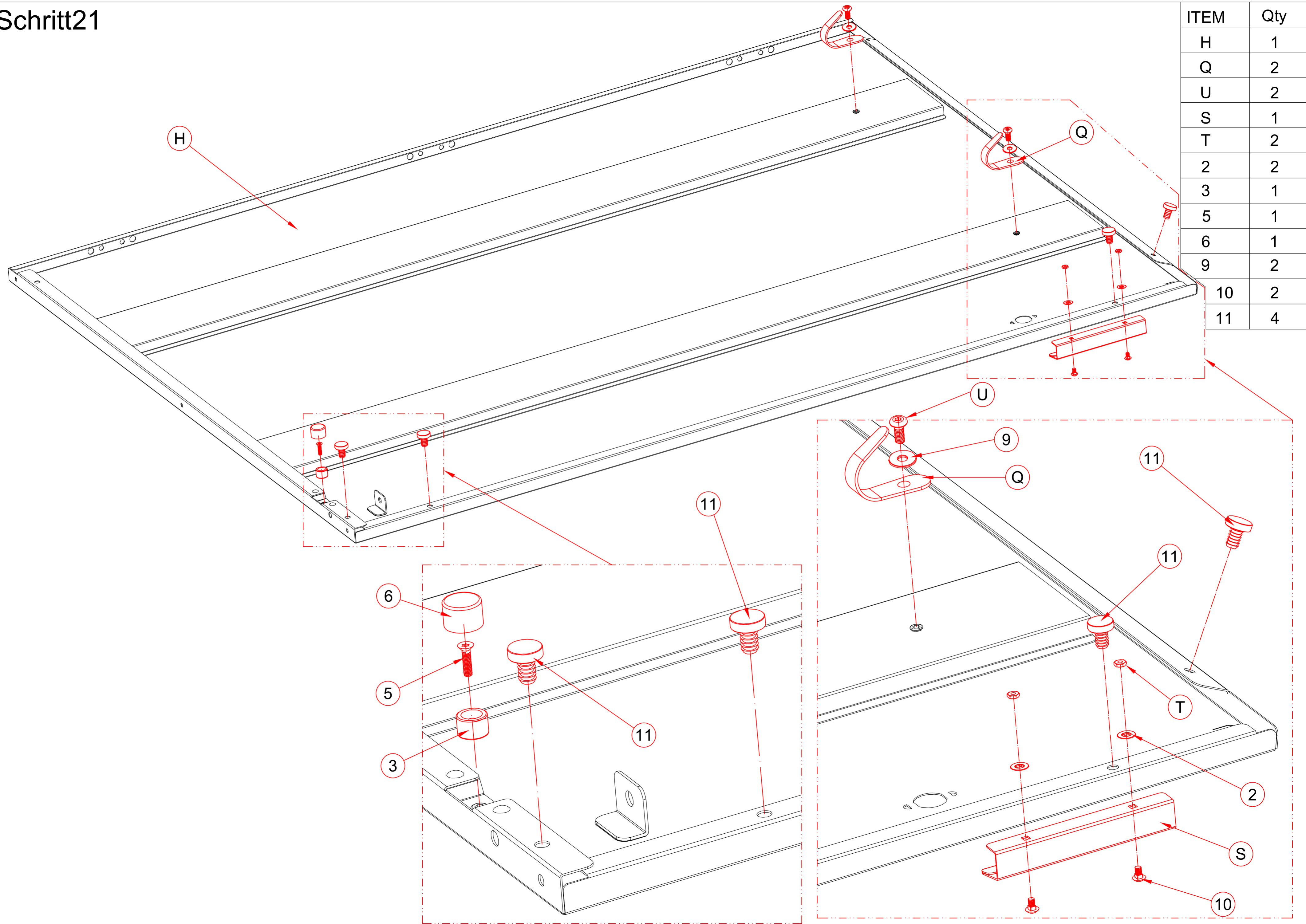

ITEM	Qty
H	1
Q	2
U	2
S	1
T	2
2	2
3	1
5	1
6	1
9	2
10	2
11	4

Schritt22

ITEM	Qty
G	1
H	1
Y	6
V	12

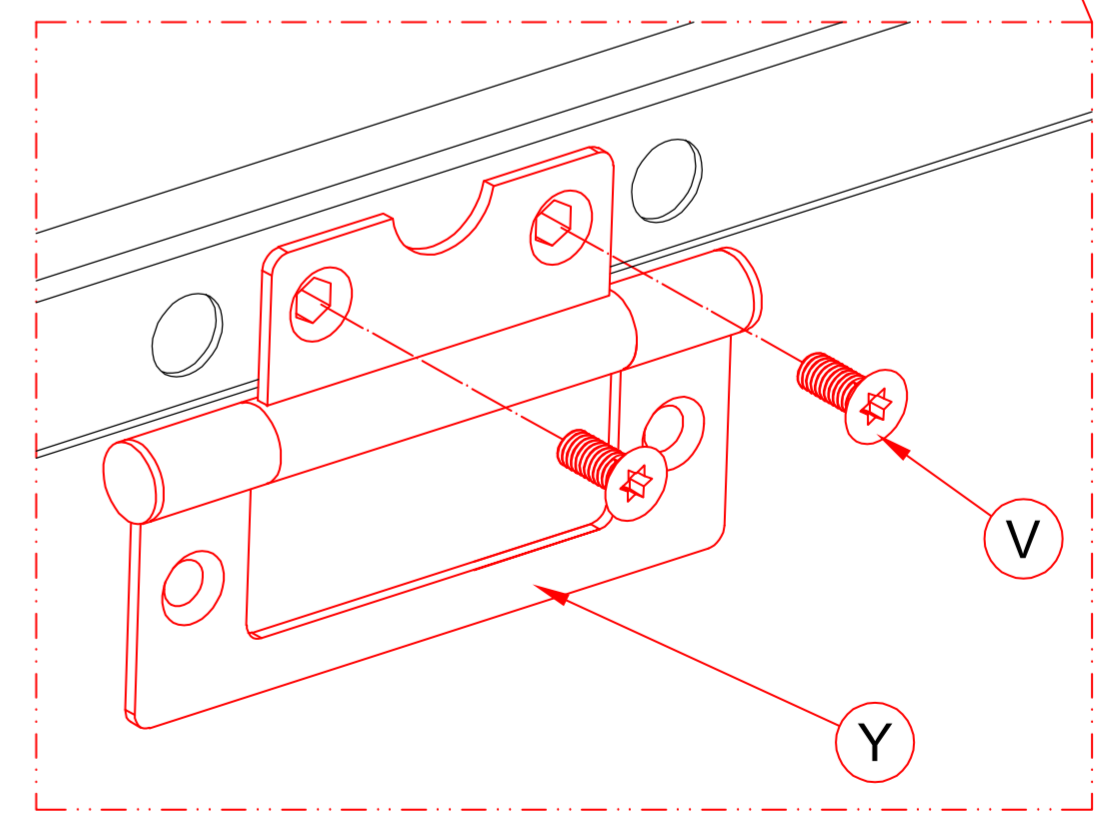
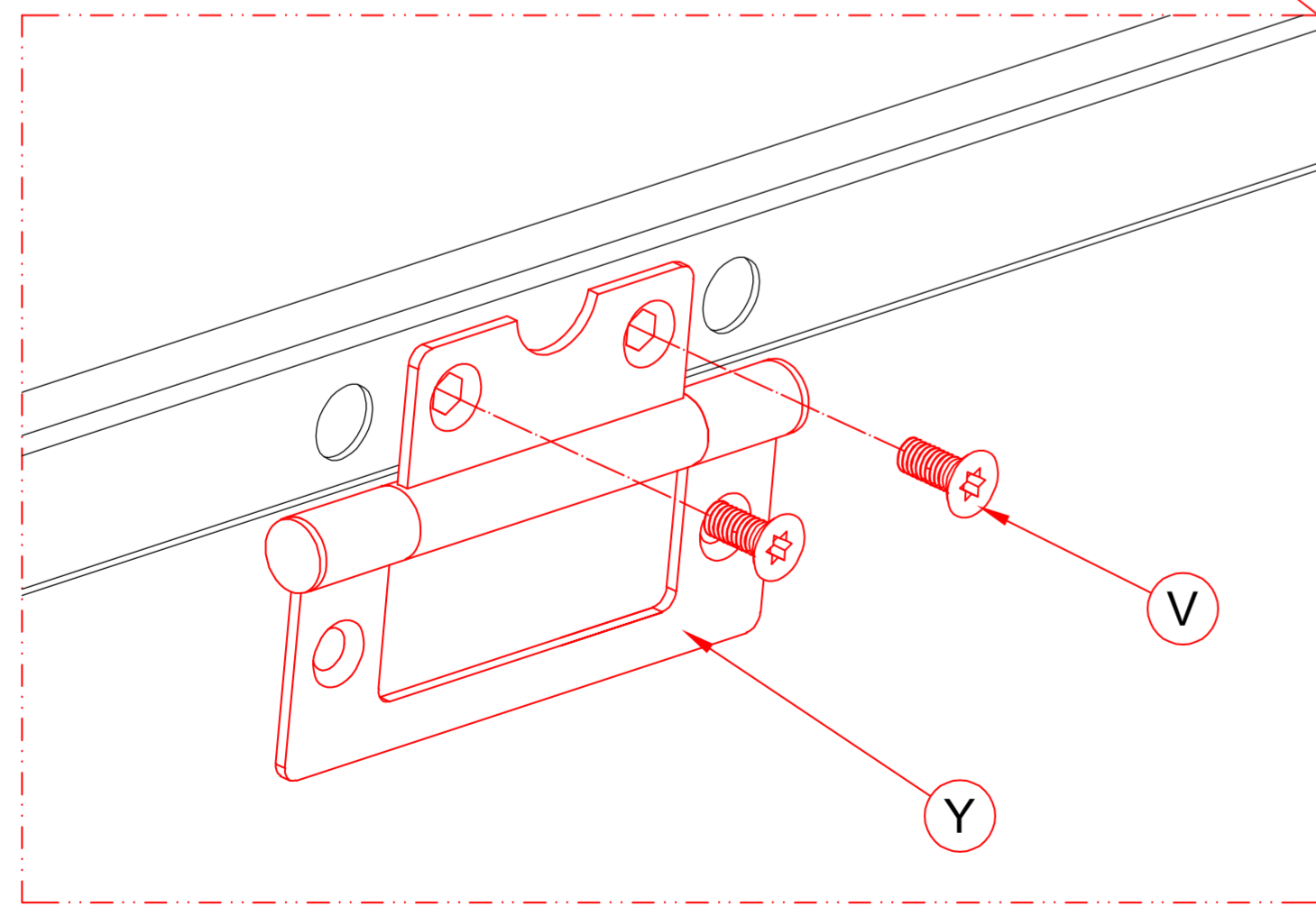
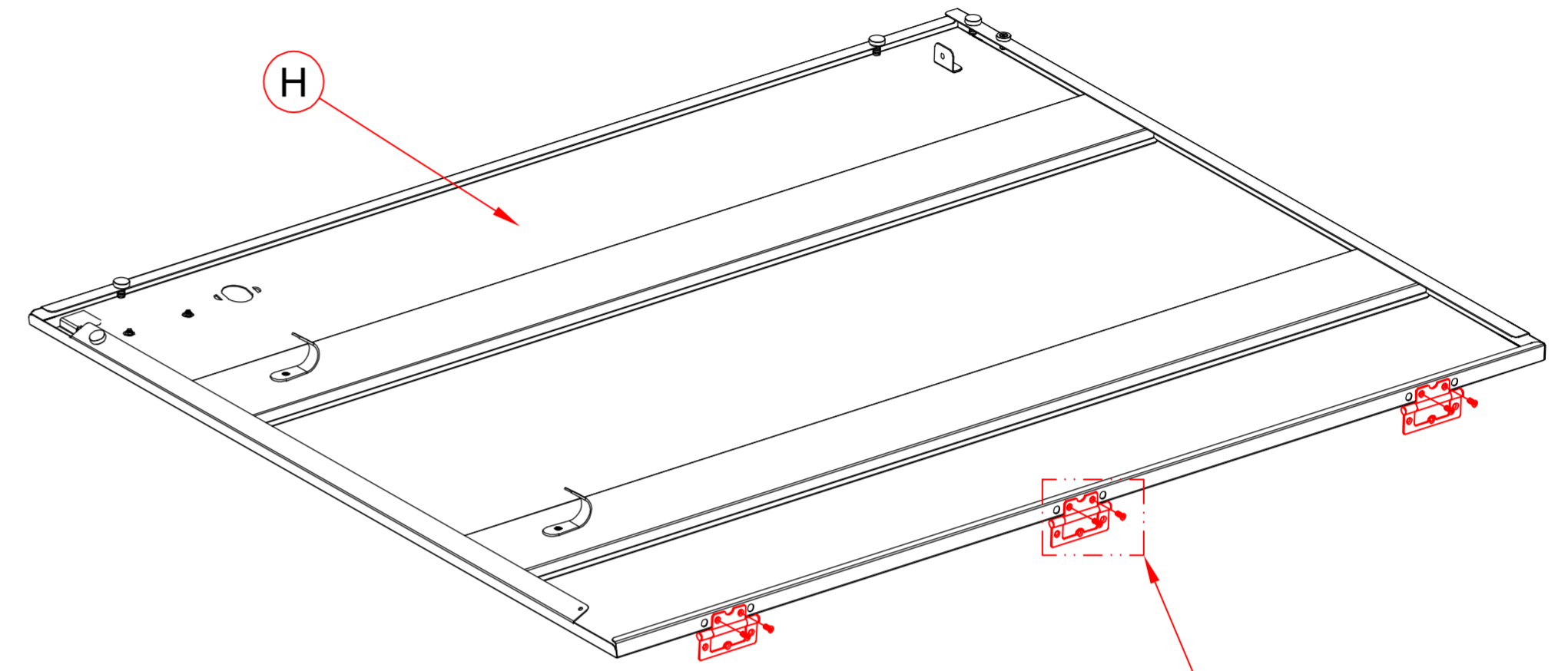
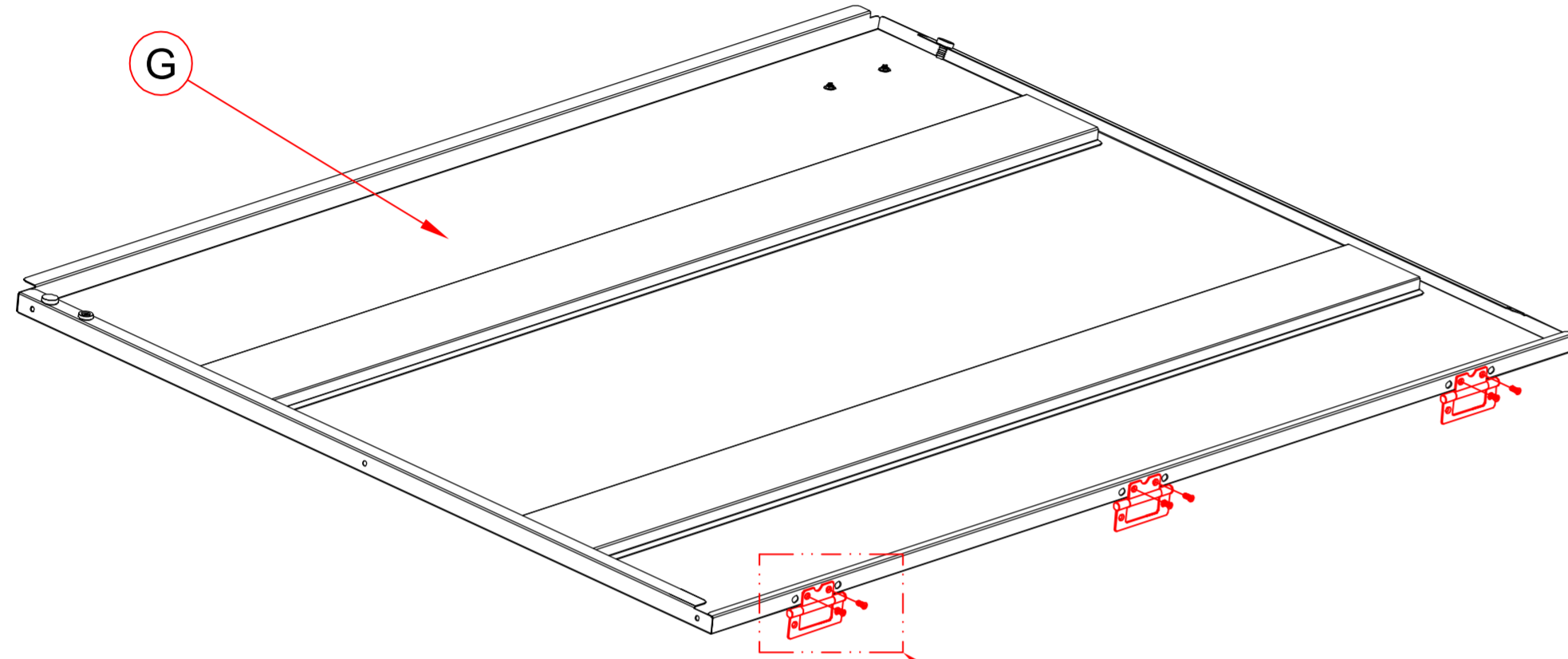

Schritt23

ITEM	Qty
H	1
P	1
1	1
2	1
8	1

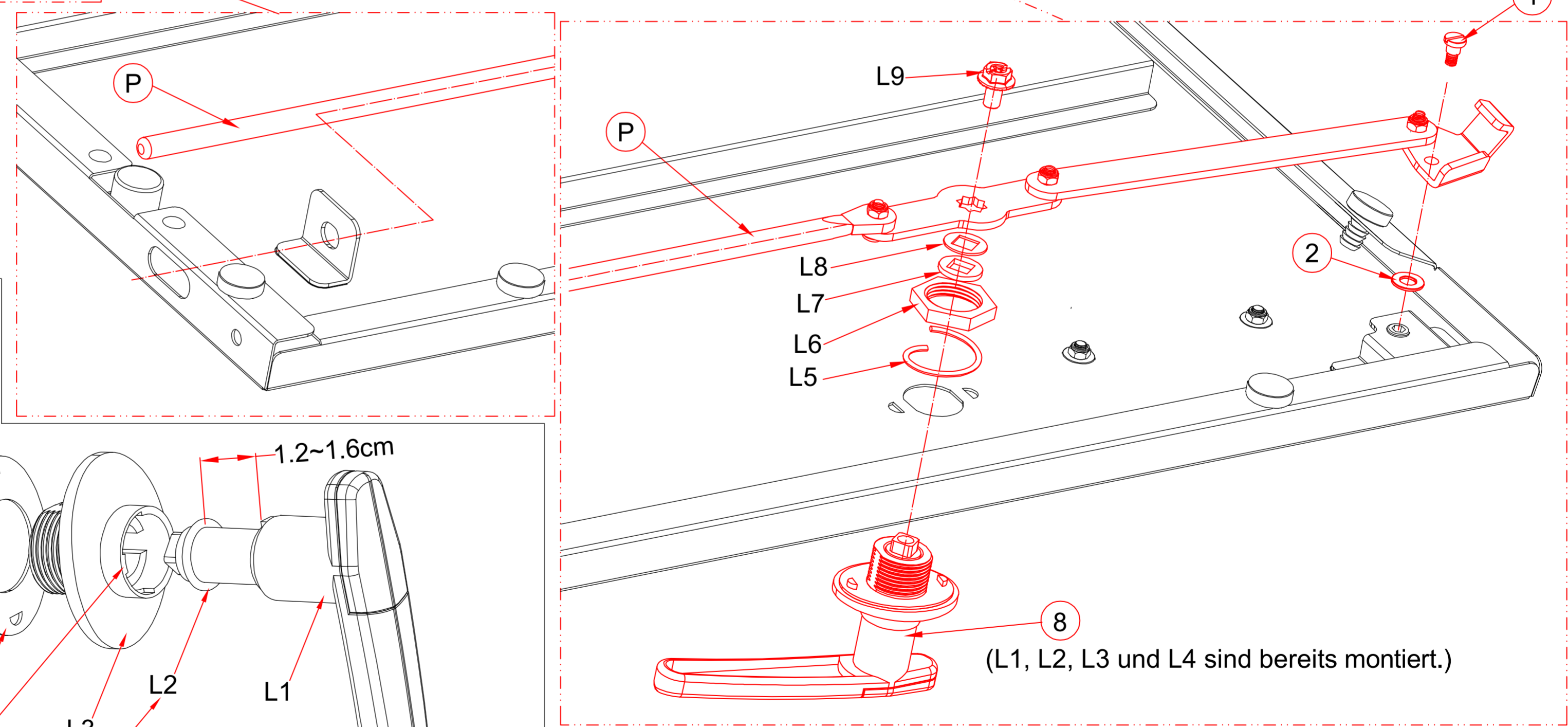
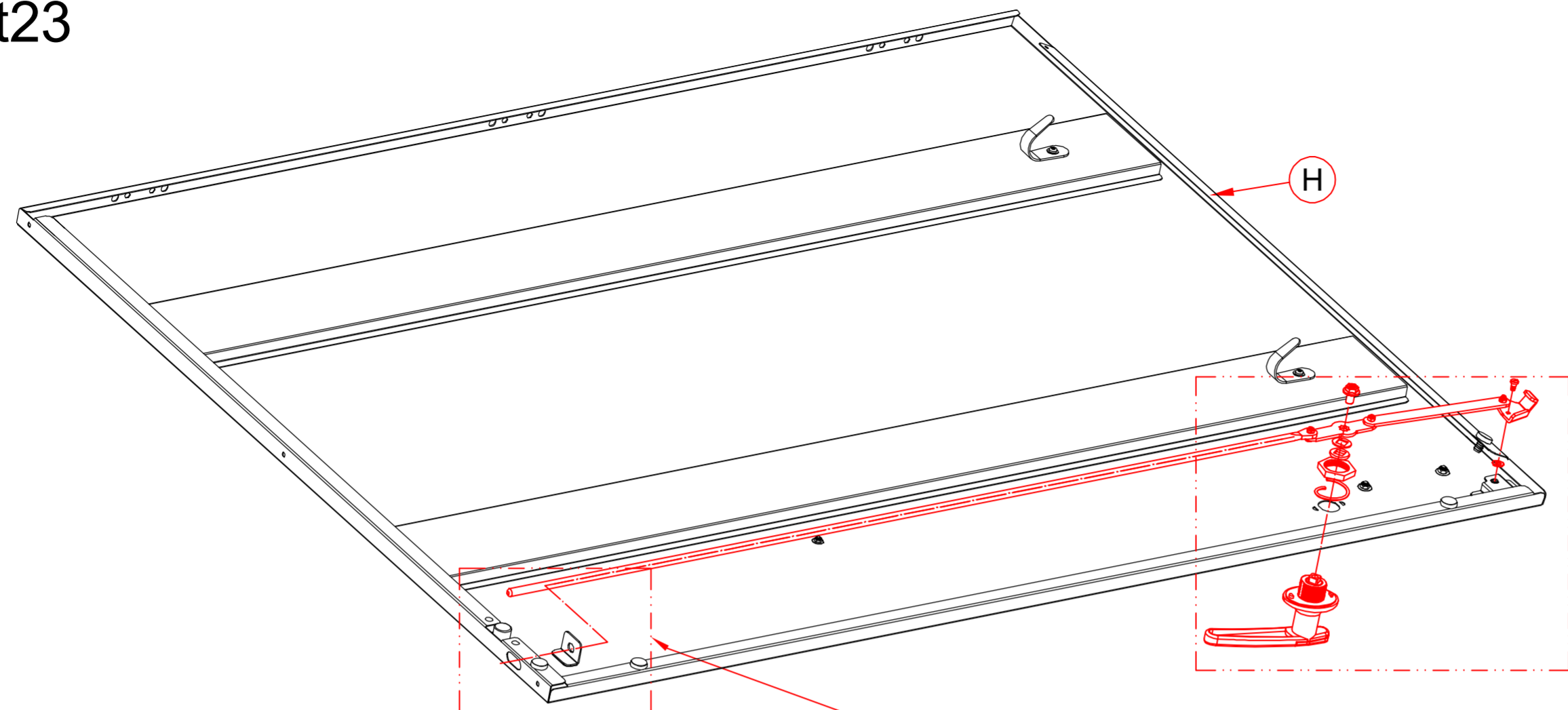

8x1(Detailzeichnung)

Bevor Sie es an der Tür anbringen, montieren Sie bitte zuerst L1, L2, L3 und L4.

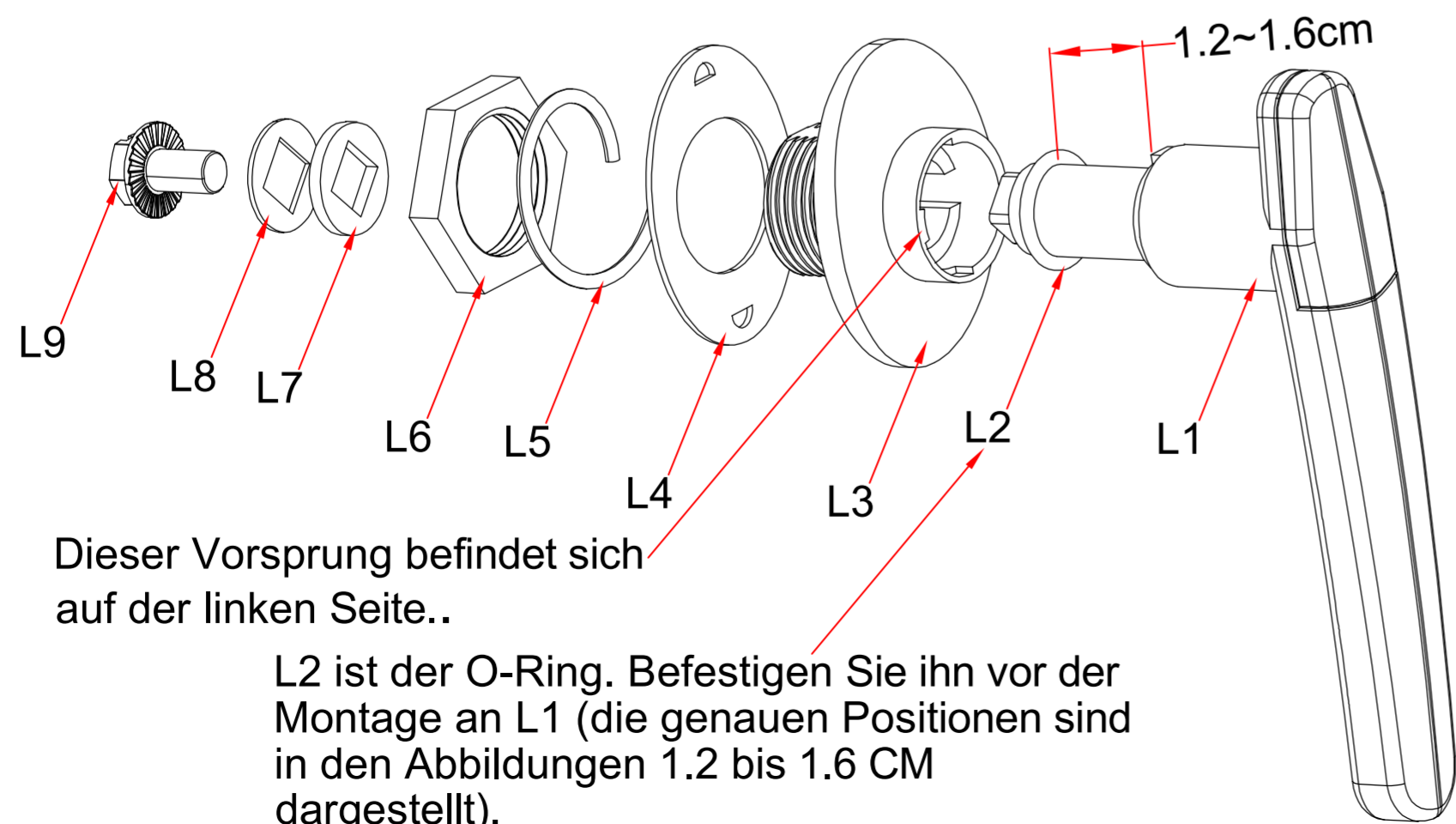

Dieser Vorsprung befindet sich auf der linken Seite..

L2 ist der O-Ring. Befestigen Sie ihn vor der Montage an L1 (die genauen Positionen sind in den Abbildungen 1.2 bis 1.6 CM dargestellt).

(L1, L2, L3 und L4 sind bereits montiert.)

Schritt24

ITEM	Qty
G	1
Y	3
V	6

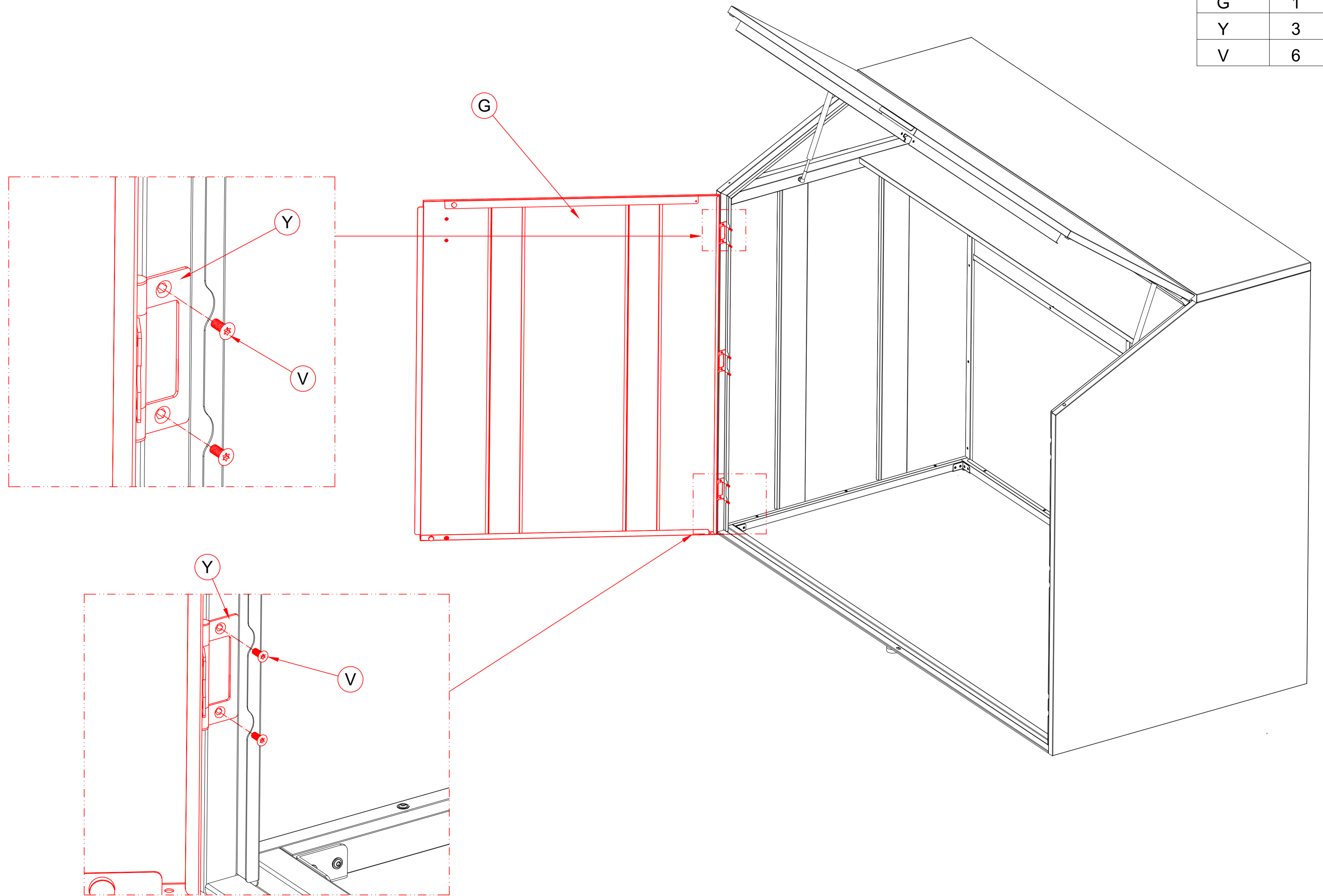

Schritt25

ITEM	Qty
H	1
Y	3
V	6

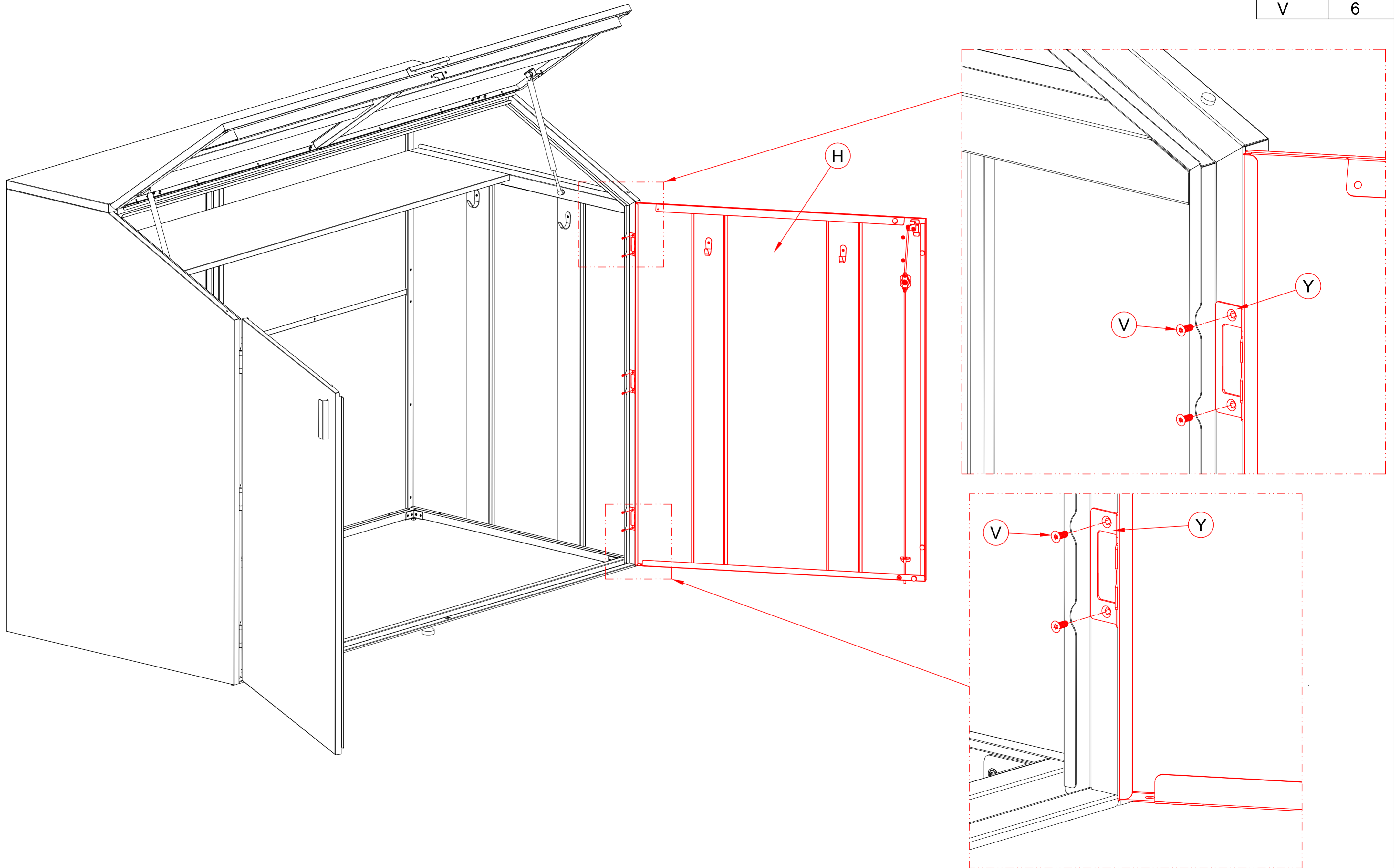

Schritt26

ITEM	Qty
7	2

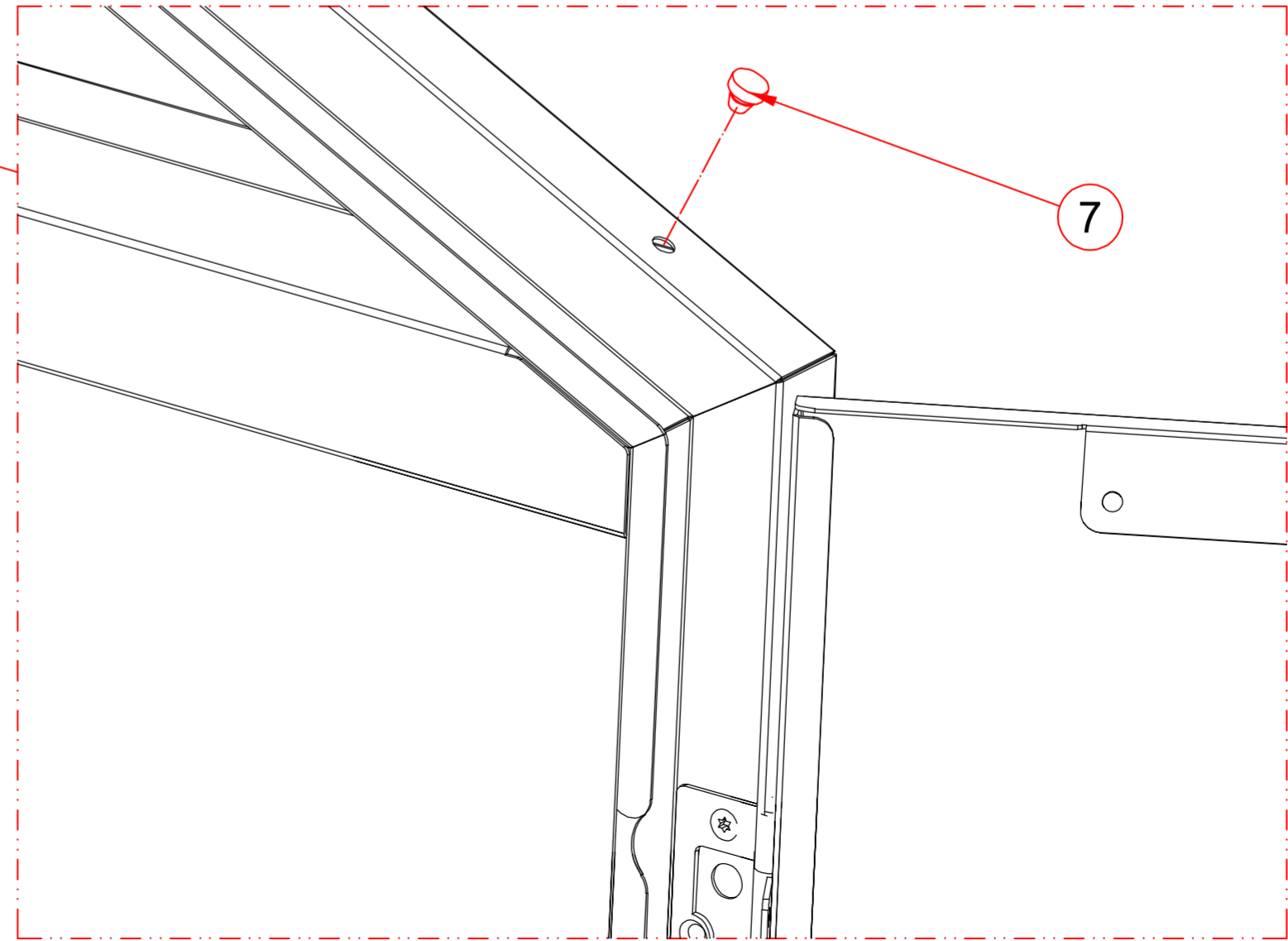
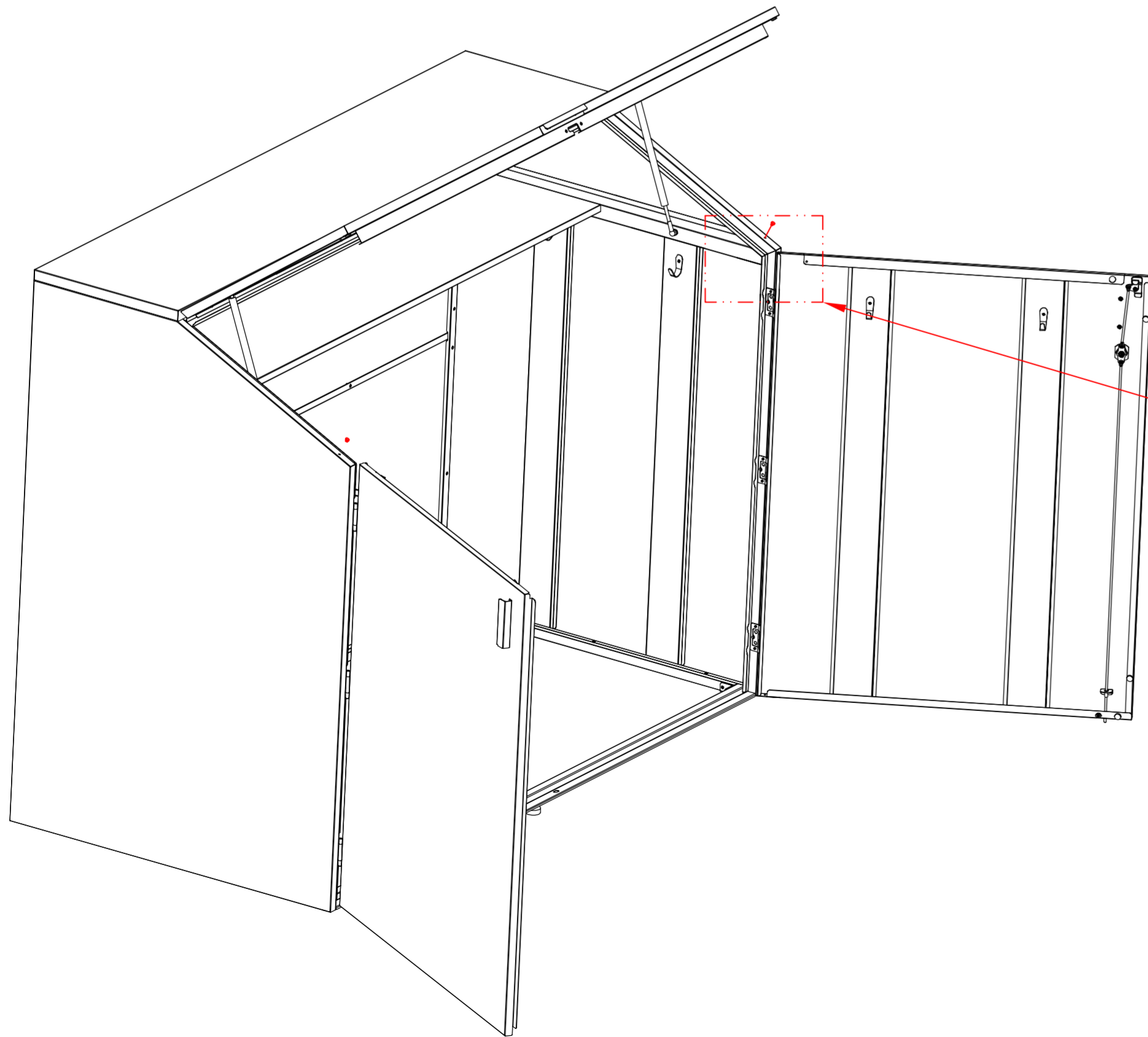
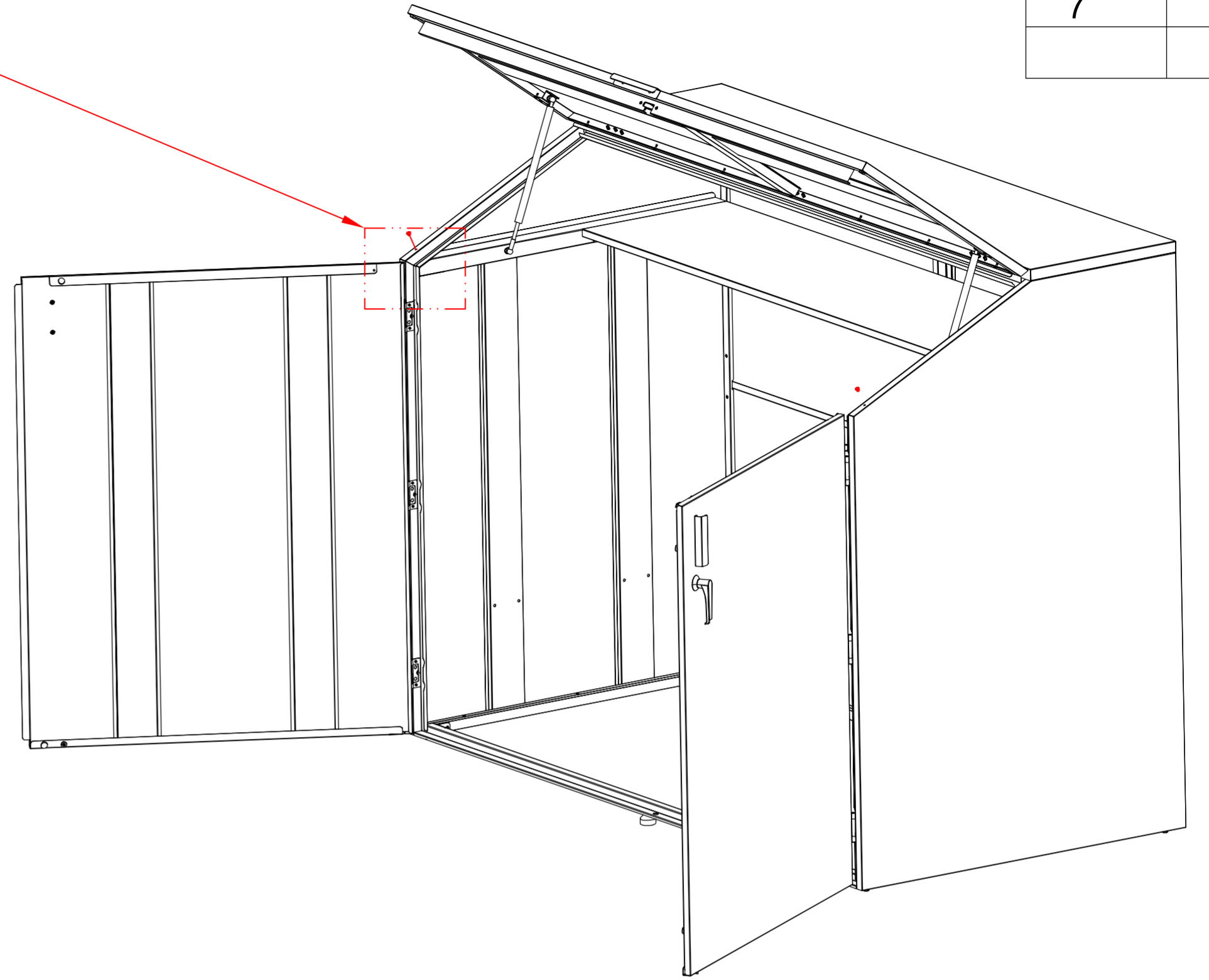
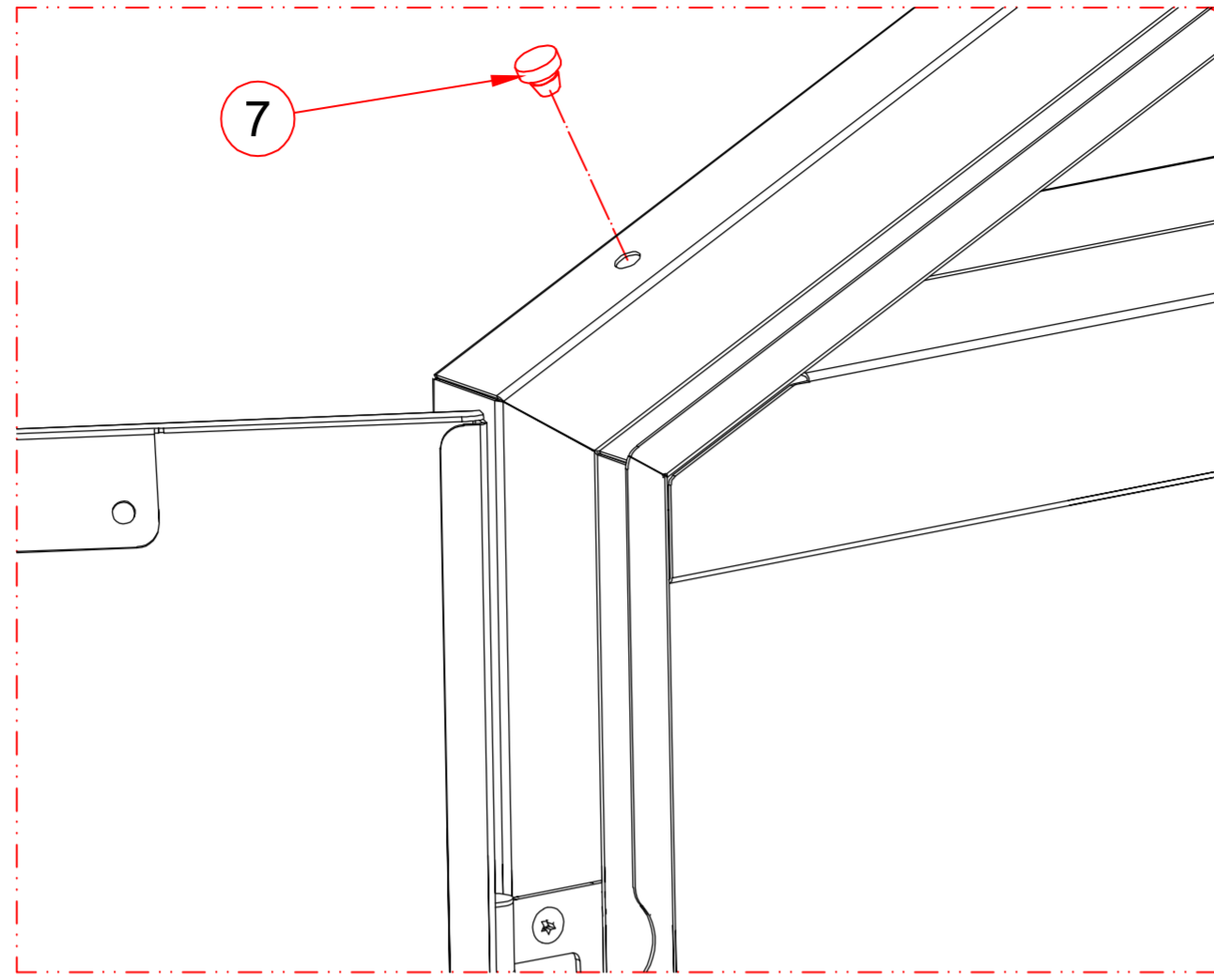

Schritt27

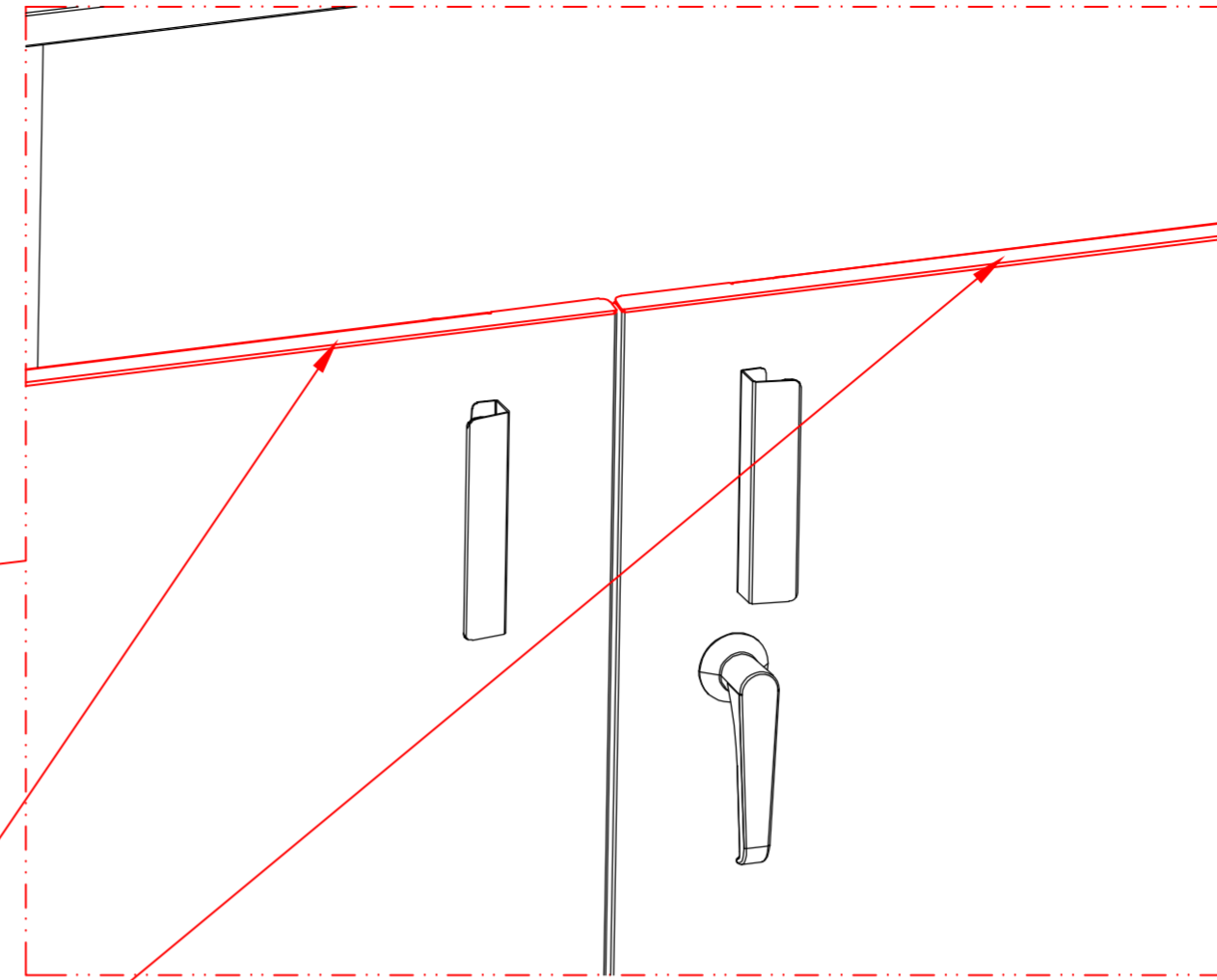
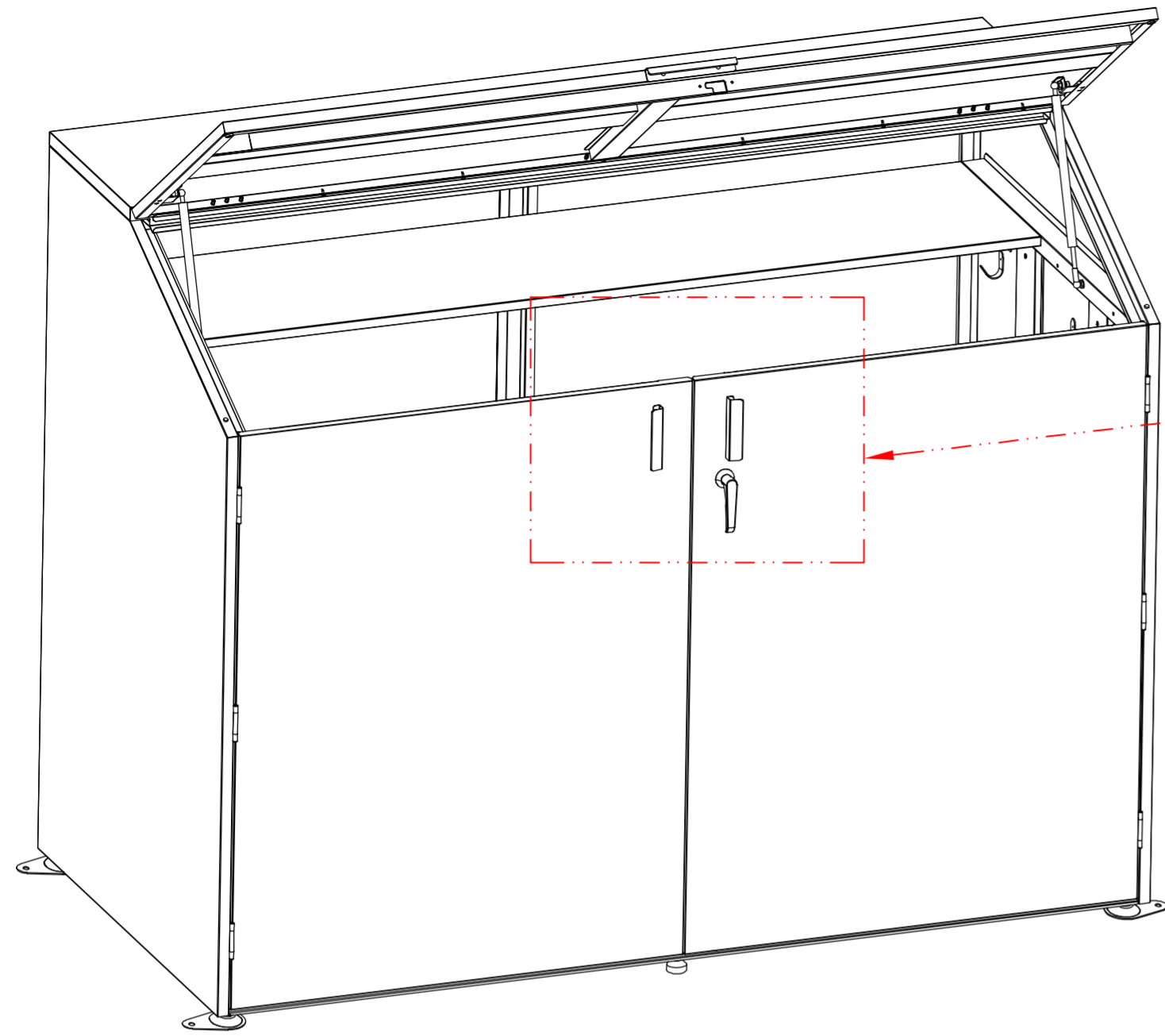

Die Oberkante der Tür muss vollkommen waagrecht sein. Wenn sie nicht parallel ist, justieren Sie vorsichtig die fünf Fußpolster darunter, bis alle Türen reibungslos öffnen und schließen.

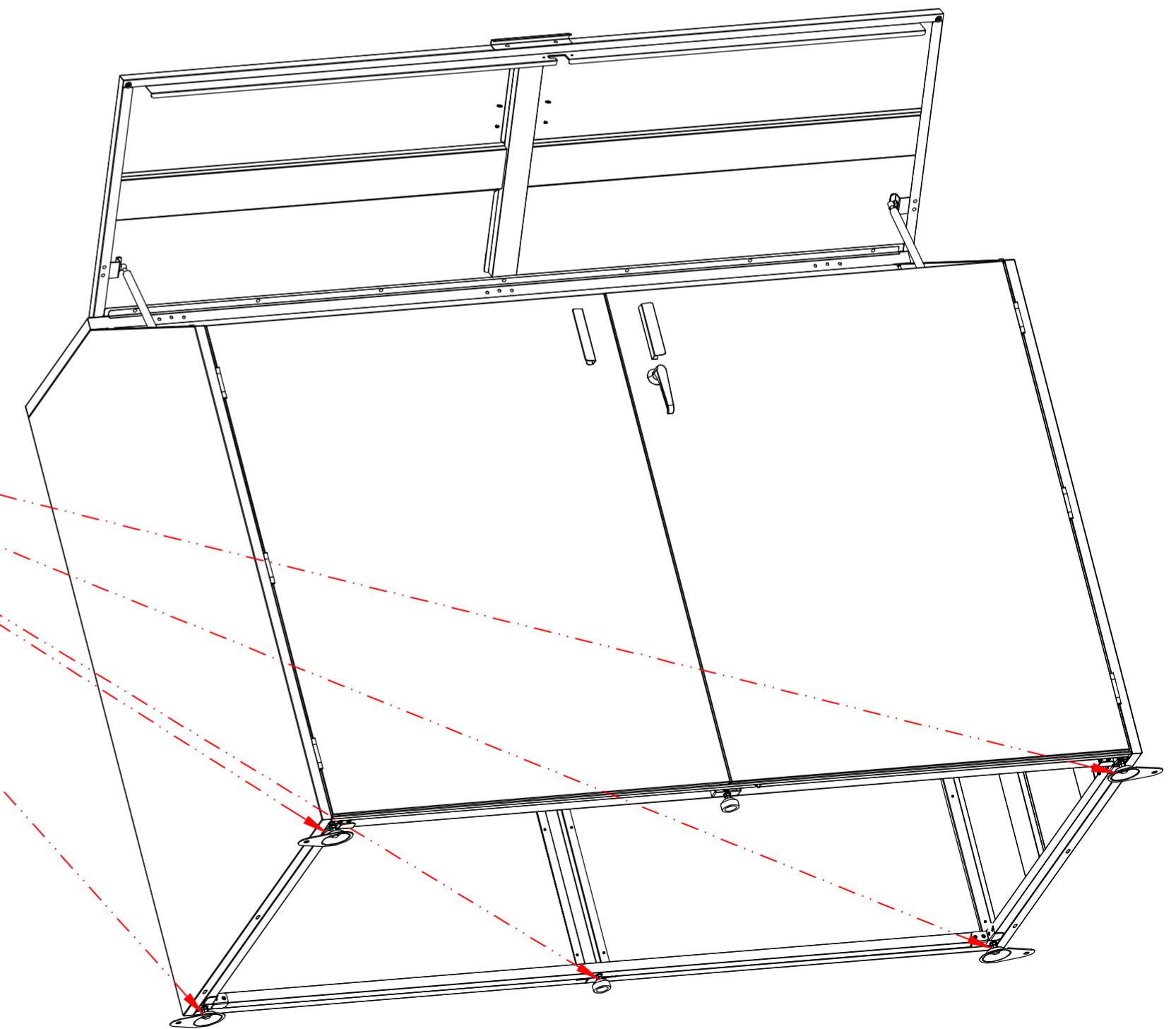
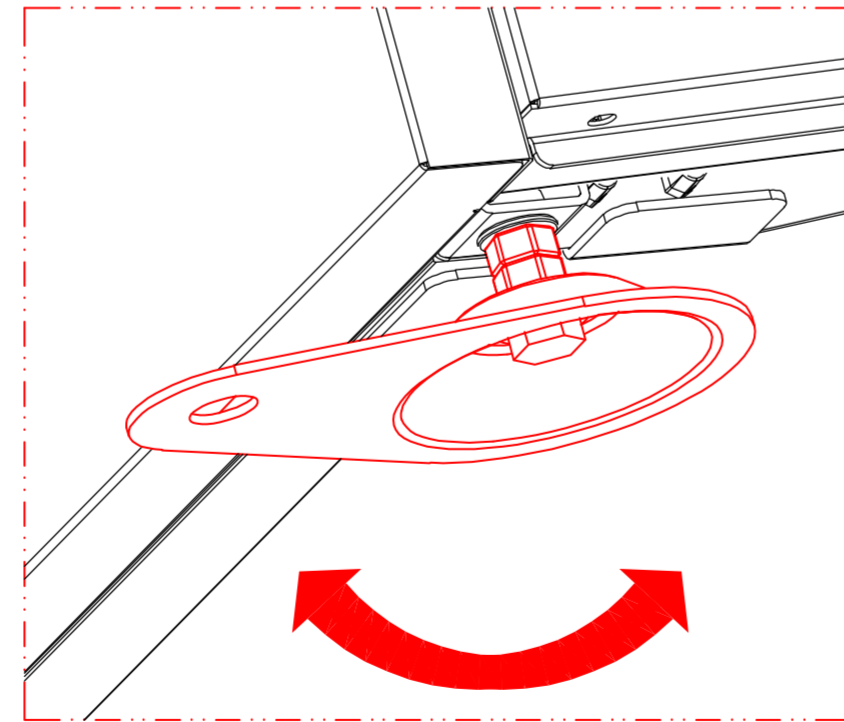
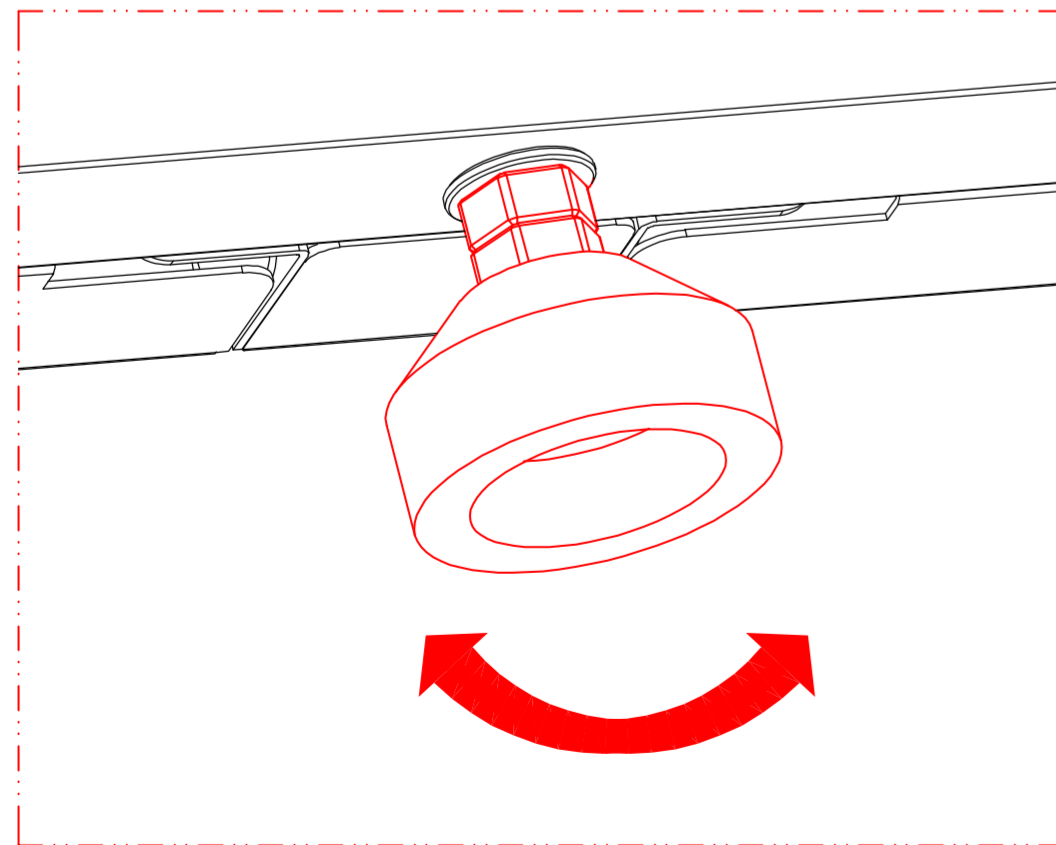

Schritt28

ITEM	Qty
16	4
17	4
18	4

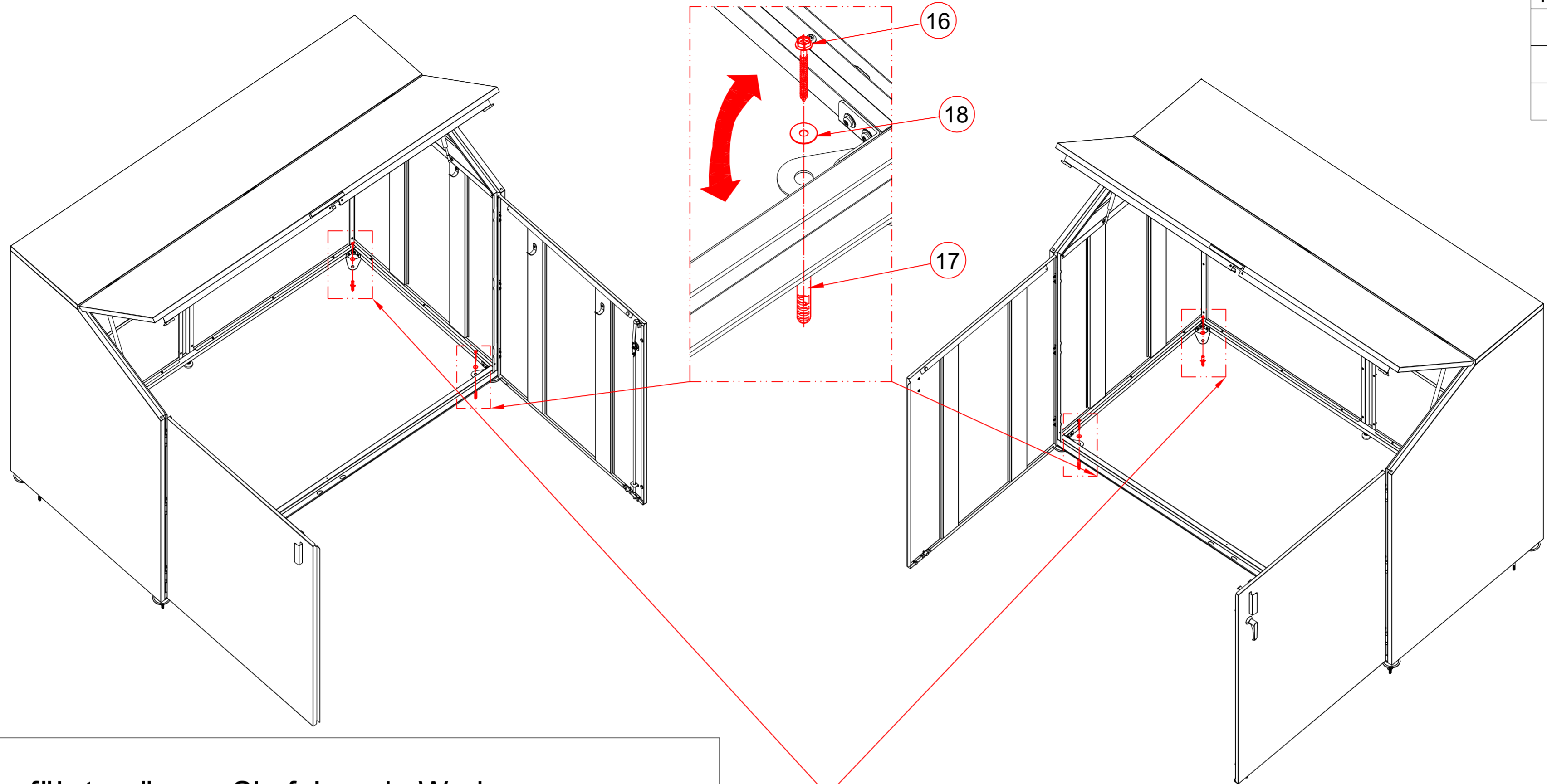

HINWEIS:

Wie unten aufgeführt, müssen Sie folgende Werkzeuge selbst bereitstellen:

- 1, Schlagbohrmaschine;
- 2, Bohrer Ø8,0 mm;
- 3, Kreuzschlitz-Elektroschrauber.

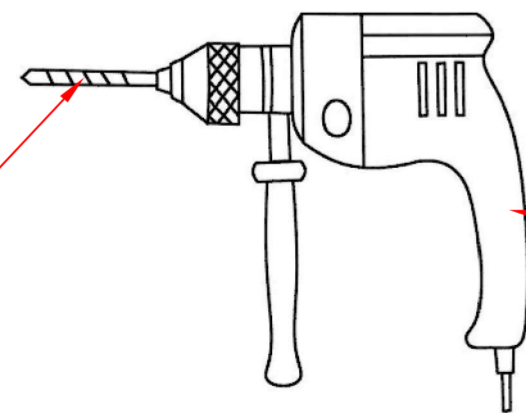

Bohrer Ø8,0 mm

Kreuzschlitz-Elektroschrauber

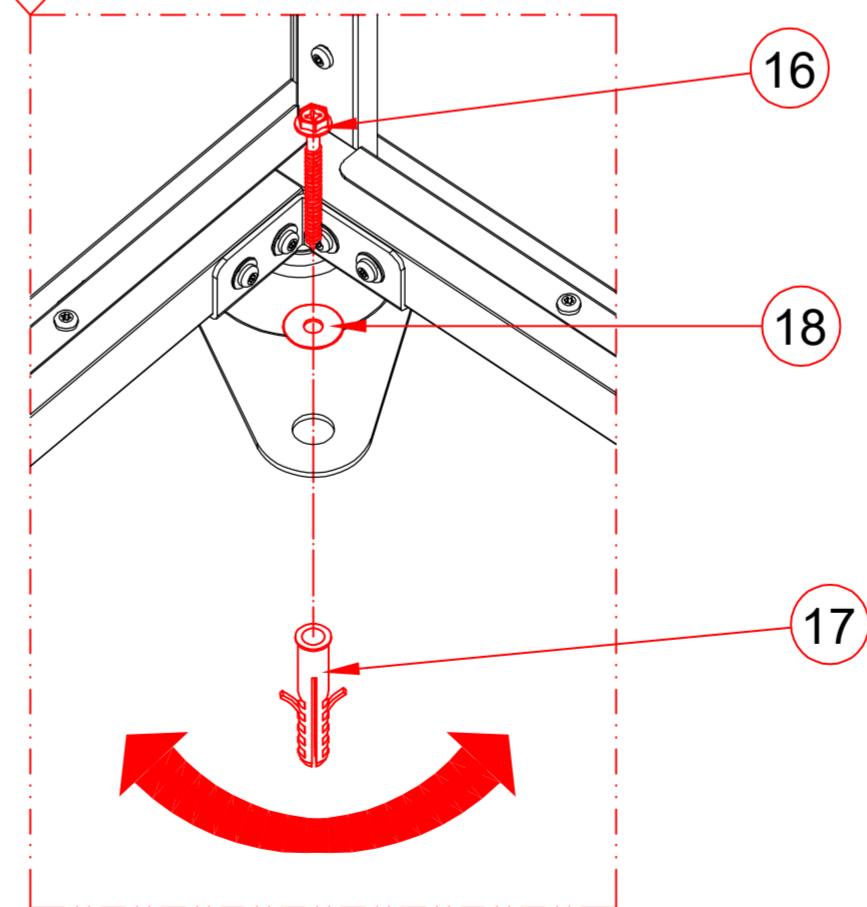
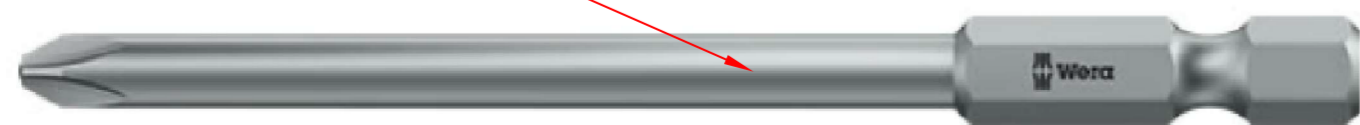

Schritt29

ITEM	Qty
20	1
21	1
22	1

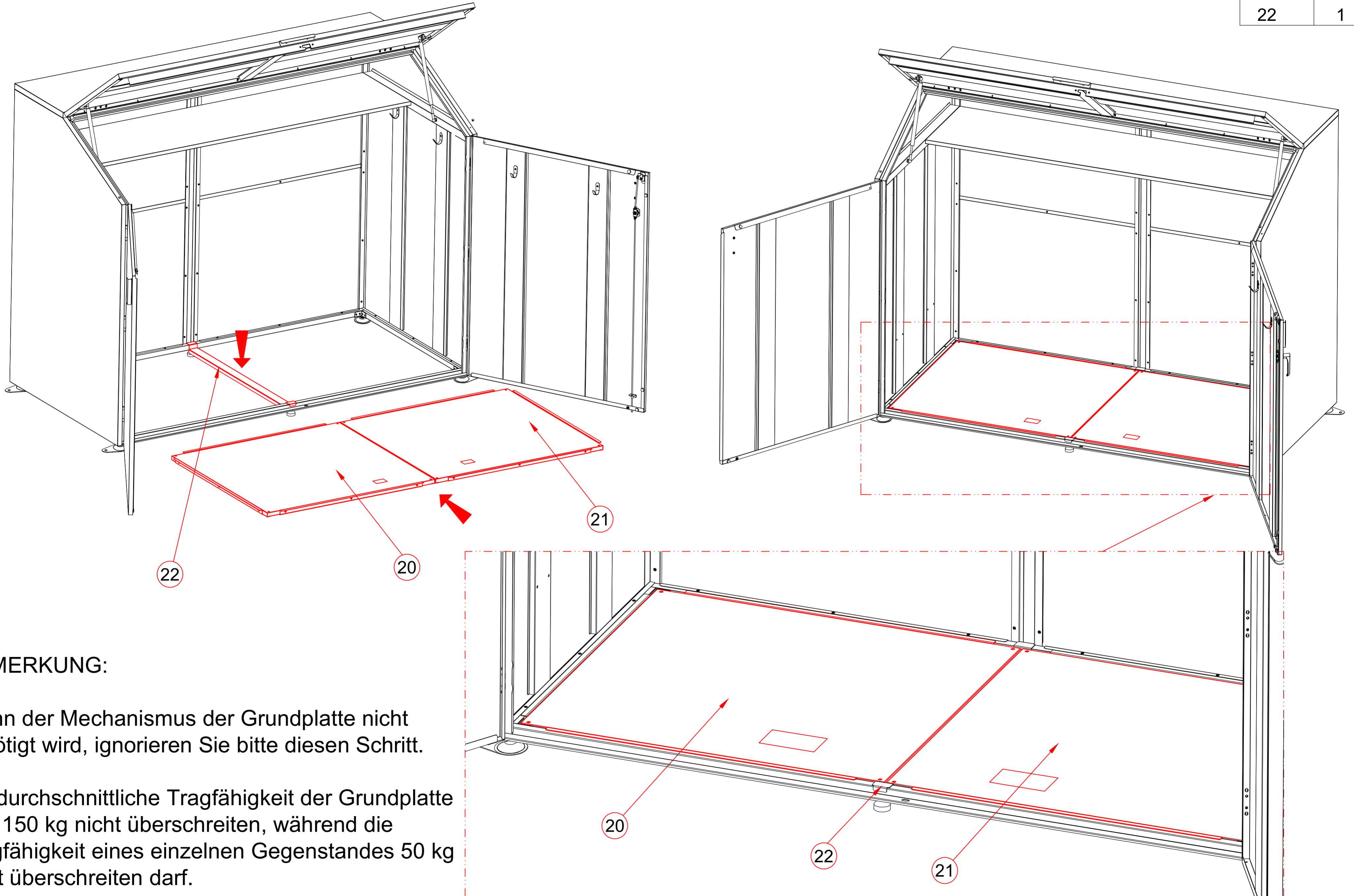

ANMERKUNG:

1:
Wenn der Mechanismus der Grundplatte nicht benötigt wird, ignorieren Sie bitte diesen Schritt.

2:
Die durchschnittliche Tragfähigkeit der Grundplatte darf 150 kg nicht überschreiten, während die Tragfähigkeit eines einzelnen Gegenstandes 50 kg nicht überschreiten darf.